

ED 022 927

08

VT 006 874

By-Dobrovolsky, Jerry S.; And Others

HOROLOGICAL AND MICRO-PRECISION PROJECT. FINAL REPORT.

Illinois Univ., Urbana.

Spons Agency-Office of Education (DHEW), Washington, D.C.

Bureau No-BR-6-2336

Pub Date Jan 68

Grant-OEG-4-6-062336-2081

Note-260p.

EDRS Price MF-\$1.00 HC-\$10.48

Descriptors-COURSE CONTENT, CURRICULUM, *CURRICULUM DEVELOPMENT, CURRICULUM GUIDES, *DEMONSTRATION PROJECTS, *HOROLOGY, INSTRUCTIONAL MATERIALS, PILOT PROJECTS, PROGRAM DEVELOPMENT, PROGRAMED INSTRUCTION, PROGRAMED MATERIALS, TEACHING METHODS, *TECHNICAL EDUCATION, *WATCHMAKERS

Identifiers-Micro Precision Technology

The purposes of the project were (1) to establish better methods of training technicians for the horological and industrial fields, (2) to encourage more young people to investigate horological and micro-precision work as a career, (3) to train a group of students who would be employable in diverse horological and industrial areas, and (4) to help horological schools in their training programs through the benefits of this research and demonstration project. The first period of 5 months was spent in curriculum planning, preparation of class materials, and in equipping the horology laboratory, while the second period of 7 months was used to train a group of students in horological and micro-precision skills. Essentials of preparing and conducting a course in horology and micro-precision technology and a chronological record of the horological and micro-precision laboratory sessions are given to provide information on this first attempt to formulate a course in horology and micro-precision training. Some of the materials generated from the project include (1) course outlines for horology laboratory and related subjects, (2) a proposed certificate horological curriculum and an associate degree micro-precision curriculum, (3) a disassembly and assembly procedure programed instruction booklet, (4) a detached lever escapement function and adjustment booklet, and (5) chronograph illustrations. (HC)

BR-6-2336^{cl}
PA-08

FINAL REPORT

Project No. 6-2336
Grant No. OEG 4-6-062336-2081

PA 08

HOROLOGICAL AND MICRO-PRECISION PROJECT

January, 1968

U.S. DEPARTMENT OF
HEALTH, EDUCATION, AND WELFARE

Office of Education
Bureau of Research

VT006874

ED022927

FINAL REPORT

**Project No. 6-2336
Grant No. OEG 4-6-062336-2081**

**U.S. DEPARTMENT OF HEALTH, EDUCATION & WELFARE
OFFICE OF EDUCATION**

**THIS DOCUMENT HAS BEEN REPRODUCED EXACTLY AS RECEIVED FROM THE
PERSON OR ORGANIZATION ORIGINATING IT. POINTS OF VIEW OR OPINIONS
STATED DO NOT NECESSARILY REPRESENT OFFICIAL OFFICE OF EDUCATION
POSITION OR POLICY.**

HOROLOGICAL AND MICRO-PRECISION PROJECT

January, 1968

**U.S. DEPARTMENT OF
HEALTH, EDUCATION, AND WELFARE**

**Office of Education
Bureau of Research**

FINAL REPORT

Project No. 6-2336
Grant No. OEG 4-6-062336-2081

HOROLOGICAL AND MICRO-PRECISION PROJECT

Jerry S. Dobrovolny, Director
Hugh G. Wales, Supervisor
William O. Smith, Jr., Research Associate

University of Illinois
Urbana, Illinois

January, 1968

The research reported herein was performed pursuant to a grant with the Office of Education, U.S. Department of Health, Education, and Welfare. Contractors undertaking such projects under Government sponsorship are encouraged to express freely their professional judgment in the conduct of the project. Points of view or opinions stated do not, therefore, necessarily represent official Office of Education position or policy.

U.S. DEPARTMENT OF
HEALTH, EDUCATION, AND WELFARE

Office of Education
Bureau of Research

FOREWORD

For the past two decades there has been a steady decline in the number of horological schools offering training with a subsequent decline of watch technicians entering the field. The public image of the "little old watchmaker" laboriously repairing watches at his bench hour after hour has little appeal to the youth of today's space age. In view of this, it is understandable that existing horological schools have found it difficult to recruit students for their training programs, and that there has become a critical shortage of watch technicians.

Not to be overlooked as a contributing factor relating to this shortage is the increasing need in various industries for the unusual skills and precise workmanship that are historically associated with horology. As a result, many experienced watch technicians have been lured away from the watch industries. It has become apparent that industries engaged in micro-precision endeavors need technicians who are trained not only as horologists, but also in several related academic and technical areas. On the other hand, the dire need for horological specialists necessitates the development of training programs that will provide technicians to fill this need as well.

In the research and educational project conducted at the University of Illinois, considerable effort was expended to develop an educational climate necessary for the growth of training programs in this field, and to set patterns for future research pertinent to related aspects of this endeavor.

There was, however, one integrant of the research project that had to be abandoned due to the unfeasibility of making a comparative analysis of existing horological training programs in relation to a controlled program of only seven month's duration. It was unfortunate that the student body could not be recruited in time for a full nine months training program. This was due to the research project being started in the month of September, which was an unfavorable time to begin a nationwide recruitment of students. Also, the bulk of programmed instructional material to be used in the horological laboratory had to be compiled in advance of the training program and a multitude of other preparations had to be made. In addition, too many variables for a comprehensive research project involving other horological schools were found, although an informal interaction was established with some schools.

The writer, who has been the director of one of America's foremost horological schools for many years, recognizes that the University of Illinois presents an ideal environment for educational research efforts. In this respect, the University is eminently qualified to experiment with new educational techniques, with questions of course sequence and preferred examination techniques, and with assessment of students and tests concurrently. The flexibility in experimentation with different training schedules is basic to University of Illinois research programs.

It is felt that the benefits derived from this research project should accrue for many years to come, especially if existing horological

schools take advantage of this research in education. Furthermore, it is expected that this report will be far-reaching in its impact on the entire industry, with special reference to the emergence of a new, glamorous and fascinating field of training - "Micro-Precision Technology."

William O. Smith, Jr.

ACKNOWLEDGEMENTS

This Horological and Micro-Precision Project was enhanced by the valuable contributions made by the following outstanding individuals:

Industry Advisory Committee

Carleton Broer, Past President, American Gem Society
R.B. Hally, General Time Corporation
Harry Henshel, President, Bulova Watch Company
Stanley House, Executive Director, Watch Material and Jewelry Distributors of America, Inc.
Donald W. Leverenz, Director, Technical Trade Relations, Elgin National Watch Company
Floyd W. Marshall, President, Gem City College, School of Horology
E.H. Parkhurst, Jr., Research and Education Council, American Watchmakers Institute
Victor Paul, Chairman of the Board, Retail Jewelers of America, Inc.
Jerome Robbins, President, Elgin National Watch Company
Arthur Sinkler, President, Hamilton Watch Company

Faculty

| | |
|-----------------------|---|
| Robert Deane Bradley | Micro-Precision Electronics and Basic Electricity |
| Robert E. Chapdu | Communications Skills, Second Term |
| Richard A. Clarke | Applied Economics |
| Thomas C. Hartley | Technical Mathematics |
| A. Gray Lawrence | Horology Laboratory |
| Edwin C. McClintock | Communications Skills, First Term |
| David C. O'Bryant | Technical Drafting |
| William O. Smith, Jr. | Horology Laboratory |
| Hugh G. Wales | Applied Economics |
| Harish Betra | Research Assistant |
| Goodwin Petersen | Research Assistant |

Technical Consultants

Professor Daniel S. Babb, Department of Electrical Engineering, University of Illinois
Richard P. Beck, Division of University Extension, University of Illinois
James W. Cummings, Coordinated Science Laboratory, University of Illinois
Professor Harold N. Hayward, Measurement Program, University of Illinois
Sandor Molnar, Department of Physical Education, University of Illinois
Professor Timothy J. Nugent, Division of Rehabilitation Educational Service, University of Illinois
Dr. R. Norman Peacock, Department of Physics, University of Illinois
Dr. Richard H. Pohndorf, Department of Physical Education, University of Illinois

David Reyes-Guerra, Department of General Engineering, University
of Illinois

Educational Consultant

Dr. William J. Schill, Department of Vocational and Technical
Education, University of Illinois

Acknowledgement is due with appreciation to the assistance provided
by the following manufacturing companies who supplied various materials
to the program:

Amphenol-Borg Corporation
C. & E. Marshall Company
Cybern-Education
Elgin National Watch Company
Hamilton Watch Company
Micro-Switch Company
Seiko Time Corporation

Simpson Instrument Company
Timex - U.S. Time Corporation
Triplett Company
Waltham Watch Company
Westclox - Division of General
Time

Grateful acknowledgement is extended to the following organizations,
company and watchmaking schools, all of whom helped with constructive
criticism and advice:

Organizations

American Watchmakers Institute
Watchmakers of Switzerland

Company

McDonnell Aircraft Corporation

Watchmaking Schools

Bowman Technical School
Joseph Bulova School of Watchmaking
Chicago School of Watchmaking
Edison Technical Institute
Gem City College, School of Horology
Houston Technical College
John A. O'Connell Technical Institute
Kilgore College
Oklahoma State University Technical School
St. Paul Technical-Vocational School
Spokane Technical and Vocational School
Tacoma Vocational-Technical Institute
Western Pennsylvania Horological Institute

Photographs by Robert Hegge

CONTENTS

| | Page |
|---|------|
| Foreword | iii |
| Acknowledgements | v |
| Introduction | 1 |
| Essentials of Preparing and Conducting a Course in Horology and Micro-Precision Technology | 7 |
| Students and Subjects Selected | 7 |
| Horology Laboratory | 7 |
| A. Atmosphere in the Laboratory | 8 |
| B. Attention to Detail | 8 |
| C. Group Instruction | 8 |
| D. Visual Aids and Objectives | 9 |
| E. Programmed Instruction Material | 9 |
| F. Operation Breakdown | 11 |
| G. Speed Methods and High Quality Workmanship | 11 |
| H. Pace Set for Difficult Tasks | 12 |
| I. Motivation | 12 |
| J. Demonstrations | 13 |
| K. Forming Good Habits | 16 |
| L. Home Study Assignments | 16 |
| M. Responsibility and Recognition | 17 |
| N. Transfer of Skills | 17 |
| O. Photo-milling Process | 17 |
| P. Examinations | 17 |
| American Watchmakers Institute Certified Master Watchmaker Examination | 18 |
| Conducting A.W.I. Examination to Horological and Micro- Precision Students | 19 |
| Tutor Teaching Machines | 21 |
| Micro-Precision Electronics | 23 |
| Technical Mathematics | 23 |
| Technical Drafting | 24 |
| Applied Economics | 26 |
| Communications | 26 |
| New Proposed Curriculum | 26 |

CONTENTS (CONTINUED)

| | Page |
|---|------|
| Texts and References | 26 |
| Horology and Micro-Precision Technology Seven-Month Training Program - Curriculum Outline | 28 |
| Course Outlines | 30 |
| Horology Laboratory I, First Phase - Preparatory Horology . | 30 |
| Horology Laboratory I, Second Phase - Micro-Precision Machining | 33 |
| Horology Laboratory I, Third Phase - Advanced Junior | 36 |
| Horology Laboratory II, First Phase - Complete Work | 41 |
| Horology Laboratory II, Second Phase - Shop Practice | 45 |
| Horology Laboratory II, Third Phase - Practical Review | 50 |
| Basic Electricity | 51 |
| Micro-Precision Electronics | 53 |
| Technical Drafting | 56 |
| Technical Mathematics | 63 |
| Applied Economics | 67 |
| Communications Skills | 70 |
| Results and Findings | 74 |
| Further Investigation Needed | 77 |
| Conclusions and Recommendations | 79 |
| New Proposed Certificate Horological Curriculum | 83 |
| New Proposed Associate Degree Micro-Precision Curriculum .. | 84 |
| Chronological Record of Horological and Micro-Precision Laboratory Sessions | 86 |
| Appendixes | 115 |
| A. Disassembly and Assembly Procedure - Programmed Instruction Booklet | 115 |
| B. The Detached Lever Escapement (Function and Adjustment) | 154 |
| C. Sixteen Point Checking System and Work Sheet | 195 |
| D. Incline Gravity Clock -JETS Project | 208 |
| E. Chronograph Illustrations | 217 |
| F. Color Code for Watch Bench Drawers, Proper Arrangement of Tools in Bench, and Diagram of Punch Arrangement in Staking Tool Set | 231 |

CONTENTS (CONTINUED)

| | Page |
|--|------|
| G. Samples of Questions Used in Written Examinations for Horological Laboratory Studies | 236 |
| H. Horological Schools Questionnaires | 245 |

INTRODUCTION

The Horological and Micro-Precision Project of the University of Illinois, which commenced on September 1, 1966, was sponsored by a grant of the U.S. Office of Health, Education and Welfare. The purpose of this research was: (1) to establish better methods of training technicians for the horological and industrial fields; (2) to encourage more young people to investigate horological and micro-precision work as a career; (3) to train a group of students who would be employable in diverse horological and industrial areas; and (4) to help horological schools in the United States in their training programs through the benefits of this research and demonstration project.

The horologist in recent years has been employed by many diverse industries, especially in the area of micro-precision and microminiaturization. The know-how, developed techniques and skills associated with the field of horology are now as never before of paramount value to such areas of technology as: miniaturization of controls for space exploration, timing vault devices, medical apparatus in microminiaturization, precision time fuses, communication and data processing, not to mention general microminiaturization which is permeating vast areas of instrumentation development.

The need for technicians trained in this vital field is rapidly becoming critical. The horological and micro-precision industries are rightly concerned about the lack of qualified technicians to supply their needs and have supported this research project whole-heartedly. One of the main objectives of this research project was to develop a training program that blends industry's needs with watchmaking skills. To accomplish this, a course had to be designed to cut across several recognized fields of technology - mechanics, micro-machining, electricity and electronics. In addition, since there is also a scarcity of horologists to work in the watchmaking industries, efforts were made to improve teaching methods in this field so that horologists could be trained more efficiently.

The project was divided into two parts. The first period of five months was spent in curriculum planning, preparation of class materials and in equipping the horology laboratory, while the second period of seven months was used to train a group of students in horological and micro-precision skills.

There are many problems that exist in the horological field, especially in reference to training programs. In general, present training periods are unnecessarily long and they are not designed to keep the students interested and motivated. Many existing training programs are tied to tradition and have not been updated in accordance with the needs of today. In addition, horological schools as yet have not redesigned their programs to demonstrate the transferability of watchmaking skills to certain related areas of instrumentation. These things have helped bring about a critical shortage of watch and micro-precision technicians.

In accordance with the objectives and the project's plans to seek solutions to the various problems in this field, a national conference for watchmaking educators and industry leaders was held on October 29 and 30, 1966 in Chicago. The objectives of the conference were to study and report on the changing needs of watchmaking education today, with special regard to the challenges facing educators, retailers, suppliers, importers and manufacturers in the American watchmaking industry and related micro-precision industries. Discussion focussed on the latest research and educational techniques which have been successfully applied to the solution of problems in watchmaking and micro-precision education. The conference also explored various avenues of assistance which are open to the educational training institutions. A discussion of these topics included the coverage of such subjects as vocational training in watchmaking and micro-precision industries, the new methods now available through correspondence courses, schools of watchmaking, and industry training programs; the new need in industry at the professional level; and the professional teaching personnel available to handle these highly-skilled activities. The conferees discussed and evaluated methods by which watch technicians and micro-precision specialists can be trained through educational programs and university courses. A mutual exchange of ideas was brought about which has proven to be invaluable in the preparation of materials for the demonstration phase of the project.

In order to ascertain at first hand the needs of industry for micro-precision technicians, the Horological and Micro-Precision staff visited various industries engaging in micro-precision work. The objective was to blend industry's needs with the horologists' skills. Also, in order to acquire any new techniques and speed methods that may be employed in training programs throughout the nation, a visit to horological schools was made which proved to be of great value.

To interest the youth in this field and to have an opportunity to talk to watchmakers at various association meetings, technical educational seminars were held in several parts of the United States. In addition, in order to interest the science-minded youth of America in this fascinating and unusual field, a project was developed in which the JETS (Junior Engineering Technical Society, Inc.) could participate. This consisted of an inclined clock which can be made by youngsters. (See Appendix D).

Since one of the main objectives of this research project was to search out new methods of training technicians more efficiently, two educational guides for students were written and illustrated by the Horological and Micro-Precision staff for use in the laboratory which enabled the students to learn step by step the procedure for disassembly and assembly of a watch movement with reference to the function of each part and hazards to be avoided. Also, the function and adjustment of the escapement were clearly presented enabling the students to grasp this difficult subject more readily. These programmed instruction guides were prepared to demonstrate how technical instructional material should be organized and presented in order to obtain the best results in the classroom. It is felt that these programmed instruction tech-

niques should be developed to cover every subject in the field of horology. Such works are much needed and would be of tremendous benefit to upgrading the entire industry.

The Horological and Micro-Precision staff met with educators from the College of Engineering, the College of Education, and the College of Commerce and Business Administration of the University of Illinois to discuss programmed instruction and the use of the tutor teaching machine. A curriculum was prepared for the training program and a plan was formulated to use the tutor teaching programmed instruction course in basic electricity in an experimental program in which the class would be divided in half; one section of the class would receive classroom instruction, while the other section of the class would receive instruction through the use of the tutor teaching machine.

A great deal of consultation with experts in various fields was necessary in order to make the curriculum outline fit the training needs of the micro-precision oriented industries and the field of horology. In addition, the course was prepared for training students on an accelerated basis, eliminating all possible lost motion that is inherent in most traditional courses, keeping in mind the prime objective of covering only those subjects necessary to train a student to be proficient in the field and, therefore, employable at the end of his course of training.

The need for those who have had training in the field of micro-precision skills is quite substantial. There are a number of sources for evidence of this point, but perhaps the most convincing is that which has grown out of the research work in connection with the Micro-Precision course, offered at the University of Illinois during the past year.

In April, 1964 the University of Illinois held a national conference on Manpower Training and Development for the watchmaking and precision industries. This conference was attended by industry leaders, manpower specialists, and educators from various sections of the United States. A few quotations from participants in this conference will be helpful in assessing the needs for micro-precision and watch technicians' skills.

For example, Mr. Alfred N. Siegel, Head of the Electro-mechanical development laboratory of McDonnell Aircraft Corporation, a leader in the aero-space industry, has said: "The technician is very, very important in what we do in the aero-space industry. They work to a .0002 inch tolerance under ordinary working conditions. If you trace back that man's education, you would discover that 90 per cent of the time he had a vocational school training. He didn't have a degree of any kind. This type of man is very scarce. In research and development work at McDonnell, he is hard to find."

Mr. Howard J. Roen, Superintendent of Manufacturing Engineering, Micro-Switch Corporation, Moline, Illinois, has said: "Our company employs several fine technicians who have been trained as watchmakers, as I am sure every micro-precision industry does."

Mr. H.T. Eckstrom, Director of Personnel Services of Minneapolis Honeywell, Inc., has said: "We do need today the craftsmen with watch-making skills, and I am certain we all agree that tomorrow we shall need these skills a thousand times more. In order to meet our objectives, we must upgrade our training in this field."

Mr. William O. Bennett, Vice President for Research and Engineering, Bulova Watch Company, has said: "Just a decade ago, the jeweled watch-making industry, and the micro-machining industry in general, could count almost 100 per cent on metallurgy and the laws of mechanical forces to answer all the questions. Now we have to contend with electronics, plastic moulding, and virtually every science or technology involving physical phenomena, plus a thorough growing knowledge of mathematics."

The comments of these industry leaders is confirmed in the proceedings of the National Conference on Manpower Training and Development for watchmaking and precision industries, for industry leaders, manpower specialists and educators, by Jerry S. Dobrovolny, Editor, Department of General Engineering, University of Illinois, April, 1964. In summarizing the contents of the published proceedings, the following statement sets forth the ideas on that conference: The drain on this very small reservoir of skilled people to meet new demands in aero-space and micro-precision activities has been severe. Compounding this problem is the fact that watch technicians and micro-precision specialists who generally represent a high age group, have been retiring from the labor force in substantial numbers, and the training of new watchmakers has failed to keep pace both in quantity and quality with the needs for workers in the watch technician field alone. Hence, the shortage is affecting not only the watch technicians phase of the work, but also the whole range of micro-precision activities and defense work related to it.

Perhaps the most convincing evidence of the need for horological and micro-precision technicians has been demonstrated by the number of positions that were offered to the graduating students of the University of Illinois Horological and Micro-Precision Project. Many fine job opportunities, both in the horological profession as well as the micro-precision industries went begging for lack of students to fill these positions. In fact, two large concerns each made an offer to employ the entire class.

Of the 23 graduates, 11 went to work as watch technicians in jewelry stores (one purchased his own jewelry store), and one of the 11 plans to receive training in jewelry repair and hand engraving, and another may take further training in electronics.

Four graduates were employed by Westclox Company in LaSalle, Illinois; one as a supervisor, one as a time study inspector, and two as apprentices in a four-year training program in precision tool-making, all at substantial incomes.

One graduate intended to work at the Hamilton Watch Company in Lancaster, Pennsylvania, and then to be readmitted to Pennsylvania State University.

Three other graduates planned to be readmitted to college to complete studies which they interrupted to take part in this program. One has returned to California to enroll at Imperial Valley College; one is a senior at the University of Illinois, working toward a bachelor's degree in Latin American Studies; and one has returned to Selma, California to complete pharmaceutical training, and is also working two days a week in a jewelry store.

Two other graduates planned to take positions with instrument companies in Texas and New Mexico.

Two graduates expected to be called into military service and, therefore, had made no other commitments at the time of their graduation.

Since this was the first attempt to formulate a course in horology and micro-precision training, it is felt that a detailed report would be most valuable to other institutions in developing such a training program. Thus, consideration of all the things that have been learned in this research project and the method of presentation in a programmed instruction format, along with the educational aids that were employed and the techniques that were used in teaching, are dealt with in this report.



Figure 1 shows the first Horological and Micro-Precision class assembled in front of the Horological and Micro-Precision Laboratory and office building at the University of Illinois.

Figure 2 shows part of the laboratory classroom where the students spent four hours per day learning and practicing micro-precision techniques. A great deal of time was devoted to watchmaking technology which is the cornerstone for micro-precision training.



ESSENTIALS OF PREPARING AND CONDUCTING A COURSE IN
HOROLOGY AND MICRO-PRECISION TECHNOLOGY

Students and Subjects Selected

The Horological and Micro-Precision training program conducted at the University of Illinois was designed to train a group of students to have employable skills in the horological field and in compatible micro-miniaturization industries.

Requirements for participants in the training program were that the students be under 25 years of age, graduates of an approved high school, have completed secondary-school courses in algebra, and possess the motivation and learning ability to complete the program successfully. In addition to consideration of personal qualifications, participants were selected geographically to assist in the strategic location and strengthening of watchmaking and technological programs throughout the United States. Twenty-nine students were enrolled in the training program, but five were dismissed due to poor grades, and one left due to poor health. Although their studies were rigorous and exacting, no student dropped out of the program.

Due to the relatively short training program of only seven months, an accelerated course was proposed and designed. Traditional ways of teaching watchmaking in depth regardless of contemporary needs were disregarded. Thus, in the horological laboratory, the essence of horology for today was the basis around which the curriculum was developed. In addition to the introductory horology course, other subjects selected and designed specifically to implement and reinforce the laboratory sessions were: Technical Mathematics, Technical Drafting, Micro-Precision Electronics, Communications, Basic Electricity, and Applied Economics. The horology course was conducted in the laboratory for four hours each morning, from 8:00 a.m. to 12 noon. Three hours per day were allotted to laboratory work and one hour was devoted to classroom instruction. The other courses were scheduled for the afternoon as follows:

| | |
|-----------------------------|---------------------------------------|
| Technical Mathematics | - five hours per week, for two terms |
| Technical Drafting | - six hours per week, for one term |
| Micro-Precision Electronics | - six hours per week, for one term |
| Communications | - two hours per week, for two terms |
| Basic Electricity | - short three-week course |
| Applied Economics | - three hours per week, for two terms |

Horology Laboratory

The sizeable proportion of the effort expended in this project centered on the preparation and development of new techniques of training students in the horological laboratory phase of instruction. This was to be expected as the subject of horology, in which all students in this training program majored, consisted of over one-half the total training time required for the completion of the entire program. Needless to say, the other subjects related to the horology laboratory

work - Technical Mathematics, Technical Drafting, Micro-Precision Electronics, Communications, Basic Electricity, and Applied Economics - were specially designed and prepared for this program to broaden the students' knowledge in areas that are of prime importance to anyone working in a micro-precision field. However, in general, standard texts and procedures with certain changes were easily adapted for these related subjects.

For this reason, the bulk of the following information, with exception to statements clearly made to the contrary, deals almost exclusively with the horology laboratory work.

A. Atmosphere in the Laboratory

In order to create a professional atmosphere, the male students were required to wear ties and white coats in the laboratory. This set the tone for neatness, cleanliness and order that was expected of the students in every phase of study. The immediate benefits notwithstanding, the habits formed would hopefully prevail throughout their future endeavors.

To promote a cheerful atmosphere and facilitate learning, good lighting, air-conditioning, and sufficient working space were provided. To discourage talking among the students, the work benches were set at an angle making conversation with one another rather difficult. The laboratory was fully equipped with the latest scientific equipment available.

B. Attention to Detail

In a laboratory class, it is always the little things that are so important to a smooth operation or running of a class. Such things as the students keeping their tools in the proper drawers of their bench, and keeping the tools in good condition, are especially important. To accomplish this, two things were done. First, at the beginning of the course, students were issued a list of all the tools that they were to receive and the drawers in which these tools should be placed. A color code was placed on the drawers to designate the particular drawer for each tool. Second, an inspection was made every week of the condition of the screwdrivers, tweezers, position of tools in the bench and cleanliness of the bench. (See Appendix F.)

This attention to detail is necessary to establish good habits early in the training.

C. Group Instruction

It is believed that having the class move along and perform as a group helped tremendously. Many of the present-day horological schools have individual instruction, due to students entering into training at practically any time they wish to enroll. The Horological and Micro-Precision class did not have this disadvantage as all students were started at the same time and, therefore, progressed as a class unit.

Thus, any problems that developed could immediately be brought to the attention of the entire group. If, for example, one student had a particular problem, all the other students being on the same subject could be informed of the problem and the solution, so that all would gain. Also, since all the students were on the same phase of instruction, lectures were given to the entire class and question and answer sessions could be held which would benefit the entire group.

D. Visual Aids and Objectives

To appeal to the students' eyes as well as their ears, visual aids such as tutor training machines, color slides, and models were employed.

In this respect, a set of slides was produced dealing with the fundamentals, functions and adjustment of various constructions of chronograph mechanisms. A set of drawings in accordance with the slides was printed so that each student could have a copy to be used in conjunction with the presentation. The students were required to follow the printed illustrations as the corresponding slides were projected on the screen and to make notes and indicate areas of importance in the drawings.

Whenever this visual aids technique is employed, the room must be darkened no more than is necessary for good projection. Still, the room must have sufficient light so that the students can work with the printed diagrams. The printed illustrations used in conjunction with the slide presentation are shown in Appendix E.

In connection with preparing visual aids for this project, the method outlined in the textbook Preparing Instructional Objectives, by Robert F. Mager, Fearon Publishers, 1962, was adopted in presenting subject material. It is quite evident that the method of training in a micro-precision field must be suited to the unusual characteristics of the field itself. In the past, horological schools have set as their objective a high degree of perfection in every task the student performed. This meant that the student could spend many weeks on a single project in order to develop the necessary know-how and manipulative skills to reach that objective. Under these circumstances, the repetition or practice that was necessary for the development of the techniques needed to complete a particular project often became so oppressive that the students lost interest. To avoid this and to foster a learning situation that would hold the students' interest, great care was exercised in preparing and planning the entire training program.

E. Programmed Instruction Material

In using the specially prepared programmed instructional guides, the students were required to follow the step by step procedure outline without help from the instructor. There were no lectures previously given on the subjects covered by the guides, nor was individual consultation permitted unless the student ran into difficulty. (See Appendixes A and B.)

This was done in order to determine how effective these guides were in familiarizing the student with certain subject material and techniques covered in the guides.

In conjunction with the instructional guide dealing with the lever escapement, a 12-inch escapement model was used (one escapement model for every two students). The students were then required to make adjustments one at a time to each part of the escapement in accordance with the procedure outlined in the guide. The escapement models were then checked by the instructors to determine whether or not the student understood the material presented. For further information on programmed instruction material, see "Tutor Teaching Machines", page 21.

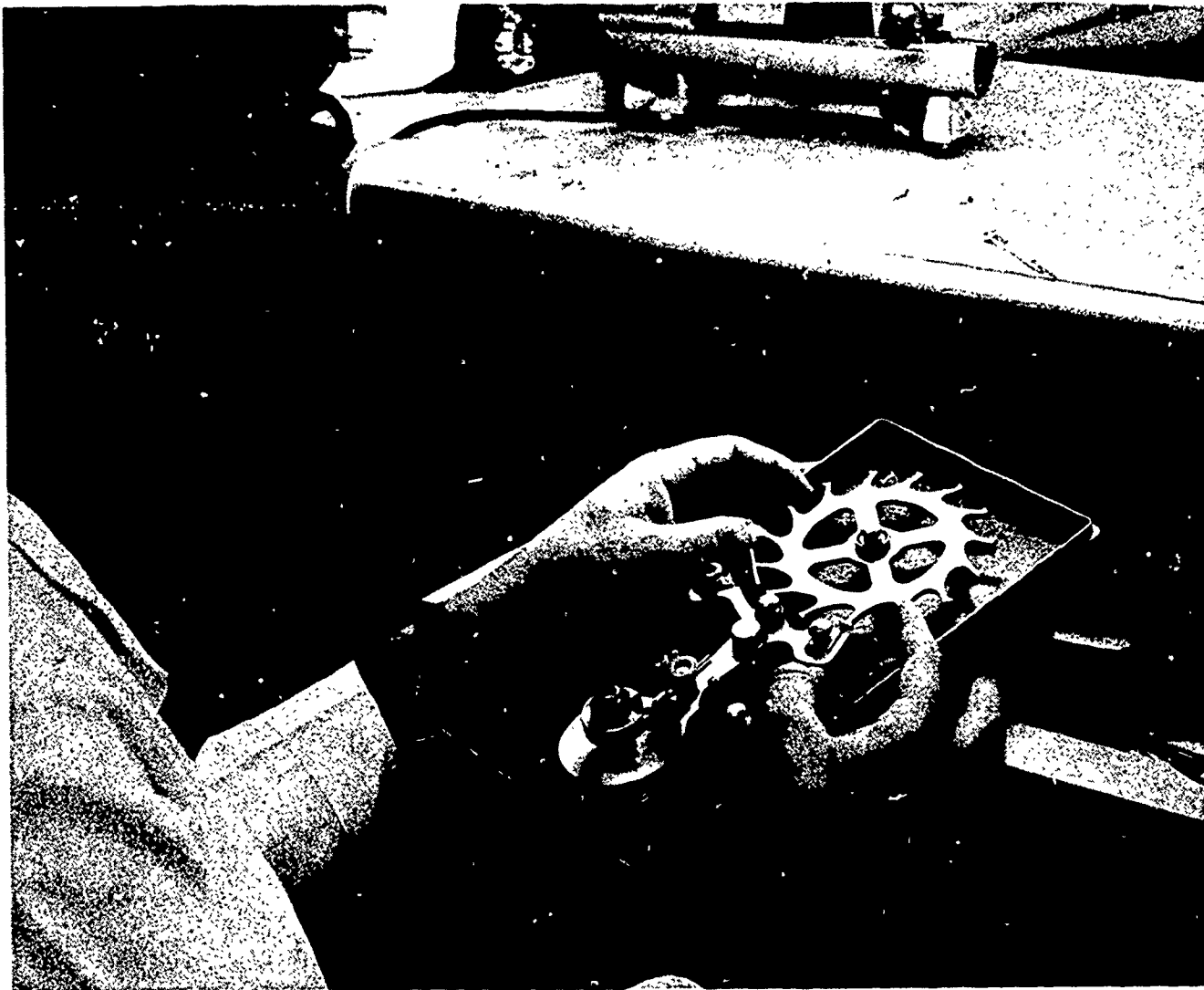

Figure 3 shows a student making the necessary adjustments on a large model to properly position all the various components of the detached lever escapement. These adjustments must be made very precisely in order that this mechanism will function properly. The student must become proficient in making these adjustments on the enlarged model before proceeding to work on the small and delicate mechanism, which would be less than one-quarter the size of a dime.

F. Operation Breakdown

It was especially important in every phase of instruction to not only cover the "how" as a matter of direction, but also the "why" which is a matter of thought. In addition, in order to present a subject clearly to the student, it was most important that the instructor prepare a summary, including minimum requirements for the students, and an operation breakdown of topics. It is known that if the instructor does not have such a guide in presenting the topic, certain important details can be missed. In every topic that was presented, there was a certain logical step by step procedure that was followed. The breakdown list covered the following:

1. What
2. How
3. Why
4. Tools
5. Skills

Basically, by having an operation breakdown and by considering the five factors listed above which were rigidly followed in every respect, a definite standard presentation sequence was established which was designed to be most advantageous to the students. It was necessary that the instructors spend some time each day in careful preparation of the following day's presentation.

In the work phase of laboratory training, a 16 point checking procedure was developed. The students were required to follow this checking procedure very closely and to make each check with the instructors. A work sheet was used in conjunction with the 16 point checking procedure to indicate the student's progress. Each time the student made one of the 16 checks with the instructor, the instructor would record the time the check was made in the space provided for that purpose on the work sheet. By looking at a student's work sheet, one could easily tell whether or not the student was progressing as rapidly as required.

In addition, the areas in which the student was having difficulty were quite apparent by observing the length of time it took for the student to make each check.

G. Speed Methods and High Quality Workmanship

During the five months of research prior to the student training program, speed methods were developed for use in the laboratory, and special teaching techniques were incorporated. The emphasis on speed methods would give the students a basis for accomplishing tasks in the shortest possible time. Hence, techniques that would give the students the greatest possible production rate as they became proficient were almost wholly taught. In some instances, an easier alternate method which took more time to complete would also be explained. However, the students were reminded that their main objective was to become proficient using methods that would eventually bring about the best results in the least time.

In order to obtain a high degree of perfection needed for the final stages of training, the curriculum was prepared to bring about a re-inforcement of each preceding subject. One way this was accomplished was through scheduling of complete work projects that incorporated all preceding practical work projects into a complete unit. (See Motivation for more detail.)

H. Pace Set for Difficult Tasks

It was decided by the Horological and Micro-Precision staff that whenever possible, the students would be taught the theoretical and technical aspects of a subject before they would be allowed to perform at the bench. In this way, it was expected that the student could then concentrate on the manipulative skills needed to accomplish the desired effect. The result and reinforce the theory learned earlier.

In addition the pace at which the students should progress was established at the outset, in order to give the students an idea of what would be expected of them. Furthermore, in order to get the students to immediately face the facts about the intricacies and delicateness of many aspects of this work, the students were in the very beginning given a sampling of many of the more difficult areas of training. The instructors at this point did not expect good performance but kept the objective in mind of just orienting the students. Most of all, great care was exercised during this period to keep the students from becoming discouraged. The objective here was to quickly give the students a perspective of what they would eventually be required to do in a highly proficient manner.

It was felt that such phases of horology as hairspring work, which requires great manipulative skills, should be taught step by step with a break of a week or so between each step. In accord with this concept, the students started on hairspring work very early in their training and kept coming back to it, covering the more advanced phases of this work on hairsprings practically over the entire length of the course. In nearly every difficult subject, the student proceeded just far enough so that he did not become nervous, upset or unmotivated before switching to a new subject.

In order to utilize every minute of laboratory time, all the students were given extra tasks to perform at times when they were waiting for equipment or for the instructor. This helped the students to realize that there was no lost motion in the training program and they were expected to make proper use of laboratory time in productive endeavors.

I. Motivation

In preparing a course for horology and micro-precision technology, there were a number of factors that had to be taken into account. It has been said that more people are trained out of horology than are trained into it. This simply means that the drop-out rate is fairly high in training programs because, in general, such programs are not

designed to keep the students motivated. In many cases, students are required to repeat certain tasks so many times in order to develop particular manipulative skills that they lose interest and just fritter away their time.

Since a micro-precision field demands such a high degree of concentration and skill and can become very tedious at times, due to the inherent confinement of the work, great care must be exercised not to allow the student to work too long on a single project. In order to do this the student should be expected, on his first encounter with a difficult activity, to do only reasonably good work.

A great deal of repetition is required over a long period of time to develop a skill to a high degree. However, the Horological and Micro-Precision staff felt that a course could be developed that would allow the students to progress rapidly in order to help keep the students motivated, and yet in the final analysis, develop the students' skills and ability through the transfer of skills from one subject to another. In this way, it was expected that the students would eventually, toward the end of their training program, reach a fairly high degree of perfection. Considerable attention was devoted to this concept in the arrangement of topic sequencing in preparing this training program.

Every instructor in the field knows the areas which present a real challenge to him in reference to motivating the students. It is not only important that these areas of training be broken up whenever possible and taught to the students little by little, but the more interesting areas of training should be alternated between the duller and/or more difficult topics.

J. Demonstrations

In some of the demonstrations that were made on various aspects of the laboratory work, a student was used as an assistant. The instructor then explained the various operations that the assistant was performing as a demonstration. The intent was to create a better atmosphere as it showed a liaison between the instructor and the student. A noticeable increase in attention was apparent when such demonstrations were given. After a demonstration, the students were always questioned about the things that must be known on a particular job or operation. For example, the key points, as well as any hazards or special safety precautions that must be followed were covered.

Especially in a micro-precision field, it is often difficult for the student to see what exactly is taking place when a demonstration is given, particularly on a small, intricate mechanism. The instructor, in making such demonstrations, must always keep in mind that he should work very slowly to avoid any quick movements, always repeating the demonstration when necessary, and summarizing the basic things that should be remembered. It is always best after a demonstration to call upon a student to explain the practical application that is present in the demonstration.

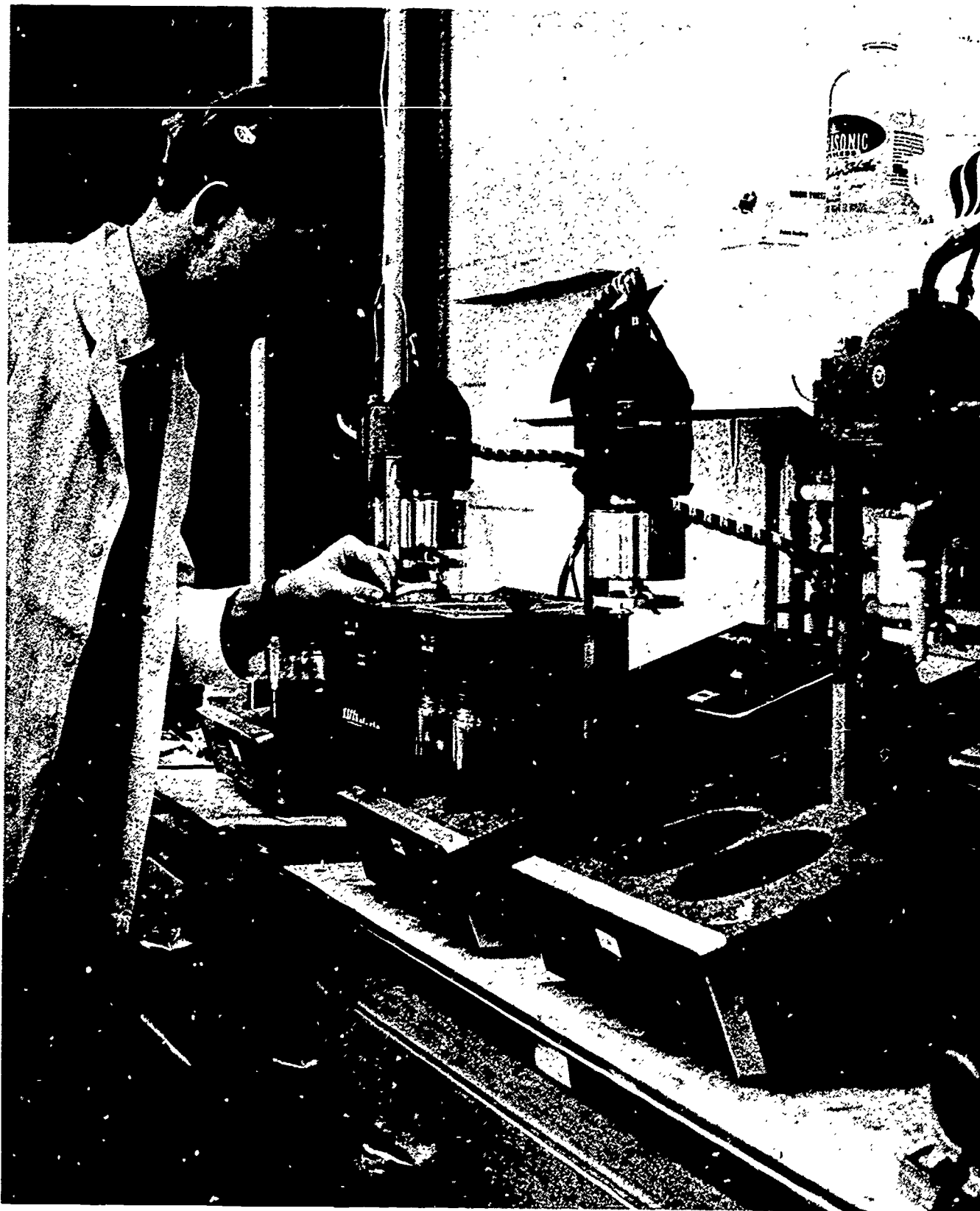

In figure 4 we show a micro-precision student about to use an ultrasonic cleaning machine to clean a micro-precision instrument. The parts of the mechanism are placed in a basket which is attached to the machine and submerged in various solutions which are activated ultrasonically to bring about the microscopic cleanliness of the parts needed for this precision work.



Figure 5 shows a micro-precision student centering a hairspring which is attached to the axle of the coil assembly. Since these hairsprings are soft and delicate, a slight slip of the tweezers can cause irreparable damage to the hairspring.

K. Forming Good Habits

A few comments were given every morning about various aspects of ordering material. The students were then required to use their catalogs and look up certain materials by identifying the movement, the part, dimensions when necessary, and so forth. A few minutes spent every day on such topics gave the students a better understanding of the topic than if they were required to assimilate all this information in a very short span of time.

Part of every educational endeavor is concerned with having the students form certain habits in areas of training in which a habitual sequence can be established through repetition. This can help prevent errors or mistakes from occurring. Here again, it is only through the little but important things being accomplished through habit that one can develop speed in one's work. Preparing the student to form good habits is the cornerstone upon which a good technical program in this field must be built. If a technician has not developed good habits in his work, great difficulty arises especially when he is put under stress and is working with several timekeeping instruments at one time.

When the students were working at a bench, the instructor moved from one station to the next giving encouragement or asking questions. The instructor scrutinized the students' working characteristics and this is most important in the early stages of training. Poor techniques being employed must be stopped quickly before the student forms a habit that is detrimental to good performance.

After the first term, the instructors were then situated at benches and the students were required to come to the instructors for checking, and individual instruction. When this is done, it is most important that the students are not allowed to line up waiting to be checked by the instructor as this would waste the students' time.

To solve this problem, the students, when they were ready to be checked, were required to place their work sheet on the instructors' benches and then go back to work. They were then called one at a time to the instructor's bench. This system worked out very well and prevented students from losing time waiting for the instructors.

L. Home Study Assignments

Another factor that was considered carefully was the assignment of homework for the horology class. Although homework is standard procedure for academic courses, many horological schools do not require the students to do any outside work. It was felt, however, that there were many advantages to assigning outside work for the horology class. The assigned outside work helped keep the students' minds on the subject, which is very important in this type of training. In addition, any student who had trouble with a particular subject was given special assignments and articles to read. Although skills could not be developed outside the laboratory, the extra assignments helped the students develop a better understanding of the subject. It was expected that this, in turn, would bring about a deeper concentration and more rapid

development of skills in the laboratory.

M. Responsibility and Recognition

One of the most important contributions that was made to the development of the students was the delegation of responsibility to them in general. The instructors from the beginning expected outstanding performance, and the students sensing this confidence in them, strove to perform to the best of their ability. They were treated as adults and were given as much responsibility in the performance of their tasks as one would dare risk in a program of this nature. Experimentation was especially encouraged. This helped bring about a great deal of interest and discussion that would hopefully develop the students' knowledge of the field.

Students should always be given appropriate recognition for an achievement. One way this can be done is by bringing high performance in any task to the attention of the entire class. Throughout the training program, the instructors never hesitated to give a word of encouragement to students who were having difficulty, and above all, a student was never allowed to be ridiculed by another student for asking a question that seemed stupid at the time or for making a mistake. This is important in a training program which can become rather frustrating at times due to the involvement of students with small and intricate parts and components which are sometimes difficult to handle and are easily damaged or lost.

N. Transfer of Skills

In order to show the student how his skills can be transferred to other areas such as instrumentation, the students were required to work with voltmeters and milliammeters and to completely overhaul and calibrate these mechanisms. The students performed so well in this new area, that they became highly motivated over the realization that they could perform successfully and with little difficulty in other areas as well as in the horological field.

O. Photo-milling Process

Verbal lectures as well as manual demonstrations were given to the students in photo-milling. It is apparent that photo-milling is a relatively newly developed technique of manufacturing small and intricate parts. This process is being employed to a great extent in industries engaged in micro-precision work. This is a rapidly expanding field and one in which all micro-precision students should be trained. A great deal of time was not devoted to this aspect of micro-precision technology, due to the limited time that was available in the training program. However, the students were shown the process and lectured on not only the process, but the areas in which it can be adapted to the making of various micro-precision components and parts.

P. Examinations

The students were given a written examination after each month of training, and they were graded on practical bench work which was turned

in weekly.

In testing the students in the laboratory, an experiment was made on one examination which consisted of giving a written test to eight students at a time each day for a period of three days. In doing this, it was expected that there would be some transfer of information. The examination that was prepared covered generally the entire course of training up to that particular point at which the test was given. Since the students did not know which persons were going to be selected each day, there was a great deal more discussion and activity among the students in preparing for the examination than is usually evident in most examinations that had been previously given. Unknown to the students, it was arranged that the students selected to take the examination on the first day were the "A" students, the second group were the "B" students, and the third group were the "C" students. This gave the slower students a longer period of time in which to study and they were motivated by the comments that were made by the students who had already taken the examination. It was felt that the additional studying, preparations and discussions that were evident prior to the examination, helped considerably.

The students were informed that they would be graded or rated on a number of factors that would be most important to a future employer such as: interest, cooperation, consideration for others, self-reliance, readiness to assume responsibility, appearance and neatness, leadership ability, social qualities and industriousness. A copy of the confidential rating form is included in Appendix G.

American Watchmakers Institute Certified Master Watchmaker Examination

One of the objectives of the training program in horology and micro-precision technology, recently concluded at the University of Illinois, was the employability of the graduates. The emphasis on horology in this unique research program was due to the critical need for watch technicians and the relevance of watchmaking skills to micro-precision technology in general.

The American Watchmakers Institute (A.W.I.) Certified Master Watchmaker Examination was given at the end of the training program to: (1) obtain a measure of the students' ability in relation to expert master certified craftsmen in the field, and (2) determine the advantages and disadvantages of using this particular examination as a longitudinal test for watchmaking and micro-precision trainees.

First, it must be stated that from this educational research project, there were two students from the 22 who took the Certified Master Watchmaker Examination who passed all phases of the examination satisfactorily and have become Certified Master Watchmakers.

In view of the A.W.I. booklet about information on certification, there are tentatively 13 students who can retake the portion of the examination they failed. The following is taken from the A.W.I. information on certification:

"In the event you fail one part of the examination, you may apply for re-examination in that one part. You may retake the portion you failed only once."

A.W.I. has already contacted the students who can retake the examination. The Horological and Micro-Precision staff are likewise presently contacting these students to have them review certain areas of training and to encourage them to retake the portion of the examination they failed. It is expected that many of these graduate students will be certified soon by A.W.I.

In view of the few students from the Horological and Micro-Precision Project who have passed this examination, some criticism has been raised in this regard. However, due to certain circumstances, which will be presently explained, and due to the fact that this examination was given to a complete class for the first time on an experimental basis, such criticism is unfounded as there has been no previous standard of comparison upon which a sound judgement can be based.

In addition, the A.W.I. Certified Master Watchmaker Examination only tested the students in one aspect of the overall training program: namely, the horological laboratory studies.

In this respect, the examination was inadequate for this particular training program as it did not even touch upon several parts of the program such as mathematics, communications, applied economics and drafting. Furthermore, in electricity and electronics, only the application to horology was tested.

Conducting A.W.I. Examination to Horological and Micro-Precision Students

The Certified Master Watchmaker Examination was given to a group of 22 students over a two-day period. Since the maximum time allowed for the examination is 14 hours, the students spent approximately seven hours per day in this endeavor. The written part of the examination was taken first and then the students proceeded to the practical bench work portion of the examination. The test was conducted on Saturday and Sunday, August 26 and 27, 1967.

Those institutions interested in giving the A.W.I. Certified Master Watchmaker Examination should take into consideration the things that were learned about conducting such an examination which are presented in the following.

The multiplicity of variables which related to the administration of the A.W.I. Certified Master Watchmaker Examination are sufficient to raise doubts about the validity of the results which were obtained.

The A.W.I. examination, which a watchmaker in the field is allowed to take over a 30-day period, permits him to work at it only when he is at his best. However, the Horological and Micro-Precision students did not have this advantage. As indicated above, the examination was concentrated into a two-day period for this class. This intensive testing for seven hours each day was, as one would expect, not con-

ducive to optimum conditions of body and mind necessary to good performance at the bench.

Another factor that contributed to the pressure on these students was the fact that the written part of the examination, which took about two hours, was given first. It was immediately apparent that the Swiss terminology and nomenclature of parts used in the test presented quite a problem to the students. In reference to automatic watches and chronographs, the students were taught the American terminology, which was not used in the examination. Terms such as "column wheel" and "coupling clutch" were used instead of "castle wheel" and "chronograph pivoted detent" respectively. The student knowing he had difficulty with this portion of the examination and he might have failed the entire examination as a consequence of this, became less confident, nervous and tense. This tension was discernible for the remainder of the day as the students were tested on the bench work. It was quite noticeable that their performance at the bench did not come up to their usual classroom level of accomplishment. Even many of the very exceptional students were running into trouble and having difficulty in areas in which they were normally exceedingly proficient.

Another element not to be overlooked in conducting an examination of bench practice in a group situation is that tension builds up rather rapidly and everyone is adversely affected by the difficulties encountered by anyone in the class. This pressure is not felt by the average watchmaker taking this examination at his own pace in the privacy of his shop or home workroom. In our own particular case, because of delayed delivery of the examination watches, the students did not work on the watches that were to be used for the examination prior to the test which placed the students at a definite disadvantage. Many problems were encountered, the worst of these being the improper fit of material supplied for the repair of the examination watches. Although genuine material was ordered, many of the balance staffs, for example, did not fit the balance unit properly. If the student had been allowed to work on these watches before submitting them for the A.W.I. examination, these difficulties would have been encountered and corrective measures would have been taken. It is believed that most watchmakers in the field who take the A.W.I. Certified Master Watchmaker Examination have previously worked on and become familiar with the watches they submit for the examination and have in advance selected the staffs and checked the fit. This is highly recommended to all those who intend to take the examination. For reasons previously mentioned, this was not done with the Horological and Micro-Precision students.

In conclusion, it is felt that if the A.W.I. examination is to be given, it should not be given to a whole class at one time and that students should not be restricted beyond those restrictions outlined for watchmakers in the field who take the examination. Furthermore, it is believed that those taking the examination should be informed of the terminology that will be used and the accepted nomenclature of parts that have been adopted for the examination.

In the future, when test instruments for evaluation examinations are considered, the use of the American Watchmakers Institute Certified

Master Watchmaker Examination can be administered again by taking into account the variety of variables mentioned above, which may bias the results of this certification examination.

Tutor Teaching Machines

The Auto Tutor Mark II teaching machine was used in covering a programmed course in basic electricity. This machine is an automatic, semi-random, access film projecting teaching machine. When properly developed, automated programmed instruction achieves full student participation and automatically instructs and corrects the student individually. It provides a self-pacing of learning and eliminates the need for constant supervision. The learning material is organized into small steps, leading the learner from the simple to the more complex. Systematic revisions of the course are possible on the basis of student learning. Likewise, a more systematic and formal approach to the development of instruction is possible.

The Auto Tutor Mark II teaching machine is designed to display one picture at a time on a back projection, nine by twelve inch view screen. Each frame is exposed along with a multiple choice question to test the student's understanding of the point presented. The student selects his choice of answers by pressing a button in a line of nine selector buttons, located to the right of the viewing screen. If he selects the correct answer, a new frame confirms the accuracy of his response then presents a new unit of information and a question on the new information. If the wrong answer is selected, different material appears. The nature of the error is then explained. Another and more simple principle is then presented and the student is directed back to the original question to be tested again. Immediate knowledge of the results is thereby provided to the student. There are some cases in which the selection of an incorrect answer results in a sub-sequence. This series of frames reviews the appropriate principles and concepts and then returns the student to the main stream of the program.

Self-pacing is an inherent characteristic since the student's rate of progress is at all times dictated by his capacity to comprehend the material presented. At the same time, the student is motivated to continue his study through the inherent characteristics of the program self-growth and achievement.

To help determine the effectiveness of using a teaching machine, an experiment was conducted in training students in basic electricity. For this experiment the students were separated into two groups. One group received classroom instruction, while the other group used the tutor teachers.

A battery of six tests was administered to the 23 students. For purposes of assessing initial understanding of electronics principles, a Basic Electronics Test based on material presented in a typical basic electronics course was designed. An item analysis of the results identified 50 items to be retained for use in post-tests. Students were informed that test results would be a part of their grade determination.

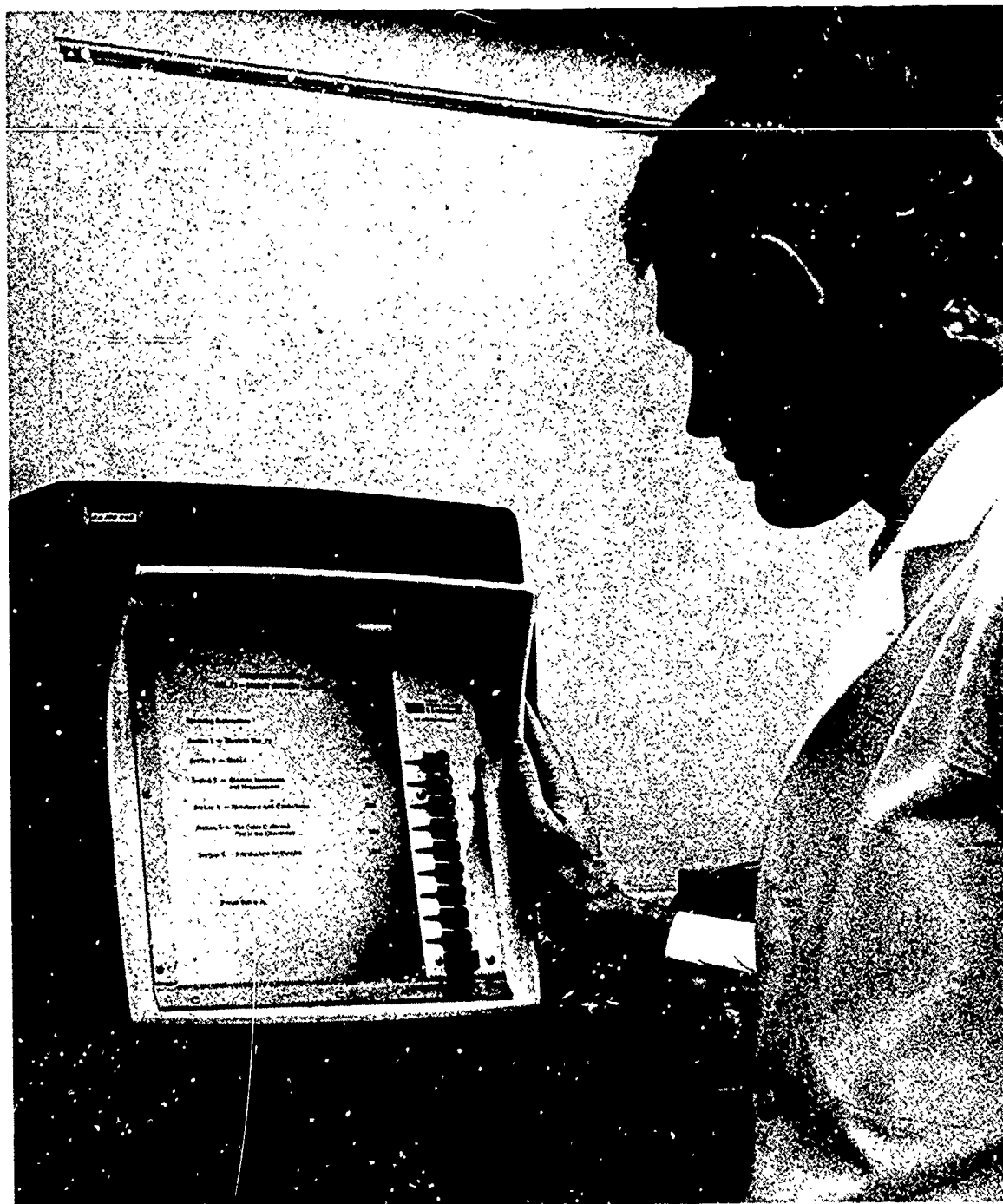

In figure 6 a student is shown operating the auto tutor teaching machine to learn the principles of basic electricity. This machine employs the use of a programmed instruction film which makes it possible for the student to learn this subject by selecting answers to questions that are asked in the instructional material when the buttons, located on the right side of the machine, are pressed. Whenever the student presses an incorrect answer to a question, he is then directed to the information he needs to answer the question correctly. He is then required to select the correct answer by depressing the proper button. This method of teaching has been found to be very successful in many areas of training.

The 50-item test was administered at the completion of the treatment period so that pretraining and posttraining estimates of each student's ability in basic electronics were obtained. A delayed criterion posttraining test was included as a part of the final examination. It was administered 12 weeks after the treatment period.

An additional measure of general electrical comprehension in passive or resistive circuitry was obtained from two problem solving types of quizzes administered during the period following the treatment. An extension test in electronic theory and circuit analysis of more advanced material was given at the conclusion of the term. This measure provided data for determining the upper limits of understanding for each student.

Micro-Precision Electronics

The need for training in basic electricity and electronics is important to the horologist as well as the micro-precision technician. Horology is moving steadily towards electric and electronic timepieces. In the micro-precision industry there is the same trend. In fact, Mr. A.N. McNeil of Minneapolis Honeywell at the University of Illinois National Chicago Conference said that it is suggested at Honeywell that the watch repairman employed there take courses in electronics. The reason given was simply that practically all the devices now made are not mechanical by themselves. There is a certain amount of electronics involved. It is believed that a study of basic electricity and electronics is extremely important and necessary to any program of study in this field.

In reference to the basic electricity and electronics courses in this program, it was felt by all concerned that there was not enough time devoted to these subjects and that the course should be presented over a two-term period of training. In electronics, as occurred in technical mathematics, the diverse background and ability of the students made it necessary to divide the class into upper and lower groups midway through the term. The class was divided so that the upper half came to the classroom on Tuesday and Thursday and the lower half came on Monday, Wednesday and Friday. All classes were two hours long. In this way, the classes were able to cover the same amount of material at the same time.

The main course, as a whole, went along very well. It was a pleasant surprise to see how far the majority of the students advanced in the short time allotted. A large variety of subjects was covered in a very short time and the students completed the course with a basic understanding of the material.

Technical Mathematics

Originally, the course in mathematics prepared for the Horological and Micro-Precision students was not designed to take into account the varying educational experiences and background of the students who were enrolled in the course. It was known that the class showed a large

range in the amount of mathematics background, but little was known of the actual calibre of work or the pace at which the individual students were capable of working. Within a few days, it became apparent that many class members were lacking badly in comprehension. A pretest in algebra and trigonometry, assigned to engineering freshmen at the University of Illinois was given, and the results showed a striking bimodal distribution of ability in the class. Since it was apparent that the general pace would have to be much slower than anticipated, it was decided to excuse four of the highest scoring students from further enrollment in the course, but to encourage their enrollment in more advanced regularly scheduled mathematics courses offered at the University. Within the remaining group, the work proceeded, using approximately the same sequence of topics as planned, but at a much slower pace and with the periodic addition of direct applicational references to the micro-precision laboratory work and the electronics to follow.

In order to interest and motivate the members of the poor mode of the class, for a few weeks class time was decreased for the more able class members and increased for those having trouble in maintaining common introductory periods on new material. The gap between the two groups widened, however, so that completely separate class meetings for the two groups were held for the duration of the project. The better performing class members completed all the work in algebra which was scheduled, while the poorer group covered most of these topics but at a much slower pace and with less depth per topic.

It was apparent very early that for several members of the poor group, mathematics did not seem to them to be relevant to their laboratory work, their main interest, and honest application on their part was at a minimum, showing spurts only prior to a quiz or at infrequent periods of faculty review of student progress. During the latter part of the spring term and all of the summer term, the better class met either two or three hours per week, while the poor group met at least four hours and sometimes five hours per week.

In general, it was felt that the lack of motivation apparent in some of the students for mathematics, was a direct result of their orientation toward watchmaking and the retail jewelry store and not being particularly interested in becoming micro-precision technicians as well. Furthermore, it is believed that greater motivation could possibly have been achieved if academic credit had been offered for the mathematics course.

During the summer term, some students expressed an interest in learning slide rule operation. It was apparent that there would be no class time available, so optional extra classes were held during free hours to provide this instruction. Approximately six hours of instruction were held on multiplication, division and combined operations, squares, cubes and roots, logarithms to the base 10, and decimal point manipulations. From four to seven persons attended these classes.

Technical Drafting

In micro-precision drawing (technical drafting) which was the last

class scheduled in the afternoon, it was felt that at this time of the day the students were somewhat fatigued and, therefore, not overly responsive. The students, however, gained a great deal of knowledge from the technical drafting course and the results of this training were clearly demonstrated in laboratory performance. It is imperative that a micro-precision technician have the knowledge and skills necessary to read, interpret and sketch instrumentation drawing.

Since there was a substantial amount of laboratory training involved in the research project, it is important that future research work be devoted to ways in which further integration and learning reinforcement can be achieved so that high motivation can be maintained.

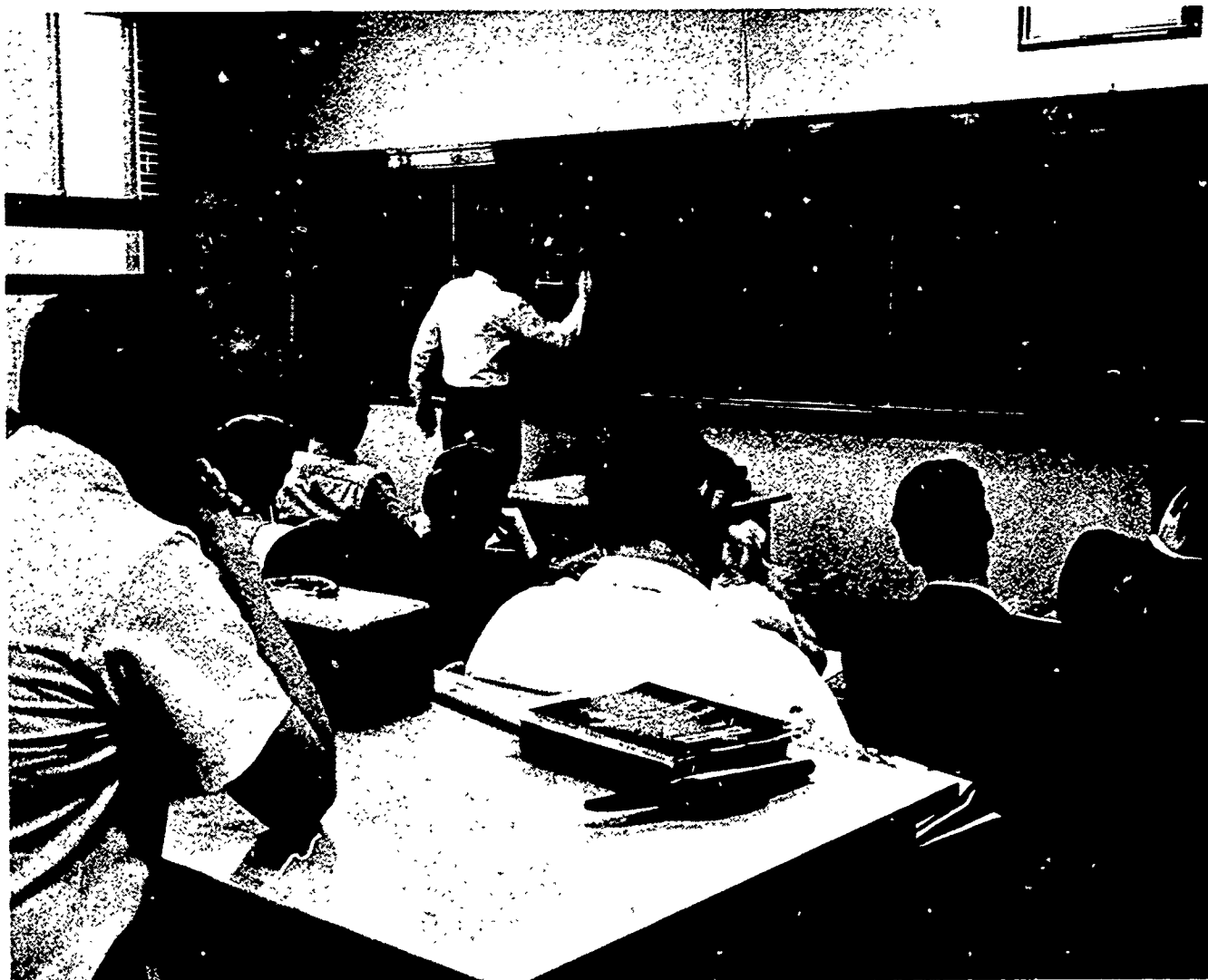

Figure 7 shows the Horological and Micro-Precision class during their mathematics class period. Classes from 1:00 to 5:00 p.m. daily consisted of technical mathematics, technical drafting, communications, applied economics, basic electricity and micro-precision electronics.

Applied Economics

This course was designed more for the horology-oriented student as it deals primarily with the management and operation of small businesses. This kind of study is most important to supplement any horology course as it establishes a sound basis for dealing with problems encountered in business enterprises today.

Communications

The study of communications is important to any technical program. It is needed for those who will enter industry as well as those who expect to remain in the horological field. This course of study which was especially prepared for the Horology and Micro-Precision training program was well received by the students as a whole.

New Proposed Curriculum

Many of the difficulties encountered in this training program in the related courses were a direct result of some of the students not seeing the relevance of certain subjects. This was apparent in cases where the students were horology-oriented and were not really interested in becoming micro-precision technicians as well. For this reason a new proposed curriculum has been developed to provide different related courses of study for the students who are oriented toward horology, from those provided for the horological and micro-precision students. (See Conclusions and Recommendations.)

Texts and References

For the Horological and Micro-Precision Project certain horological textbooks were purchased for use as a reference library for the students. Listed below are the textbooks that were made available exclusively for student use in this training program. There were several copies of each.

- Bulova, Joseph. School of Watchmaking
- DeCarle, Donald. Practical Watch Repairing.
- DeCarle, Donald. Watch and Clock Encyclopedia.
- Fried, Henry B. The Principles of Waterproofing Watches.
- Fried, Henry B. Watch Repairer's Manual.
- Higginbotham, C.T. Precision Time Measures.
- Humbert, B. Swiss Self Winding Watches.
- Jendritzki, H. The Swiss Watch Repair Manual.
- Jendritzki, H. Watch Adjustments.

Kelly, H.C. A Practical Course in Horology.

It was not necessary for the project to have a large selection of horological books as the University of Illinois Library was available to those students who wished to make use of it.

In addition, many trade publications were circulated to the students to help them keep abreast of new developments and general news in the industry. It is most important in a training program to have such materials available to the students. Students were encouraged to make use of these materials and in fact were many times required to study certain texts.

**HOROLOGY AND MICRO-PRECISION TECHNOLOGY
SEVEN-MONTH TRAINING PROGRAM**

THE CURRICULUM OUTLINE

| | Class Hours | Lab. Hours | Outside Study | Total Hours |
|---------------------------------|----------------|---------------|------------------|----------------|
| <u>First Term</u> | | | | |
| Horology Laboratory I | 5 | 15 | 3 | 23 |
| Technical Mathematics | 5 | 0 | 3 | 8 |
| Technical Drafting | 1 | 5 | 3 | 9 |
| Communications | 2 | 0 | 2 | 4 |
| Applied Economics | 3 | 0 | 4 | 7 |
| Basic Electricity (three weeks) | 3 | 0 | 2 | 5 |
| <u>Second Term</u> | | | | |
| Horology Laboratory II | 5 | 15 | 3 | 23 |
| Technical Mathematics | 5 | 0 | 3 | 8 |
| Micro-Precision Electronics | 4 | 2 | 4 | 10 |
| Communications | 2 | 0 | 2 | 4 |
| Applied Economics | 3 | 0 | 4 | 7 |

Brief Description of Courses

Horology Laboratory - First Term

A study and development of skills in conventional watch servicing and micro-precision machining. In addition, an introduction to meter instrumentation was given, to demonstrate that the transfer of horological skills can be easily made to various areas of instrumentation.

Horology Laboratory - Second Term

A study and development of advanced horological techniques and skills which included such phases of instrumentation as:

- (a) speed methods of servicing timepieces
- (b) electric and electronic timepieces
- (c) complicated watches

Technical Mathematics - First Term

A course in algebra presented on a typical technical institute level.

Technical Mathematics - Second Term

A course in basic trigonometry ideas, especially those pertinent

to other courses in the training program.

Technical Drafting - First Term

A course designed to introduce the students to drafting fundamentals involving principles of orthographic projection, theory of pictorial drawings, auxiliary projection, freehand sketching, basic dimensioning, fasteners, charts and diagrams, material specifications and working drawings.

Communications - First and Second Terms

A course emphasizing exercises in writing, speaking and listening. In addition, science and business communications were covered along with use of resource materials.

Applied Economics - First and Second Terms

A course designed to help the student learn what business is all about, view business in its entirety, a knowledge of business philosophy, and apply these concepts to practical situations. Generally these applications are in relation to case studies of small or medium size businesses.

Basic Electricity - First Term (Three weeks)

A short course in basic physical concepts of electrical circuits.

Micro-Precision Electronics - Second Term

A course of study in circuit analysis, electromagnetic transducers and electronic switching and shaping circuits with emphasis on performing control and measurement functions.

COURSE OUTLINES

HOROLOGY LABORATORY I
FIRST PHASE

Preparatory Horology

Hours Required

Class, 5; Laboratory, 15

Major Divisions

| | Hours | |
|---|-----------|-----------|
| | Class | Lab. |
| I. General Orientation and Preliminary Balance Wheel Work | 4 | 12 |
| II. Hairspring Work, First Phase | 4 | 12 |
| III. Cleaning and Oiling of Conventional Timepieces | 7 | 21 |
| IV. Repair and Adjustment of Timekeeping Elements | 5 | 15 |
| | <u>20</u> | <u>60</u> |

Division I. General Orientation and Preliminary Balance Wheel Work

A. Units of instruction

1. History of time
2. Proper handling and usage of tools
3. Posture and health habits while working
4. Basic terminology
5. Removing and replacing balance screws
6. Truing monometallic balance wheels in-the-flat
7. Heat and cold adjustment
8. Middle temperature error
9. Method of poising balance wheels
10. Procedure for removing weight from balance wheels
11. Making poising charts
12. Proper use of poising table
13. Dangers of over-poising
14. Method used to dynamically poise balance wheels
15. Proper use of the demagnetizer

B. Laboratory projects

1. Remove and replace balance screws
2. True monometallic balance wheels
3. Poise balance wheels

Division II. Hairspring Work, First Phase

A. Units of instruction

1. Straightening hairsprings in-the-round
2. Proper manipulation of tweezers
3. Methods of bumping hairsprings against center post to make

- corrective bends
- 4. Straightening basic out-of-flat bends
- 5. Forming overcoils
- 6. Use of overcoil tweezers
- 7. Purpose of overcoils
- 8. Concentric vibrations of the overcoil hairsprings
- 9. Eccentric behavior of flat hairsprings
- 10. Discussions of pendulum vibrations and other timekeeping elements, including the balance and hairspring units and tuning fork

B. Laboratory projects

- 1. Straighten hairsprings in-the-round
- 2. Straighten hairsprings in-the-flat
- 3. Form overcoils

Division III. Cleaning and Oiling of Conventional Timepieces

A. Units of instruction

- 1. Proper disassembly and assembly procedure
- 2. Nomenclature of parts
- 3. Function of each and every part
- 4. Cleaning procedure
- 5. Proper use of ultrasonic cleaning machines
- 6. Separation of parts in cleaning basket
- 7. Solution to use
- 8. Proper drying of parts
- 9. Oiling train bearings
- 10. Oiling escapement
- 11. Oiling balance jewels
- 12. Oiling mainspring
- 13. Oiling winding and setting mechanism
- 14. Proper use of timing machine
- 15. Proper regulation of a watch
- 16. Effect of regulator pins upon timekeeping qualities of a watch
- 17. Proper setting of regulator pins
- 18. Proper adjustment of hairspring between regulator pins
- 19. Raising or lowering stud to level hairspring

B. Laboratory projects

- 1. Disassemble and assemble movements using specially prepared instructional guide, giving step by step procedure (see Appendix A)
- 2. Clean watches with the use of ultrasonic cleaning machine
- 3. Oil movements and examine under microscope
- 4. Operate timing machines
- 5. Regulate watches
- 6. Adjust regulator pins
- 7. Adjust hairspring between the regulator pins
- 8. Raise or lower stud to level hairspring

Division IV. Repair and Adjustment of Timekeeping Elements

A. Units of instruction

1. Proper method of removing the hairspring from the balance wheel
2. Locating proper position to place the hairspring on the balance wheel for "beat"
3. Proper method of replacing the hairspring on the balance wheel (use of staking tool)
4. Staffing procedure
5. Types of staffs
6. Method of removing staffs from balance wheels
7. Proper use of the roller remover
8. Questions
9. Problems

B. Laboratory projects

1. Remove hairspring from balance wheels
2. Replace hairspring on balance wheels
3. Remove roller from balance staffs
4. Replace roller on balance staffs
5. Cut out staffs by turning off hubs
6. Cut out staffs by turning off rivets

Texts and References

- Abbott, H.G. Antique Watches and How to Establish Their Age.
- DeCarle, D. Practical Watch Repairing.
- DeCarle, D. Watch and Clock Encyclopedia.
- Fried, Henry B. The Watch Repairers Manual.
- Kelly, H.C. A Practical Course in Horology.
- Jendritzky, H. Swiss Watch Repairers Manual.
- Thisell, A.G. Science of Watch Repairing Simplified.

HOROLOGY LABORATORY I
SECOND PHASE

Micro-Precision Machining

Hours Required

Class, 5; Laboratory, 15

Major Divisions

| | Hours | |
|---|-------|-------|
| | Class | Lab. |
| I. Proper Use of the Watchmaker's Lathe | 1 | 3 |
| II. Measuring Instruments | 1 | 3 |
| III. Precision Lathe Turning | 3 | 9 |
| IV. Heat Treatment of Steel | 1 | 3 |
| V. Making a Parting Tool | 1 | 7 |
| VI. Turning Half Staffs | 1 | 7 |
| VII. Turning Bushings | 1 | 3 |
| | <hr/> | <hr/> |
| | 9 | 35 |

Division I. Proper Use of the Watchmaker's Lathe

A. Units of instruction

1. Preparing gravers
2. Care of oil stones
3. Sharpening gravers
4. Special finish for "cutting edge" of gravers
5. Test for sharpness of gravers
6. Use and care of gravers
7. Proper selection of chuck to fit material
8. Proper setting of T-rest
9. Proper use of tailstock
10. Proper lubrication of lathe
11. Coating of lathe to prevent rust

B. Laboratory projects

1. Sharpening square and Lozenge gravers with the use of the graver sharpener
2. Setting up lathe for turning

Division II. Measuring Instruments

A. Units of instruction

1. Proper care and use of a micrometer
2. Reading a micrometer
3. Proper care and use of the Boley gauge
4. Reading a Boley gauge
5. Proper care and use of a depth gauge
6. Reading a depth gauge

7. Questions
8. Problems

B. Laboratory projects

1. Measure various parts of a watch with a micrometer, Boley gauge and depth gauge
2. Cut steel rods into short lengths to be used in lathe turning

Division III. Precision Lathe Turning

A. Units of instruction

1. Turning square shoulders on steel
2. Turning undercuts
3. Turning bevels
4. Turning conical pivots
5. Turning half staffs
6. Questions
7. Problems
8. Review

B. Laboratory projects

1. Turn square shoulders on soft steel
2. Turn undercuts on soft steel
3. Turn conical pivots on soft steel
4. Turn half staffs on soft steel

Division IV. Heat Treatment of Steel

A. Units of instruction

1. Hardening
2. Annealing
3. Quenching
4. Tempering
5. Finishing
6. Questions
7. Problems
8. Examination

B. Laboratory projects

1. Harden pieces of drill rod
2. Temper pieces of drill rod
3. Finish drill rod
4. Anneal steel

Division V. Making a Parting Tool

A. Units of instruction

1. Making a drawing of the parting tool
2. Proper procedure to follow in making a parting tool
3. Proper hardening and tempering of parting tool

B. Laboratory projects

1. Make a parting tool to specified dimensions, harden and temper

Division VI. Turning Half Staffs

A. Units of instruction

1. Method of cutting for a smooth finish
2. Proper procedure for turning to specified measurements
3. Procedure to follow in obtaining high finish on balance pivots
4. Questions
5. Problems

B. Laboratory projects

1. Make a half staff of hardened and tempered drill rod to specified dimensions

Division VII. Turning Bushings

A. Units of instruction

1. Purpose of bushings in watches
2. Proper shape of bushings
3. Method of drilling
4. Procedure for obtaining a high finish
5. Questions
6. Problems

B. Laboratory projects

1. Machine bushings to various sizes and shapes and finish

Texts and References

DeCarle, D. The Watchmaker's Lathe and How to Use It.

Goodrich, W. The Watchmaker's Lathe.

HOROLOGY LABORATORY I
THIRD PHASE

Horology - Advanced Junior

Hours Required

Class, 5; Laboratory, 15

Major Divisions

| | Hours | |
|--|-----------|------------|
| | Class | Lab. |
| I. Escapement Work | 5 | 15 |
| II. Servicing Meters | 3 | 9 |
| III. Cleaning and Overhauling, First Phase | 4 | 12 |
| IV. Removing and Replacing Roller Jewels | 2 | 6 |
| V. Straightening Train Wheels | 1 | 3 |
| VI. Hairspring Work, Second Phase | 5 | 15 |
| VII. Adjusting the Escapement Within the Watch | 5 | 15 |
| VIII. Hairspring Work, Third Phase | 5 | 15 |
| IX. Micro-Precision Machining, Second Phase | 4 | 12 |
| X. Removing and Replacing Pallet Arbors | 1 | 3 |
| | <u>35</u> | <u>105</u> |

Division I. Escapement Work

A. Units of instruction

1. Escapement terminology
2. Function of the lever escapement
3. Method of matching stones
4. Setting drop lock
5. Inside and outside drop
6. Corner clearance
7. Corner test
8. Jewel pin shake
9. Guard clearance
10. Guard test
11. Hangup
12. Questions
13. Problems

B. Laboratory projects

1. Set the escapement model in accordance with the step by step procedure by following the specially prepared booklet (see Appendix B)
2. Find and correct errors in escapement settings
3. Reset and adjust the escapement model in which every adjustment is improperly set

Division II. Servicing Meters

A. Units of instruction

1. Proper procedure to disassemble and assemble voltmeters
2. Proper method of soldering and unsoldering of hairsprings at point of attachment
3. Nomenclature and function of each and every part
4. Calibrating and zeroing meters
5. Heat and cold factors concerning meters
6. Problems of lubricating meters
7. Questions
8. Problems
9. Examination

B. Laboratory projects

1. Disassemble and assemble voltmeter, permanent magnet moving coil type
2. Zero and calibrate meter (voltmeter)
3. Disassemble and assemble ammeter, permanent magnet moving coil type
4. Disassemble and assemble ohmmeter
5. Zero and calibrate meter (ohmmeter)

Division III. Cleaning and Overhauling, First Phase

A. Units of instruction

1. Basic 16-point checking procedure (see Appendix C)
2. Rating of watches
3. Questions
4. Problems

B. Laboratory projects

1. Overhaul of a timepiece using the 16-point checking procedure as a guide
2. Rate watches to positions

Division IV. Removing and Replacing Roller Jewels

A. Units of instruction

1. Proper handling of roller jewels
2. Cleaning procedure
3. Method of replacing roller jewels
4. Solving special problems regarding fit and measurement of jewels
5. Questions
6. Problems

B. Laboratory projects

1. Remove and replace single-roller roller jewels

2. Remove and replace double-roller roller jewels
3. Measure for proper size of roller jewel

Division V. Straightening Train Wheels

A. Units of instruction

1. Use of truing calipers in straightening bent train wheels
2. Procedure for handling wheel in straightening operation
3. Method of bending wheel to straighten it
4. Procedure to follow to straighten a wheel within the watch
5. Questions
6. Problems

B. Laboratory projects

1. Straighten train wheels in truing calipers
2. Straighten train wheels within the watch

Division VI. Hairspring Work, Second Phase

A. Units of instruction

1. Procedure for making a collet tool for hairsprings
2. Techniques for straightening a hairspring in-the-round
3. Method of correcting unusual out-of-round conditions of the hairspring
4. Method of removing tangles from a hairspring
5. The three basic techniques for straightening a hairspring in-the-flat
6. Speed methods of straightening a hairspring in-the-flat
7. Questions
8. Problems

B. Laboratory projects

1. Make a collet tool
2. Straighten hairsprings in-the-round
3. Remove tangles from hairspring
4. Straighten hairsprings in-the-flat
5. Straighten hairsprings in-the-flat using speed methods

Division VII. Adjusting the Escapement Within the Watch

A. Units of instruction

1. Proper method of matching stones
2. Setting drop lock
3. Setting inside and outside drop
4. Draw
5. Corner test
6. Jewel pin shake
7. Guard clearance

8. Guard test
9. Skip
10. Hangup
11. Method of adjusting stones
12. Proper use of pallet heater
13. Questions
14. Problems

B. Laboratory projects

1. Make all the checks in the escapement of an A. Schild 1525 movement
2. Reset the complete escapement of a watch
3. Reset an escapement in which the entire escapement has been thrown out of adjustment

Division VIII. Hairspring Work, Third Phase

A. Units of instruction

1. Removing and replacing the stud
2. Unpinning hairsprings at the collet
3. Repinning hairsprings at the collet
4. Proper alignment of hairspring around the collet
5. Leveling and centering the hairspring on the balance cock
6. Proper forming of the quadrant
7. Straightening of the hairspring within the watch
8. Forming new inner lip on hairspring and repinning hairspring to the collet
9. Questions
10. Problems

B. Laboratory projects

1. Remove and replace studs on hairsprings
2. Unpin and repin hairsprings at the collet
3. Level and center hairsprings at the collet
4. Level and center hairsprings on the balance cock
5. Adjust the quadrant of the hairsprings in reference to the regulator pins
6. Straighten hairsprings within the watch
7. Form new inner lips on hairsprings and repin hairsprings to the collet

Division IX. Micro-Precision Machining, Second Phase

A. Units of instruction

1. Proper method of using files in filing
2. Proper care of files
3. Proper procedure for making a collet-moving tool
4. Proper procedure to follow in altering the square on a stem (hand filing)
5. Method of altering balance staffs to fit properly

6. Review of staffing
7. Method of removing the balance staffs from the balance wheel

B. Laboratory projects

1. Make a collet-moving tool
2. Alter stems to specific measurements
3. Alter the rivet shoulder to fit the balance wheel
4. Alter balance staffs to fit roller tables
5. Complete the staffing operation in the watch
6. Remove balance staffs from balance wheels

Division X. Removing and Replacing Pallet Arbors

A. Units of instruction

1. Proper fit of arbor to fork
2. Proper position of arbor to fork
3. Method of removing old pallet arbors
4. Various types of pallet arbors
5. Questions
6. Problems

B. Laboratory projects

1. Remove and replace pallet arbors using staking tool
2. Remove pallet arbors using watchmaker's lathe

Texts and References

Barkus, H. Know the Escapement.

DeCarle, D. Practical Watch Adjusting and Springing.

Fried, Henry B. The Watch Escapement.

Fried, Henry B. The Watch Repairers Manual.

Gazeley, W.J. Clock and Watch Escapements.

Higginbotham, C.T. Precision Time Measures.

Jendritzky, H. Swiss Watch Repairers Manual.

Kelly, H.C. A Practical Course in Horology.

Kelly, H.C. Watch Repair.

Swinburne, J. The Mechanism of the Watch.

The Joseph Bulova School of Watchmaking Training Units.

Thisell, A.G. Science of Watch Repairing Simplified.

Wilkinson, T.J. The Lever Escapement.

HOROLOGY LABORATORY II
FIRST PHASE

Complete Work

Hours Required

Class, 5; Laboratory, 15

Major Divisions

| | Hours | |
|---|-----------|------------|
| | Class | Lab. |
| I. Friction Jeweling | 1 | 3 |
| II. Review of Hairspring Work | 2 | 6 |
| III. Photo-Milling | 1 | 3 |
| IV. Introduction of Speed Methods to Overhaul Watches | 5 | 15 |
| V. Sixteen Point Checking System | 15 | 45 |
| VI. Gear Cutting | 1 | 3 |
| VII. Replacing New Curb Pins and Guard Pins | 2 | 6 |
| VIII. Position Adjustment | 9 | 27 |
| IX. Complete Hairspring Work | 2 | 6 |
| | <u>38</u> | <u>114</u> |

Division I. Friction Jeweling

A. Units of instruction

1. Different types of jewels used in watches
2. Proper clearance of the pivot in the bearing holes of various jewels
3. Proper use of the friction jeweling tool
4. Proper setting of jewels for endshake
5. Proper relationship of balance jewel to cap jewel
6. Questions
7. Problems

B. Laboratory projects

1. Remove and replace balance jewels
2. Remove and replace cap jewels
3. Remove and replace train hole jewels

Division II. Review of Hairspring Work

A. Units of instruction

1. Method of straightening a hairspring in-the-round
2. Method of straightening a hairspring in-the-flat
3. Removing tangles from hairsprings
4. Leveling and centering of hairsprings on the bridge
5. Manipulation of the hairspring within the watch itself
6. Adjusting the quadrant of the hairspring
7. Questions

8. Problems

B. Laboratory projects

1. Straighten a hairspring that was previously bent out of shape by the instructor
2. Straighten a hairspring and level and center it within a watch
3. Remove tangles from hairsprings

Division III. Photo-Milling

A. Units of instruction

1. Purpose of photo-milling
2. Techniques used in photo-milling
3. Advantages of photo-milling
4. Limitations of photo-milling

B. Laboratory projects

1. Follow through the procedure of photo-milling in the photo lab.

Division IV. Introduction of Speed Methods to Overhaul Watches

A. Units of instruction

1. Ultrasonic cleaning techniques used in the industry
2. Method of working with more than one movement at a time
3. Time saving factors of parts replacement
4. Questions
5. Problems

B. Laboratory projects

1. Disassemble, clean and overhaul movements, using speed methods
2. Time study on overhaul of movements

Division V. Sixteen Point Checking System

A. Units of instruction

1. Review of the sixteen checks to be made to insure the proper functioning of each and every part
2. Orientation of students to use of work sheets
3. Method of measuring for proper size roller jewel
4. Proper use of the roller jewel gauge
5. Questions
6. Problems
7. Examination

B. Laboratory projects

1. Disassemble, overhaul, clean, repair and lubricate movements

- following the sixteen point checking system
2. Measure the fork slot for proper fit of roller jewel

Division VI. Gear Cutting

A. Units of instruction

1. Type of gears
2. Calculating watch trains
3. Method of determining the number of teeth and cut
4. Selection of proper cutter
5. Setting up the milling attachment
6. Proper depth of cut
7. Obtaining proper finish to cut
8. Questions
9. Problems

B. Laboratory projects

1. Set-up equipment for gear cutting
2. Cut a few teeth in a wheel

Division VII. Replacing New Curb Pins and Guard Pins

A. Units of instruction

1. Proper procedure to follow in removing old or broken pin
2. Method used in inserting new pin
3. Proper procedure to follow in replacing a Swiss boot and regulator pin
4. Questions
5. Problems

B. Laboratory projects

1. Replace American-type curb pins
2. Replace Swiss-type curb pins
3. Replace guard pins

Division VIII. Position Adjustment

A. Units of instruction

1. Dynamic poise
2. Pinning point error
3. Change of motion from horizontal to vertical position
4. Law concerning frictional errors
5. Effect of the escapement on the timekeeping element
6. Effects of friction on the balance unit
7. Effect of curb pins on the isochronal rate
8. Method used to check mechanism for timing errors
9. Various beats of watches
10. Questions
11. Problems

B. Laboratory projects

1. Dynamically poise the balance unit with the use of the timing machine
2. Determine the positional error due to the pinning point of the hairspring
3. Adjust curb pins to alter the isochronal rate
4. Experiments with frictional errors in producing changes in rate
5. Rate every timepiece overhauled to positions and isochronism

Division IX. Complete Hairspring Work

A. Units of instruction

1. Procedure to follow in straightening hairsprings bent out-of-round and out-of-flat
2. Procedure to follow in straightening hairsprings bent out at the collet
3. Technique used for final inspection of hairspring in the watch
4. Questions
5. Problems

B. Laboratory projects

1. Straighten hairspring completely in every respect for final inspection

Texts and References

Fried, H. The Watch Repairers Manual.

Jendritzky, H. Watch Adjustment.

Lee and Lewis. Better Watchmaking Faster.

Purdom, C. Scientific Timing.

HOROLOGY LABORATORY II
SECOND PHASE

Shop Practice

Hours Required

Class, 5; Laboratory, 15

Major Divisions

| | Hours | |
|--|-----------|-----------|
| | Class | Lab. |
| I. Automatic Watches | 5 | 15 |
| II. Closing Holes | 2 | 6 |
| III. Removing Broken, Rusted or Improperly Fitted Screws | 3 | 9 |
| IV. Fitting Crowns | 1 | 3 |
| V. Small Job Repairs | 1 | 3 |
| VI. Waterproofing and Case Problems | 1 | 3 |
| VII. Ordering Parts - Review | 1 | 3 |
| VIII. Hands and Dial | 2 | 6 |
| IX. Electric and Electronic Watches | 3 | 9 |
| X. The Chronograph Mechanism | 1 | 3 |
| | <u>20</u> | <u>60</u> |

Division I. Automatic Watches

A. Units of instruction

1. Nomenclature of parts
2. Disassembly and assembly of automatic mechanisms
3. Principles of self-winding mechanisms
4. Automatic bumper springs
5. 360° wind automatic
6. One hundred percent automatics
7. Slipping bridle in barrel
8. Method of replacing rotor post or rotor bearing
9. Wind-up indicating mechanism
10. Questions
11. Problems

B. Laboratory projects

1. Overhaul A. Schild 1580 automatic watches
2. Overhaul A. Schild 1361 automatic watches
3. Overhaul ETA 2375 automatic watches

Division II. Closing Holes

A. Units of instruction

1. Method of determining the worn area of the hole
2. Selection of proper punches for closing holes
3. Proper use of the staking tool in closing holes

4. Method of reaming hole
5. Proper burnishing of hole to size
6. Method of removing burrs
7. Questions
8. Problems

B. Laboratory projects

1. Close holes in watch plates for final inspection
2. Close barrel holes in-the-round

Division III. Removing Broken, Rusted or Improperly Fitted Screws

A. Units of instruction

1. Proper use of the screw extracting tool
2. Method of driving out broken screws
3. Procedure for making a tap from a screw
4. Procedure for dissolving a screw by boiling in alum water
5. Procedure for removing broken ratchet screws
6. Reslotting a screw to extract it
7. Procedure to follow for loosening a rusted screw
8. Method of working out broken screws
9. Procedure for removing broken screws from balance wheel
10. Proper method of tightening eccentric studs
11. Questions
12. Problems

B. Laboratory projects

1. Drive out a broken screw with the use of a staking set
2. Make a tap from a screw
3. Dissolve a screw in alum water
4. Remove a broken ratchet screw
5. Remove a broken screw in a balance wheel
6. Reslot a screw to remove it

Division IV. Fitting Crowns

A. Units of instruction

1. Types of waterproof crowns
2. Proper size and fit of crown
3. Determining proper length of stem
4. Dustproof crowns
5. Dress crowns
6. Questions
7. Problems

B. Laboratory projects

1. Fit various crowns to watches

Division V. Small Job Repairs

A. Units of instruction

1. Jewelry polishing
2. Cleaning watch cases
3. Tightening bows
4. Proper fitting and selection of spring bars
5. Questions
6. Problems

B. Laboratory projects

1. Polish watch cases with the use of the buffing machine
2. Clean watch cases after buffing
3. Fit spring bars to cases

Division VI. Waterproofing and Case Problems

A. Units of instruction

1. Selecting the proper gasket for case
2. Proper fit of waterproof crown
3. Various types of waterproof cases
4. Method of testing waterproofness of cases
5. FTC regulations for water-resistant and waterproof watches
6. Proper fit of crystal to insure a good seal
7. Questions
8. Problems

B. Laboratory projects

1. Seal and test cases for waterproofness

Division VII. Ordering Parts - Review

A. Units of instruction

1. Proper use of catalog
2. Identifying watch
3. Proper method of ordering staff, stem, pallet arbors, roller tables, balance complete, hands and mainspring
4. Use of interchangeable parts
5. Staff variation, selection method
6. Shock jewel ordering
7. Automatic winding parts ordering
8. Chronograph parts ordering
9. Roller interchangeable parts guides
10. Questions
11. Problems

B. Laboratory projects

1. Fill out an order form for parts listed below for various calibres:

- (a) staff; (b) stem; (c) crown; (d) shock jewels;
- (e) automatic winding part; (f) mainspring; (g) hands

Division VII. Hands and Dial

A. Units of instruction

1. Proper method of cleaning dials
2. Proper selection of hour wheel washer
3. Proper fitting and adjustment of hands
4. Proper procedure to tighten cannon pinion
5. Proper dial train ratios
6. Procedure for centering dials
7. Proper procedure for tightening Swiss dial feet
8. Method of replacing a dial foot
9. Questions
10. Problems

B. Laboratory projects

1. Tighten Swiss dial feet
2. Center dials
3. Tighten cannon pinions
4. Loosen cannon pinions
5. Clean dials

Division IX. Electric and Electronic Watches

A. Units of instruction

1. Nomenclature of parts
2. Function of the Hamilton electric watch
3. Function of the Landeron electric watch
4. Function of a Timex electric watch
5. Function of the Accutron electronic watch
6. Questions
7. Problems

B. Laboratory projects

1. Work on electric and electronic watches

Division X. The Chronograph Mechanism

A. Units of instruction

1. Nomenclature of parts
2. Function and adjustment of chronograph parts
3. Various types of chronograph mechanisms
4. Questions
5. Problems

B. Laboratory projects

1. Adjust chronograph mechanism by moving eccentric stud
2. Check chronograph mechanism for proper functioning

Texts and References

DeCarle, D. Complicated Watches and Their Repair.

Fried, H. The Electric Watch Repair Manual.

Fried, H. The Principles of Waterproofing Watches.

Humbert, B. Swiss Self-Winding Watches.

Humbert, B. The Chronograph Watch.

Smith, W.O., Jr. The Esembl-O-Graf Library.

Smith, W.O., Jr. The Hamilton Electric Watch Repair Manual.

HOROLOGY LABORATORY II
THIRD PHASE

Practical Review

Hours Required

Class, 0; Laboratory, 7

Laboratory projects:

1. Repeat each phase of laboratory work which was covered in the entire program in preparation for AWI examination

Practical review hours: 70

BASIC ELECTRICITY

Hours Required

Class, 3; Laboratory, 0

Course Description

A three week long short course for introduction to, and preparation for, the course in electronics. It covers only the basic physical concepts of electrical circuits. Starting with the definition of charge, it goes into an explanation of Coulomb's Law and the quantities of voltage and current. After a discussion of Ohm's Law, the course concludes with basic circuit analysis derived from Kirchoff's Laws.

Major Divisions

| | Class Hours |
|--------------------------|-------------|
| I. Nature of Electricity | 3 |
| II. Ohm's Law | 3 |
| III. Kirchoff's Laws | 3 |

Division I. Nature of Electricity

A. Units of instruction

1. The atom
2. Charge
3. Coulomb's Law
4. Voltage
5. Current

Division II. Ohm's Law

A. Units of instruction

1. Energy loss through an element
2. Definition of resistance
3. Three ways of viewing Ohm's Law

a. $R = \frac{E}{I}$

b. $E = IR$

c. $I = \frac{E}{R}$

Division III. Kirchoff's Laws

A. Units of instruction

1. The electrical circuit
2. The series circuit
3. Kirchoff's Voltage Law
4. Ohm's Law in series circuits

5. The parallel circuit
6. Kirchoff's Current Law
7. Ohm's Law in parallel circuits

Texts and References

Babb. Resistive Circuits. (To be published by International Textbook Company)

Class Notes and Handouts.

MICRO-PRECISION ELECTRONICS

Hours Required

Class, 4; Laboratory, 2

Course Description

This course is designed to provide the student with enough basic knowledge of electronics to give him insight into any instrumentation problem he may confront. It is essentially a course in circuit analysis, electromagnetic transducers, and electronic switching and shaping circuits. The emphasis is on performing control and measurement functions.

The course begins with a detailed review of electric circuit analysis using resistive circuits. It then introduces the system approach to electric circuits, using simple circuits as building blocks to create complex circuit functions.

Input and output operations are then covered in the section on transducers. The course then finishes with coverage of electronic devices and circuits. In this section, the emphasis is on solid state circuitry, although some tube theory is covered as a comparison.

The laboratory portion of this course is handled on an exploratory basis. The student is given complete freedom to choose and design his experiment. The only requirement is that his investigation must pertain to the material currently being presented in the classroom.

Major Divisions

| | Hours | |
|-------------------------|-----------|-----------|
| | Class | Lab. |
| I. Circuit Analysis | 24 | 0 |
| II. Electronic Systems | 6 | 0 |
| III. Transducers | 18 | 6 |
| IV. Electronic Circuits | 18 | 18 |
| | <u>66</u> | <u>24</u> |

Division I. Circuit Analysis

A. Units of instruction

1. Nature of electricity

- a. voltage
- b. current

2. Ohm's Law

3. Kirchoff's Voltage Law

4. Kirchoff's Current Law

5. Simplification processes - equivalent circuits

Division II. Electronic Systems

A. Units of instruction

1. Function of electric circuits
2. Input-output functions

Division III. Transducers

A. Units of instruction

1. Magnetism
2. Electromagnetic transducers
3. Inductance
4. Capacitance and electrostatic transducers

B. Laboratory projects

1. Exponential response
2. Investigation of R-C circuits

Division IV. Electronic Circuits

A. Units of instruction

1. Circuit elements

- a. directional element
- b. valve - flow control
- c. controlled switch

2. Additional circuits

- a. switching circuits
 - (1) diode switch
 - (2) transistor switch
- b. pulse shaping circuits
- c. amplifying circuits
 - (1) small signal amplifier
 - (2) tuned amplifier

3. Applications of active circuits

- a. control
- b. timing
- c. information transmission

B. Laboratory projects

1. The diode

- a. investigation of diode action
 - b. the diode clipper
 - c. the diode clamper
 - d. diode logic circuits
2. The transistor switch
- a. single transistor circuits
 - (1) logic circuits
 - (2) sweep circuits
3. The transistor amplifier

TECHNICAL DRAFTING

Hours Required

Class, 1; Laboratory, 5

Course Description

This course is designed to introduce the student to drafting fundamentals involving principles of orthographic projection, theory of pictorial drawings, auxiliary projection, freehand sketching, basic dimensioning, fasteners, charts and diagrams, material specification and working drawings.

The course should be presented as a fundamental course in technical drafting, involving the various techniques of drafting, as found in the micro-precision industry. The course objectives are to develop the basic graphic skills of the student and to introduce the student to procedures, standards, specifications and terms used in industry.

Outside study should require one hour for every two hours in class and laboratory.

Major Divisions

| | Hours | |
|--|-------|------|
| | Class | Lab. |
| I. Fundamentals of Technical Drafting | 4 | 14 |
| II. Orthographic Projection and Freehand Sketching | 3 | 9 |
| III. Auxiliary Projection | 2 | 6 |
| IV. Pictorial Drawing | 2 | 8 |
| V. Sections | 2 | 6 |
| VI. Fasteners | 1 | 3 |
| VII. Charts and Diagrams | 1 | 3 |
| VIII. Dimensioning | 2 | 6 |
| IX. Working Drawings | 2 | 8 |

Division I. Fundamentals of Technical Drafting

A. Units of instruction

1. Lettering

- a. styles in lettering
- b. freehand techniques
- c. lettering pencils and guides

2. Drawing instruments

- a. use and care
- b. technique of drafting (pencil and ink)
- c. template for special symbols
- d. standard drawing sheet types and sizes

B. Laboratory projects

1. Freehand engineering style lettering exercises stressing weight, shape, style, slope, size and spacing
2. Lettering exercises using mechanical lettering guides
3. Make mechanical drawings involving elementary geometrical constructions. The accurate use of instruments with pencil and ink technique should be emphasized

Division II. Orthographic Projection and Freehand Sketching

A. Units of instruction

1. Theory of projection
 - a. types of projection
 - b. elements of projection
2. Orthographic projection
 - a. planes of projection
 - b. quadrants
 - c. position of object in relation to planes
 - d. selection of views
 - e. determination of visibility
 - f. projection of curved lines
 - g. layout of multiview drawing
 - h. relationship of lines and planes to principal co-ordinate planes
3. Freehand sketching
 - a. materials
 - b. technique
 - c. proportioning
 - d. multiview orthographic
 - e. isometric sketching
 - f. oblique sketching

B. Laboratory projects

1. Exercises on freehand sketching
2. Freehand sketching and scale drawings of simple objects, making multiview drawings from isometric or oblique drawings and vice versa
3. Exercises involving missing lines and views
4. Exercises on relationships of lines and planes to the principal co-ordinate planes

Division III. Auxiliary Projection

A. Units of instruction

1. Relation of auxiliary planes to principal planes and to the object (notation)

2. Construction of principal views by auxiliary
3. Points
 - a. relationship of points to each other
 - b. relationship of points to the principal planes
4. Lines
 - a. true length
 - b. bearing and slope
 - c. piercing points
 - d. angle between lines
 - e. intersecting and parallel lines
5. Planes
 - a. true size
 - b. intersection of two planes
 - c. angles between planes
 - d. distance between parallel planes
 - e. strike, dip, and outcrop
 - f. angles between lines and planes
6. Warped surfaces
 - a. hyperbolic paraboloid
 - b. helicoid

B. Laboratory projects

1. Construct auxiliary views to show the true shape of inclined surfaces of objects
2. Use auxiliary views to construct principal views
3. Practical problems involving the relationship between lines and planes
4. Draw a roof shaped as a hyperbolic paraboloid
5. Draw a chute in the shape of a helicoid

Division IV. Pictorial Drawing

A. Units of instruction

1. Isometric drawings
 - a. theory of projection including position of axis
 - b. isometrics of plane figures involving straight and curved lines
 - c. isometrics of solids involving straight and curved lines
 - d. isometrics of double curved surfaces
 - e. dimensioning isometric drawings
 - f. sectional views
 - g. advantages and disadvantages
2. Oblique drawing

- a. theory of projection
 - (1) cavalier
 - (2) cabinet
 - (3) general
- b. methods of constructing oblique drawings
- c. dimensioning oblique drawings
- d. sectioning oblique drawings
- e. advantages and disadvantages

B. Laboratory projects

- 1. Isometric drawings of machine parts
- 2. Oblique drawings of machine parts

Division V. Sections

A. Units of instruction

- 1. Types of sections
- 2. Drawing views of sections
 - a. section lining
 - b. hidden lines in sectioned views
 - c. visible lines behind the section plane
 - d. solid shafts and bars, bolts, pins, keys and screws in sections
 - e. spokes of wheels and thin webs
 - f. thin sections
 - g. conventional practice of showing odd numbers of holes, spokes and webs in cylindrical shaped objects

B. Laboratory projects

- 1. Draw the missing sectioned view for various types of sections
- 2. Determine the best section to pass for ease of reading various drawings

Division VI. Fasteners

A. Units of instruction

- 1. Screw threads
 - a. nomenclature
 - b. types
 - c. thread series
 - d. classes of thread fits
- 2. Representation of threads
 - a. conventional
 - b. simplified conventional

3. Representation of fasteners

- a. bolts and nuts
- b. screws
- c. keys
- d. splines
- e. springs

4. Specification of threads and fasteners on drawings

B. Laboratory projects

1. Conventional drawings of various threads and fasteners
2. Draw objects that involve conventional representation of fasteners applicable to machine design

Division VII. Charts and Diagrams

A. Units of instruction

1. Use of charts in engineering practice
2. Classification of charts
3. Charts on various types of paper

- a. rectangular
- b. semi-logarithmic
- c. logarithmic

4. Mechanics of chart drawing

- a. selection of axis
- b. choice of scales
- c. marking coordinates
- d. representation of points
- e. drawing the curves
- f. titles

B. Laboratory projects

1. Drawing of various types of charts with primary emphasis on line charts

- a. plane curves
- b. bar charts
- c. flow charts

2. Interpretation of various types of charts

- a. plane curves
- b. bar charts
- c. flow charts
- d. pie diagram
- e. trilinear charts

Division VIII. Dimensioning

A. Units of instruction

1. General dimensioning

- a. technique of how to dimension
- b. where to place dimensions on drawing
- c. what to dimension
- d. size dimensioning
- e. location dimensioning
- f. dimensioning parts produced by standard shop operations
- g. notes and symbols

2. Shop terms and processes

- a. castings
- b. forgings
- c. machine shop processes

3. Material specification

4. Tolerancing

- a. definition of terms
- b. classes of fit
- c. computing tolerance dimensions

B. Laboratory projects

1. Dimensioning of simple machine parts with views furnished to students
2. Dimensioning of more complex machine parts involving tolerance, fasteners, finished surfaces, decimal dimensioning, et cetera

Division IX. Working Drawings

A. Units of instruction

1. Working drawings

- a. requirements for a complete working drawing
- b. title block
- c. drawing revision

2. Assembly drawing

- a. type
- b. dimensioning and sectioning practices
- c. listing of parts

B. Laboratory projects

1. Make complete working drawings of a machine

2. Make assembly drawings from working drawings

Texts and References

Arnold, J.N. Introductory Graphics.

Douglas, C.E., and Hoag, A.L. Descriptive Geometry.

French, T.E., and Vierck, C.J. Graphic Science.

Grant H.D. Practical Descriptive Geometry.

Hoelscher, R.P., Springer, C.H., and Dobrovlny, J.S. Basic Drawing for Engineering Technology.

Pare, E.G. Engineering Drawing.

Pare, E.G., Loving, R.O., and Hill, J.L. Descriptive Geometry.

Spencer, H.C. Basic Technical Drawing.

Zozzore, F. Engineering Drawing.

Many of the texts listed above have problem books to accompany them.

TECHNICAL MATHEMATICS
FIRST TERM

Hours Required

Class, 5; Laboratory, 0

Course Description

The plan for the two-term mathematics course was to present a typical technical institute level course in algebra followed by elementary trigonometry. Based on the better mathematics background of some of the participants, it was thought possible that in the latter portion of the summer term a few people might also do some introductory work in analytic geometry and learn the nature of differential calculus.

The first term class was scheduled to meet for approximately 14 weeks. It was planned to give appropriate quizzes at roughly two-week intervals. The plan for the first term had topics scheduled as follows:

Major Divisions

| | Class Hours |
|-----------------------------|-------------|
| I. Algebraic Operations | 30 |
| II. Equations | 18 |
| III. Exponents and Radicals | 10 |
| IV. Logarithms | 6 |

Division I. Algebraic Operations

A. Units of instruction

1. Terminology, definitions, review of numbers, quantities, expressions
2. Associative, distributive, commutative laws
3. Manipulation of algebraic expressions, monomials, polynomials, addition and subtraction, multiplication and division
4. Exponential laws
5. Special products
6. Factoring
 - a. common factor, grouping
 - b. squares; difference between squares
 - c. general quadratics
 - d. completing the square
 - e. the quadratic formula
7. Fractions; with monomials; with polynomials
 - a. simplification
 - b. multiplication or division
 - c. addition or subtraction
 - d. complex fractions

8. Variation and proportion

- a. ratio and proportion
- b. direct or inverse

Division II. Equations

A. Units of instruction

1. Meaning of an equation
2. Simple equations with one unknown; substitution and solution
3. Graphical representation; graphical solution
4. Simple equations with two unknowns; simultaneous equations
5. Solution by substitution or elimination
6. Graphical representation; graphical solution
7. Introduction to various types of equations
 - a. quadratic, cubic quartic
 - b. sample graphical representations
8. Formula or equation re-arrangement
 - a. substitution and solution for different variables
9. Applied problems; manipulation and solution
 - a. structuring equations for simple word problems

Division III. Exponents and Radicals

A. Units of instruction

1. Definitions; basic exponential laws
2. Exponents and radicals
 - a. fractional, zero, or negative
 - b. extension of basic laws
 - c. equalities and transformations
3. Radicals
 - a. removing or adding factors
 - b. reducing the index
 - c. rationalizing the denominator
 - d. reduction to simplest form

Division IV. Logarithms

A. Units of instruction

1. Definitions; characteristic, mantissa
2. Rules, use of tables for logs to base 10
3. Antilogarithms; use of tables

4. Computation with logarithms
 - a. multiplication or division
 - b. finding powers or roots
5. Other bases; relationship to other exponential and radical expressions
 - a. simple problems; equalities
 - b. conversions to equivalent expressions

Texts and References

Andres, Meiser, and Reingold. Basic Mathematics for Scientists and Engineers.

Dolciani, Berman, Freilich. Modern Algebra I.

Lehmann. College Algebra.

Plack, R.J. Technical Mathematics with Calculus.

Rider. College Algebra.

During the summer term, students expressed an interest in learning slide rule operation. It was apparent there would be no class time available, so optional extra classes were held during free hours to provide this instruction. Approximately six hours of instruction were held on multiplication, division and combined operations; square, cubes and roots; logarithms to the base 10; and decimal point manipulations. From four to seven persons attended these classes.

TECHNICAL MATHEMATICS
SECOND TERM

Hours Required

Class, 5; Laboratory, 0

Course Description

The course was designed to include basic trigonometric ideas and especially those pertinent to other courses in the project. Since the first term course actually was expanded in time to cover over half of the second term, the second term material was markedly reduced.

Major Divisions

I. Introductory Trigonometry

Class Hours
15

Division I. Introductory Trigonometry

A. Units of instruction

1. Definitions
2. Radian measure, degree measure; conversions
3. Angles, quadrants, terminology
4. Definition of trig functions; manipulations
5. Use of trig tables
6. Solution of right triangles; relationships
7. Applications; vectors and components; forces and velocities
8. Oblique triangles
9. Law of sines; law of cosines

Texts and References

Andres, Meiser, and Reingold. Basic Mathematics for Scientists and Engineers.

Dolciani, Berman, and Wooton. Modern Algebra and Trigonometry, Book II.

Plack, R.J. Technical Mathematics with Calculus.

APPLIED ECONOMICS

Hours Required

Class, 3; Laboratory, 0

Course Description

The Applied Economics course is designed to help the students learn what business is all about, view business in its entirety, gain knowledge of business philosophy, and apply these concepts to practical situations. Generally, these applications will be to the case studies of small or medium size businesses. Emphasis is placed on the management and operation of such business enterprises and where possible, cases, problems, and examples are oriented to the watchmaking, jewelry, and closely allied areas. Although the text provides a good overview of modern business, it is perhaps, too general in its coverage of certain basic business activities and operations. For this reason, and for their importance in retail management, such topics as inventory techniques, depreciation, compound interest, and others are introduced throughout the course.

Major Divisions

| | Class Hours |
|--|-------------|
| I. Introduction | 3 |
| II. Fundamental Aspects of Business | 8 |
| III. Business Ownership and Administration | 9 |
| IV. Marketing | 21 |
| V. Financing | 14 |
| VI. Manufacturing | 14 |
| VII. Human Relations | 8 |

Division I. Introduction

A. Units of instruction

1. Objectives of course
2. Requirements and mechanics of course
3. Business problem solving

Division II. Fundamental Aspects of Business

A. Units of instruction

1. The subject of business
2. People in business
3. Personnel programs and practices

Division III. Business Ownership and Administration

A. Units of instruction

1. Business ownership
2. Management of business

3. Business organization structures

Division IV. Marketing

A. Units of instruction

1. Marketing in modern business
2. Considerations in pricing
3. Selling
4. Research in marketing
5. Advertising and sales promoting
6. Worldwide marketing

Division V. Financing

A. Units of instruction

1. Business financing
2. Financial institutions
3. Security exchanges
4. Financial problems and statements
5. Compound interest
6. Capital budgeting

Division VI. Manufacturing

A. Units of instruction

1. Physical aspects of production
2. Inventories
3. Maximum order quantities
4. Depreciation

Division VII. Human Relations

A. Units of instruction

1. Fundamental concepts
2. Purposes and goals of human relations
3. Development of human relations
4. Popular misconceptions

Texts and References

Business Week Magazine.

Cases in Marketing Strategy.

Costellow and Zalkind. Psychology in Administration.

Goodell. Student Workbook for Introduction to Business.

Jucius and Terry. Introduction to Business.

Luck, D.J., Wales, H.G., and Taylor, D.L. Marketing Research.
Nation's Business Magazine.

Wales, H.G., Engel, J.F., and Warshaw, M. Promotional Strategy.

Zalesnik and Moment. The Dynamics of Interpersonal Behavior.

COMMUNICATIONS SKILLS

Hours Required

Class, 2; Laboratory, 0

Course Description

The course emphasized exercises in writing, speaking and listening.

The instructional material should be arranged primarily to help the student improve skills where common weaknesses are found.

Major Divisions

| | Class Hours |
|---|-------------|
| I. Science and Business Communications | 10 |
| II. Use of Resource Material | 6 |
| III. Composition and Means of Communicating | 20 |
| IV. Grammar and Structure in Communicating | 8 |
| V. Vocabulary | 8 |
| | <hr/> 52 |

Division I. Science and Business Communications

A. Units of instruction

1. History of measurement and time
2. History of science and micro-precision work
3. Industrial Revolution and mass production of time pieces
 - a. patents, copyrights
 - b. standard of living
 - c. capitalism
 - d. automation

Division II. Use of Resource Material

A. Units of instruction

1. Library skills
 - a. parts of a book
 - b. how to locate books
 - (1) card catalog
 - (2) location
 - (3) simplified Dewey Decimal System
 - (4) reference
2. Dictionaries
 - a. encyclopedias, periodicals
 - b. biographical reference books

3. Methods used in science and micro-precision problems
 - a. how information is obtained, recorded and presented
 - b. how to carry on investigations in micro-precision and watch technology
4. Other reference sources
 - a. technical manuals
 - b. periodicals

Division II. Use of Resource Material (Exercise)

A. Units of instruction

1. Encyclopedias
2. Atlases
3. Technical guides
4. Other

Division III. Composition and Means of Communicating

A. Units of instruction

1. Introduction
 - a. why study English?
 - b. the importance
 - c. precision in science and communications
2. Writing effective paragraphs
 - a. the big idea (topic, sentence)
 - b. unity
3. Writing compositions
 - a. outlining
 - b. precise writing
 - c. paraphrasing
4. Writing the technical report
 - a. letters
 - b. the informal report
 - c. the progress report
 - d. the information report
 - e. the inspection (trip) report
 - f. the problem-solution report
5. Mechanics
 - a. punctuation - period, question mark, and exclamation

- point, comma, semi-colan, colan, dash, parenthesis,
apostrophe
- b. capitalization

Division IV. Grammar and Structure in Communicating

A. Units of instruction

1. Coherence in communication
2. Practical language activities
3. Practise writing skills
4. Essential knowledge of words - words in order and word relationships

Division V. Vocabulary

A. Units of instruction.

1. Word lists taken from the various technical areas
2. Non-technical words to expand students' vocabulary
3. Words studied using many approaches
4. Systematic approach to word attack
5. Recognition
 - a. context
 - b. compound words
 - c. auditory-phonics
 - d. structural
 - e. "is"
 - f. plurals
 - g. hyphened words
 - h. abbreviations
6. Speech units (introduction)
 - a. enjoyment
 - b. enrichment
 - c. companionship
 - d. story telling
 - e. good impressions on others
7. Sales and technology (communicating ideas)
 - a. explanations
 - b. descriptions
 - c. instructions
 - d. suggestions
 - e. opinions
 - f. importance of listening
8. Pronunciation
 - a. American speech sounds

- b. authority
 - c. deviations
 - d. individual speech sounds; diacritical markings; phonetic symbols (I.P.A.): analysis of formation
9. Preparing a speech (choosing a subject)
- a. personal interest
 - b. listener interest
 - c. choosing a central theme
 - d. choosing a purpose - sentence
 - e. selecting two or three main points
- (1) orders - time, space, classification, causes and effects, problem-solution, make straightaway statements
 - (2) using specific and interesting material to support points - illustrations, comparisons and contrasts, facts and figures, humor and discretion, concrete words, colorful words, omission of superfluous words
 - (3) outlining - purpose-sentence, introduction, get attention and good will, orient listeners
 - (4) body - limit to two or three main points, organize to some thought pattern, consider audiences' attitude

Texts and References

Blumenthal, J.C. English 2600.

Crouch, W. George, Zetler, Robert L. A Guide to Technical Writing.

Gaum, Carl G., Graves, Harold F., and Hofman, Lyne S.S. Report Writing.

Richardson, Ralph A., and Brown, C.A. How to Organize and Write.

Shuman, John T. English for Vocational and Technical Schools.

Tracy, R.C., and Jennings, H.L. Handbook for Technical Writers.

Warriner, John E. Handbook of English: Book II.

RESULTS AND FINDINGS

Following is a list of results and findings which the research staff consider to be of importance to the field of horology and micro-precision technology. It is not suggested that these findings have been demonstrated empirically to be the result of the activities listed in each finding; rather, the staff recognizes that the Hawthorne Effect and other variables may confound the results. Nevertheless, the results and findings listed herein should prove to be of value to the field and lead to more controlled experimentation and hopefully continued attempts at innovation.

1. Careful consideration was given to the student attention span and the methods by which students could be motivated in the horology laboratory sessions. The following activities were incorporated in an effort to enhance student motivation.

- (a) The training activities were scheduled in a manner that would give students an opportunity to perform early in the course many of the tasks that are usually reserved to later stages of training. For instance, in the first few weeks of training, students were given movements to disassemble and assemble, and engaged in hairspring work, forming overcoils, and similar activities.
- (b) Student attention span was considered in determining the length of time to be spent on a single project. For example, difficult topics often generate short attention spans for students; hence, in instances in which topics of this type were covered, relatively short training periods were incorporated in the daily 4-hour teaching schedule by alternating the topics that were considered difficult with those that seemed to be less difficult for the trainees.
- (c) The objective of instruction was explained to the students beforehand.
- (d) Students were involved in training sessions that would demonstrate the transfer of horological skills to instrumentation.
- (e) Students were treated as adults by the instructors and were encouraged to explore various areas of training on their own time and resources.
- (f) As a means of generating a professional atmosphere in the laboratory, students were required to wear ties and white coats.

2. Educational techniques which involved group instruction were tried in the educational process in the laboratory work. They covered the following activities:

- (a) All students were studying the same phase of instruction at any moment of time in a given course. This frequently made it

possible for the students to study together and to help one another.

- (b) Lectures, followed by question and answer sessions, could be given to the entire class.
- (c) Demonstrations of the techniques involved in developing a given skill in the micro-precision and horological work were planned in a manner that would use a student to do the demonstrating, which created a lively and interesting atmosphere.
- (d) Any problems that developed were brought to the attention of the entire group and the solutions to these problems were provided through discussions growing out of the entire class.

3. Emphasis was given to training techniques that would help the students develop methods which would provide speed and accuracy in their work. A number of activities helped the students attain this objective:

- (a) Speed methods were taught, such as having the student work on more than one movement at a time, utilizing the tools he had in every possible way before picking up the next tool, developing a touch system for selecting tools, and similar techniques.
- (b) Working habits were established by habitual sequence of performance.
- (c) Students were taught to maintain their tools in good condition and in proper location on or in the bench at all times.
- (d) Students were required to keep benches clean and orderly.
- (e) Good lighting and other proper physical conditions were given adequate attention in order to provide the appropriate working environment.

4. Based on the experience of a seven-month training session it was felt that best results can be achieved in the laboratory class where there is a maximum of 15 students per instructor. This is extremely important because individual instruction is often necessary.

- (a) The order in which the topics were presented was given consideration and an entirely new curriculum was designed with this as a prime educational consideration.
- (b) Specially prepared programmed instructional material (see Appendixes A and B) was felt to be of assistance in carrying out various teaching situations due to the fact that it saves time for the student and it provides a change from the customary teaching methods.
- (c) It was found that the use of a work sheet (see Appendix C) is extremely important for every phase of laboratory work. It can

be used as a control to determine the student's progress.

- (d) Extra outside assignments provided an implementation for the students' educational experiences that helped to give breadth and depth to the content of each course in the program.
- (e) The related subjects helped to reinforce the work that the students did in the more advanced laboratory sessions.

5. By training students in horology, electricity, electronics, mathematics, drafting, business administration, and other subjects, a coalescence or integration of the educational experience of the student was planned so as to give emphasis to the occupational areas of horology and micro-precision technology.

- (a) Horology is the core laboratory experience for micro-precision training.
- (b) An entirely new course of study has been outlined that will need further exploration in this emerging field of vocational education.
- (c) The work done thus far in the program set forth here seems to indicate that a course in horology should require not less than nine months or one academic year. The length of the training program was limited to seven months because of the delay in Government approval of the contract and the fact that all of the preparation of materials and the training had to be done within a 12-month period. As a result, this gave students a heavy work load (36 class hours per week plus outside preparation) and did not give time for them to develop quite enough skill and confidence to prepare adequately for the American Watchmakers Institute Certified Master Watchmaker Examination, which was used as a longitudinal test. It also did not provide enough time to cover in depth all of the material in the electronics course.
- (d) A complete course in horology and micro-precision technology training should require 18 months or two academic years of training.

6. The experience gained in training and placing the students as horologists and micro-precision technicians confirms the experience of other schools which are engaged in similar training, namely, that there is a substantial need for additional personnel in this field.

- (a) Many individuals who are trained for micro-precision work will be in a position to elect the field of their major interest (horology and/or related micro-precision technology) for their life's work.
- (b) Information obtained from questionnaires and informal conversations with staff members of horological schools has indicated

an interest in exploring and developing further educational possibilities in similar training programs and in making use of the materials which have been prepared, along with course outlines and any other related materials that would help them in their present training programs.

- (c) The Horological and Micro-Precision Project has made it possible to prepare a detailed chronological record of horological laboratory sessions that will be extremely valuable to anyone training in these fields.
- (d) A physical fitness program initiated in connection with this project needs further attention in order to maintain good health for the trainees who select this field of vocational work as a life's work.

7. A variety of tests were used to measure the aptitude of the students for horological and micro-precision training, and the skills which they were able to develop.

- (a) Immediately upon enrolling in the course all students were given the GATB series and the Minnesota Vocational Inventory tests as administered in a research project of the U.S. Employment Service, designed for the program and for similar training programs in the United States.
- (b) Various tests appropriate to the individual courses were used. In the basic electronics course, for instance, test scores received on the immediate and delayed post-training achievement tests, the two term quizzes, and the extension test were used to determine the measures of achievement. As expected, the tests were highly intercorrelated because they measured similar aspects of the same body of knowledge. None of the statistical tests of achievement showed any significant differences between the two groups of students, one of which was trained with conventional methods and the other trained with the aid of programmed instruction and other innovative teaching devices. Nevertheless, continued and more extensive experimentation seems to be in order.

8. Many of the students accepted for this particular program were horology-oriented, because of family background or for similar reasons. Future programs of this type may wish to give attention to means by which this bias can be controlled.

Further Investigation Needed

1. There is a real need for more programmed instruction material, audio-visual aids, demonstration equipment, individual visual aids, stations for teachers, closed circuit televisions, and monographs on selected topics, covering many advanced aspects of this work. (See results from questionnaires, Appendix H).

2. Further experimentation with new developments and techniques is needed. For example, an experiment made with a new bench top indicates that the flat surface of the ordinary horologist's bench needs further experimentation in order to determine the exact design and formation of a more advantageous working surface for the horologist and micro-precision technician.
3. The proposed program in horology and micro-precision technology which is outlined in this report must be put into an experimental design so that further explorations can be made into educational problems outlined in this report. (See Proposed Curriculum Outlines, pages 83, 84 and 85.)
4. Further investigation of industry's needs is most vital in order to obtain a broader picture of what the student will be required to do on-the-job after training. A follow-up of graduates in such a training program is an important aspect of this type of investigation. A formal program of investigation needs to be carried out to provide feedback that can be utilized to upgrade and design additional educational materials for horological and micro-precision personnel.
5. The public needs to be made aware of the new field of micro-precision technology and the part the horologist plays in this vocational field.
6. Summer institutes for instructors are needed in order to acquaint them with the various techniques of training that have been developed and the areas of related study that need further exploration in this type of training.
7. Further investigation is needed in the area of recruitment methods and selection criteria for students in horology and micro-precision courses in order to more accurately determine the likelihood of successful completion of a training program for these students.
8. Investigation into ways in which variations in French, German, English, and American terminology can be standardized is needed.
9. Studies on the design and use of various types of tests and examinations would be helpful in establishing performance levels of both students and employed workers in horological and micro-precision work.

CONCLUSIONS AND RECOMMENDATIONS

Through research on instruction in horology and micro-precision technology, a new and unusual approach has been developed to train people for this field. It was found, however, that the seven-month training program, conducted at the University of Illinois, did not allow for enough time for the students to master certain advanced aspects of the training. Hence, a truly comprehensive horology course would require additional time. In addition, a horological and micro-precision training program probably would require a total of 18 months of training. It is suggested by this study that the students who are interested only in horology should not be required to take the other academic and technical subjects necessary for micro-precision technology. It is believed that a division should take place after the first quarter of training. In the second quarter of training, the horology oriented students should then be required to take courses related to the field of horology, such as: business administration, jewelry repairing, jewelry manufacturing, et cetera, that will prepare him strictly for the watch-making and jewelry industry. However, the horology laboratory sessions should remain the same for both the horologist and micro-precision students as well, for the first three quarters of training.

The micro-precision students would, of course, continue with subjects related to this field of micro-precision technology, such as: mathematics, physics, electronics, et cetera. At the end of nine months of training, the course of instruction in the horological laboratory, as well as the related areas of training will be drastically different for the horologist, compared to the micro-precision technician.

A specially prepared proposed outline for a micro-precision curriculum, as well as a proposed outline for a horological curriculum is included with this report on page 84. The horological training program is one in which the student, upon completion of the course, requiring four quarters of training, would receive a certificate. Those completing the two-year or six quarter micro-precision training program would receive an associate's degree in this field. The need for horologists and micro-precision technicians is great. For the micro-precision technician, his training will serve him well in many diverse fields, in which the general trend is miniaturization. The educational processes required to train individuals in micro-precision technology is complicated by the fact that training must incorporate more than one area of scientific or engineering study. Students must master certain portions of mechanical, electrical and electronic engineering, with the theoretical and applied physics in order that they become acquainted with the principles, techniques and concepts of a micro-precision field.

In addition, micro-precision students must develop a high degree of dexterity and manipulative skills and become familiar with the unusual precise tolerances that are so demanding in this new line of work. Since micro-precision technicians are employed in such diverse areas of technology and often in very specialized situations, the properly trained technician must acquire certain skills and scientific knowledge and, in general, will be expected to perform in various job situations as follows:

1. To work under the supervision of engineering personnel and to apply talents in design or to plan modification to the extent of building the prototypes of various products.
2. To apply mathematical skills and give technical assistance to engineering personnel in micro-precision industries.
3. To prepare and interpret engineering drawings or sketches.
4. To work with small, intricate, precision mechanisms and understand the various facets of disassembly and assembly techniques.
5. To apply knowledge of mechanical principles, which include racks, cams, levers and gear trains.
6. To aid the engineer in planning use of materials in the development of new microminiature products.
7. To recommend specialized procedure for the repair and maintenance of complex equipment and components.
8. To utilize the technical know-how in machining micro parts and assemblies.
9. To trouble-shoot and apply developed abilities in diagnosing technical problems and making decisions to improve performance.
10. To handle and deal with diverse technical problems which may involve the application of several technical fields.
11. To analyze production plans in accordance with specialized techniques involved in micro-precision skills.

On the other hand, the specialized horologist will qualify to perform well in a variety of specialized areas, as:

1. Watch technician in a jewelry store.
2. Manager of a jewelry store.
3. Watch technician in a trade shop.
4. Manager of a trade shop.
5. Technician in various facets of the horological industries.
6. Watch material man in a material house.

It is expected that many horological schools will develop training programs in accordance with the new techniques developed through this research. In addition, it is expected that some of the more far-sighted horological institutions will engage not only in advanced training tech-

niques, but will move steadily towards training that will incorporate all the additional and necessary advanced training for the development of a true micro-precision course. In this report, every effort is made to provide pertinent data necessary to the formation of such training programs.

There is still, however, much that must be done in this field to tie together some of the loose ends. The results of this research provide a basis upon which further research and investigation can be developed. More programmed instruction materials are certainly needed and industry must be further investigated in order to keep the advanced aspects of micro-precision training in the laboratory in accordance with their ever-changing needs.

It should be noted that the method of programmed instruction used in the project can be used by most teachers in one way or another to generate further interest in classroom experimentation. Such experiments in teaching methods encourage further testing and analysis on the part of teachers. Additional experimentation may ultimately lead to further improvement in individualized instruction.

Granted that the amount of improvement shown by students receiving instruction via automatic programmed instructional devices was generally the same as that shown by students receiving conventional direct instruction. However, factors relating to per student costs and the availability of instructional staff for providing individual assistance has some significance.

In the new proposed curriculum outline, the advanced micro-precision laboratory work will include training on many types of meters, time fuse mechanisms, magnetic microphones and speakers, electro-mechanical instruments, photographic equipment, and building or constructing of prototypes of various mechanical, electrical and electronic devices. From the limited investigation that has been made in the industry, there is good reason to believe that these are the most desirable areas of laboratory training in which a student should be acquainted. Many persons from diverse industries who have examined the new proposed curriculum and who have had an opportunity to discuss the course content with the Horological and Micro-Precision staff, affirm without exception their approval of the course. In addition, they have indicated a desire to hire graduates of such a training program.

It is quite satisfying to those directly concerned with this project that Parkland College in Champaign, Illinois, started a course in horology and micro-precision technician training on January 2, 1968. The new proposed curriculum outline on pages 83, 84 and 85 are being followed in accordance with the University of Illinois Horological and Micro-Precision staff recommendations.

The seven-month course of training which was conducted at the University of Illinois will be extended over a period of nine months at Parkland College. Recommended changes in the curriculum will be followed, which is indicated in the new proposed curriculum. In this

respect, certain additional subjects have been included, and the horological laboratory work has been expanded to cover a greater area of micro-precision technology.

Overall, it is considered that the seven-month Horological and Micro-Precision training project, conducted at the University of Illinois from February 1 to August 31, 1967 was a success. In fact, it exceeded our best expectations, with one exception. The students did not perform quite as well as was hoped on the American Watchmakers Institute Certified Master Watchmaker Examination. However, there were many reasons for this which were more fully explained in an earlier section of this report.

The success of this project is indicated by the fact that not only all of the 3 graduates of the program were easily placed in good jobs using the new skills they had acquired, but each one of them could have been placed in four or five positions. Surely, this not only indicates the success of the training, but also indicates how badly technicians trained in this vital field are needed in the labor force today.

NEW PROPOSED CERTIFICATE HOROLOGICAL CURRICULUM

1st Quarter

| | <u>Class</u> | <u>Lab.</u> | <u>Credit</u> | <u>Contact</u> |
|-----------------------------|--------------|-------------|---------------|----------------|
| Horology Laboratory I | 3 | 12 | 6 | 15 |
| Technical Mathematics | 3 | 0 | 3 | 3 |
| Introduction to Electronics | 2 | 3 | 3 | 5 |
| Technical Drawing | 1 | 5 | 3 | 6 |
| Physical Education | 2 | 0 | 1 | 2 |
| | — | — | — | — |
| | 11 | 20 | 16 | 31 |

2nd Quarter

| | | | | |
|------------------------|----|----|----|----|
| Horology Laboratory II | 3 | 12 | 6 | 15 |
| Communications Skills | 3 | 0 | 3 | 3 |
| Jewelry Repairing | 1 | 5 | 3 | 6 |
| Business Management | 3 | 0 | 3 | 3 |
| | — | — | — | — |
| | 10 | 17 | 15 | 27 |

3rd Quarter

| | | | | |
|-------------------------|----|----|----|----|
| Horology Laboratory III | 3 | 12 | 6 | 15 |
| Communications Skills | 3 | 0 | 3 | 3 |
| Diamond Setting | 1 | 5 | 3 | 6 |
| Salesmanship | 3 | 0 | 3 | 3 |
| | — | — | — | — |
| | 10 | 17 | 15 | 27 |

4th Quarter

| | | | | |
|------------------------|---|----|--|----|
| Horology Laboratory IV | 5 | 15 | | 20 |
| Jewelry Engraving | 1 | 5 | | 6 |
| | — | — | | — |
| | 6 | 20 | | 26 |

NEW PROPOSED ASSOCIATE DEGREE MICRO-PRECISION CURRICULUM

1st Quarter

| | <u>Class</u> | <u>Lab.</u> | <u>Credit</u> | <u>Contact</u> |
|-----------------------------|--------------|-------------|---------------|----------------|
| Horology Laboratory I | 3 | 12 | 6 | 15 |
| Technical Mathematics I | 3 | 0 | 3 | 3 |
| Introduction to Electronics | 2 | 3 | 3 | 5 |
| Technical Drawing | 1 | 5 | 3 | 6 |
| Physical Education | 2 | 0 | 1 | 2 |
| | — | — | — | — |
| | 11 | 20 | 16 | 31 |

2nd Quarter

| | | | | |
|-----------------------------|----|----|----|----|
| Horology Laboratory II | 3 | 12 | 6 | 15 |
| Technical Mathematics II | 3 | 0 | 3 | 3 |
| Communications Skills | 3 | 0 | 3 | 3 |
| Introduction to Electronics | 2 | 3 | 4 | 5 |
| Physical Education | 2 | 0 | 1 | 2 |
| | — | — | — | — |
| | 13 | 15 | 17 | 28 |

3rd Quarter

| | | | | |
|--------------------------------------|----|----|----|----|
| Horology Laboratory III | 3 | 12 | 6 | 15 |
| Technical Mathematics III | 3 | 0 | 3 | 3 |
| Electrical Drafting | 1 | 3 | 2 | 4 |
| Applied Physics (Mechanics, Statics) | 3 | 3 | 4 | 6 |
| Communications Skills | 3 | 0 | 3 | 3 |
| Physical Education | 2 | 0 | 1 | 2 |
| | — | — | — | — |
| | 15 | 18 | 19 | 33 |

4th Quarter

| | | | | |
|---------------------------------------|----|----|----|----|
| Advanced Micro-Precision Laboratory I | 2 | 7 | 4 | 9 |
| Advanced Electronics I | 2 | 3 | 3 | 5 |
| Technical Mathematics IV | 3 | 0 | 3 | 3 |
| Economics | 3 | 0 | 3 | 3 |
| Physics | 3 | 3 | 4 | 6 |
| Technical Writing | 2 | 0 | 2 | 2 |
| Physical Education | 2 | 0 | 1 | 2 |
| | — | — | — | — |
| | 17 | 13 | 20 | 30 |

5th Quarter

| | <u>Class</u> | <u>Lab.</u> | <u>Credit</u> | <u>Contact</u> |
|--|--------------|-------------|---------------|----------------|
| Advanced Micro-Precision Laboratory II | 2 | 7 | 4 | 9 |
| Strength of Materials (Technical) | 3 | 3 | 4 | 6 |
| Survey of Social Science | 3 | 0 | 3 | 3 |
| Human Relations in the Work Situation | 3 | 0 | 3 | 3 |
| Materials of Industry | 2 | 3 | 3 | 5 |
| Physical Education | 2 | 0 | 1 | 2 |
| | — | — | — | — |
| | 15 | 13 | 18 | 28 |

6th Quarter

| | | | | |
|---------------------------|----|----|----|----|
| Precision Instrumentation | 2 | 7 | 4 | 9 |
| Advanced Electronics II | 3 | 3 | 4 | 6 |
| Survey of Social Science | 3 | 0 | 3 | 3 |
| Special Problems | 1 | 9 | 4 | 10 |
| Technical Elective | 1 | 6 | 3 | 7 |
| Physical Education | 2 | 0 | 1 | 2 |
| | — | — | — | — |
| | 12 | 25 | 19 | 37 |

**CHRONOLOGICAL RECORD OF HOROLOGICAL
AND MICRO-PRECISION LABORATORY SESSIONS**

This chronological record of Horological and Micro-Precision Laboratory Sessions includes a brief description of the material covered in each class period in horology and micro-precision work during the seven-months course.

This is by no means a complete report on all the material covered, but rather serves as an indication of the broad subjects covered and in some instances reports on the results which the students were able to produce. The horology instructor will be able to use this as an outline and fill in the related materials for each day's work.

CHRONOLOGICAL RECORD OF HOROLOGICAL LABORATORY SESSIONS

February 1, 1967

The Horological and Micro-Precision Technology Training Course was started on Wednesday, February 1, at 8:00 a.m. Dr. Hugh G. Wales, Project Supervisor, made a welcoming speech to the student body. At this point, Mr. William O. Smith, Jr. and Mr. A. Gray Lawrence, Instructors, spoke to the students on the definition of a watch, chronograph, calendar, self-winding watch, alarm watch, minute repeater mechanism, chronometer, horology, time, isochronism, and mean time rate. Each student was instructed to place the color identification tape on the drawers of his bench, in accordance with a drawing. The tools were then placed in each drawer as designated in the list of tools given to each student which indicated the position each tool should occupy in the bench. Each tool was held up by the instructors so that the student could identify it and then take his corresponding tool out of the box or wrapper and place it in his bench. It was pointed out to the students that by issuing a list designating the position each tool should occupy in the bench, we expected them to cooperate by keeping all bench tools in their proper positions at all times. This is important so that the instructors can, when necessary, work at any bench in the classroom and find the tools properly distributed throughout the bench; also the tools will be kept in the proper predetermined arrangement, which has been found to be most advantageous to the watchmaker. (A copy of the diagram and the list of tools is included - see Appendix F.) It took about two hours for the students to complete this task.

The students were then informed about the tools that should be placed on the top working surface of the bench and in the bench tray for normal working conditions. Consideration was also given to the height of the chair, and each student was required to adjust his chair so that when he was seated, his shoulder would be level with the top of the bench. Information was given pertaining to proper sitting posture with both feet on the floor and legs not crossed. Students were then informed about the proper handling and selection of screwdrivers and tweezers. The class was now ready to start the first assignment.

Balance wheels were passed out (one to each student). The size of the balance was about that used in a man's wrist watch. The students were told to remove each screw from the balance with the use of the balance screw holder and a demonstration was made on how this should be done. First, the screw could be loosened with the screwdriver (since all the screws were slotted), and then the balance screw holder was selected that would fit the contour of the screw head. The students were cautioned not to grip the screw too tightly with the balance screw holder to avoid marking the screw. After removing all the screws from the balance, and placing them in pithwood, the students were required to replace all the screws. Each balance wheel was carefully checked to see if any marks were made on the screws. To keep the screws from being damaged, the balance screw holding tool was not used to tighten screws. It was simply used to screw them in far enough so that a screwdriver

could then be used to make the last turn to tighten the screw head onto the balance rim. The main purpose here was to get the student acquainted with the small screws used in watches and to familiarize him with the handling of small parts. Balances were all checked, and any mark that appeared on any screw was pointed out to the student.

February 2

The students were given a new balance from which they were to remove all the screws and replace them without marking any of them. At this point each student was very careful to do this job without marring any of the screws on the balance. Having completed this project, the students were given a lecture on the proper procedure for truing a balance wheel, with the use of a truing caliper. Since this was the first time that the student had had any experience in using a truing caliper, full information was given on the following points: (1) the purpose of the indicator, (2) the proper method of placing the balance wheel in the truing caliper, (3) the proper handling of the truing caliper, insofar as how to hold it and how to align the indicator with the eye by bracing the head on the hand that is gripping the caliper, and (4) the small amount of light that should be seen between the indicator and the balance segment. The students were then required to place the balance wheel in the truing caliper, to set the indicator properly, and to have the instructors check this before proceeding. The students were told to check the balance wheel all the way around, to see if the light remained the same between the indicator and the balance wheel to determine if the balance wheel was true. Since these were new balances, the wheels were fairly close to being true. Next, the students were informed of the proper method of using tweezers to bend the balance wheel when truing it. The balance wheels were then bent out of flat by the instructors and the students were coached personally by the instructors on the proper method of re-truing the out-of-flat balance wheels.

February 3

The students were kept on truing balance wheels for the entire day. The results of their truing were excellent. Every student in the class did a very fine job, and the two balances that were issued to the students on February 1 and 2 were brought to perfect trueness in the flat.

The students were given a lecture on the heat and cold adjustments of compensating balances. In addition, full information was given pertaining to monometallic balances and the middle temperature error.

February 6 and 7

A lecture was given to the students on the proper method of statically poising a balance wheel. Information on this topic was fully explained as follows:

- (1) Condition of balance pivots
- (2) Cleanliness of the balance wheel and pivots

- (3) Cleanliness of the poising table
- (4) Level of the poising table
- (5) Adjusting of poising jaws so that the straight portion of the pivot will rest on the jaws
- (6) Purpose of tapping lightly on the bench or poising table to help the heavy spot on the balance to settle to the bottom
- (7) All the various methods of removing weight from the balance wheel

In performing the poising operation, each student was required to make a chart showing the location of the heavy spot on the balance wheel he was poising. The instructors checked each chart to see if it indicated the heavy spot correctly and then had the students remove a small amount of weight from the screw that was heavy. As soon as the balance wheel changed position, a new drawing was made on the chart to show the location of the new heavy spot on the balance, and again it was checked by the instructors. It was clearly pointed out to the student that the poising operation should be completed without the balance wheel moving over 90 degrees, that is, without weight being removed from the balance over a larger area than 90 degrees. A P-4 type tool was recommended for use in removing weight to poise these very inexpensive balance wheels. The students were given instruction on how this tool can be made from a standard screwdriver. It was pointed out that there are much more refined methods of removing weight from the balance wheel which we will use at a later date when we again are involved with poising balance wheels. The student was further informed as to the difficulty that can be encountered in poising due to a draft in the room and that the balance wheel and poising table may have to be shielded in such instances when performing this task. In addition, factors such as the possibility of magnetism in the balance wheel were explained to the students, so that they would be well-informed as to the problems involved when magnetism or static electricity is present in the balance or poising table. The student was required to poise the two balances which were originally issued to him on February 1 and 2.

February 8

Each student was issued a hairspring of the size used in a man's large wrist watch. A talk was given to the students concerning the method of truing a hairspring in the round, that is, making the proper bends and corrections, working from the center of the collet on out to the end of the hairspring. The hairsprings were then placed on a balance tack, and bends were made in the outside coil of each hairspring by the instructors. The students were shown how to make the corrections to bring this outer coil back into alignment with the other coil of the spring. (The students were permitted to use only one tweezer in this first phase of hairspring work. The hairspring was bumped against the center post of the balance tack to make the necessary bends to straighten the hairspring.) As the students completed this operation, bends were made farther in from the first coil. As each bend was corrected, the instructors made a new bend a little closer to the center of the hairspring. Each student removed the bends until he became

fairly proficient at making basic corrective manipulations of the hairspring to straighten it in the round.

February 9

The students were given another talk pertaining to the straightening of the hairspring, and this time the emphasis was placed on how to make corrective bends on a hairspring that was out of flat. The complete day was spent in having the students bring the hairspring back to level after it was bent out by the instructors. Taking a cup out of the hairspring was also covered in this phase of instruction.

February 10

The students were given a lecture on the proper method of forming a gradual rise overcoil hairspring. Cross lines were drawn on a piece of watch paper and the hairspring was placed in the proper position on the paper in relation to the $3/4$ of the outer coil that will be used in forming the overcoil. The position to grip the hairspring with the tweezers in order to make the first bend to raise the outer $3/4$ coil above the level of the hairspring was demonstrated. The second step that would level the quadrant was explained fully and the method for forming the overcoil in over the top of the hairspring, forming it inward to the 4th coil over the body of the spring itself, was fully covered. The students spent the full day in forming overcoils, and the quality of work that was turned out by the class in general was very good.

February 13

The students were given a talk on forming the Elgin type overcoil and the full day was spent in the forming of this particular type of overcoil. Also, information was given pertaining to the step-up overcoil which should be used on certain types of overcoils. The day was spent with the students working and forming this particular type of overcoil.

February 14

Students were given a talk on the purpose of an overcoil, the difference in the eccentric vibrations of a flat hairspring, and the concentric vibrations of a properly formed overcoil hairspring. Also, the lecture included the vibrations of a pendulum, hairspring, and tuning fork. In addition, the point at which the frictional errors in a time keeping element will result in either a fast or slow rate was fully explained. The students were then required to form a gradual rise overcoil, and this time the best quality of work was required. The students performed very well in this respect and turned out work that was comparable to the work of a student who is in his last months of training in a reputable school. At this point, a new disassembly and assembly procedure booklet was distributed to all the students, and it was explained to them that they should read this book and especially become

acquainted with the names of the parts illustrated in the disassembly and assembly procedure. (see Appendix A)

February 15

All screwdrivers and tweezers were checked by the students to see if any needed to be sharpened, and then the instructors checked all these tools. The students were told to follow the step-by-step procedure illustrated in the text book on the disassembly and assembly of the particular watch that they had been given to work on. With the use of this book, the students proceeded to disassemble the movement. The movement was then checked, and the students were required to reassemble the complete movement. Nearly every student in the class disassembled and assembled the watch two or three times very successfully without damage or breakage of any part. In addition, each movement ran after it was completed. It is surprising to note that out of 29 students who performed this task, only one screw was lost. We were especially interested to find out if, for example, the procedure for letting down the power on the train would be followed correctly as this requires a certain amount of coordination. We were very pleased that the explanation in the text book and the illustrations made individual instruction almost unnecessary at this point.

February 16

Students spent the entire day on disassembling and assembling the movement. At this point they were working from memory and not relying on the disassembly and assembly procedure outlined in the booklet prepared for that purpose. We were especially concerned as to whether they were using their tweezers and screwdrivers properly in handling the parts. Each time the students had the movement disassembled completely, the instructors would check it and have the student reassemble it again. Checks were made after the movement was assembled to see that all the parts were in their proper place, that the balance unit was placed so that the roller jewel was in the slot of the fork, that the screws were screwed down tightly, that the winding and setting mechanism was operating properly, and special attention was given to the clearance of the second hand, hour hand, and minute hand. The movement was then wound to start it running.

February 17

The students were lectured on the proper use of the ultrasonic cleaning machine. Full information was given to the students pertaining to the way that the parts of the watch should be arranged in the cleaning basket. Each student was then required to disassemble his movement and place the parts in the basket, and the instructors checked all the parts before the basket was placed in the cleaning machine. A demonstration was then given showing how the machine was to be used along with information pertinent to the ultrasonic features, such as the slow agitation of the basket to give best results, the length of time that the basket should be in the solution, the raising of the basket above

the level of the solution to spin off the excess solution, and the fact that special care must be taken not to spin the basket too long above the level of the cleaning solution so as to avoid a drying effect of the solution on the parts. The rinsing operation was fully covered concerning such matters as the proper method of moving the basket from one jar to another, the submerging of the basket in the rinsing solution, and again, the care that must be taken not to agitate the basket too fast in any of the solutions. A special point was made to the effect that the basket should never be agitated when it is out of the solution, but spun only in one direction. The drying operation was expressed in such terms as "the basket should be hot enough that it is uncomfortably hot when held in the hand."

February 20

The students were lectured on the proper method of oiling a watch. At this point, the Bergeon fountain oilers were filled with oil and the students were instructed on the proper use of this particular type of oiler. Special attention was given to the oiling of balance jewels in reference to the capillary attraction that will hold the oil between the cap jewel and the hole jewel, due to the curved surface of the hole jewel and the flat surface of the cap. Students were required to use the microscope at this point to see that the globule of oil was formed properly in the balance jewels when they were oiled. Emphasis was placed on acquiring the proper sized oil ring in the balance jewels. The upper escape jewel in this particular watch was fitted with a cap jewel, so these jewels were oiled in exactly the same way as the balance jewels. The students were then required to oil the train jewels in the watch, placing enough oil on each jewel to form a ring of oil around the pivot of each wheel. Students had some difficulty in oiling certain train jewels without smearing the oil over the outer surface of the jewel. Also, some difficulty was encountered in the student over-oiling or flooding the balance jewels.

February 21

Students were required to re-clean their watches, so that they could re-oil them, and this time they were expected to oil the balance jewels and train jewels without smearing the jewels or flooding. The students spent the entire day bringing their work up to the quality that could be passed by the instructors.

February 22

A lecture was given to the students on the proper use of the timing machine, showing the use of the indicator dial to determine whether the watch is running fast or slow. Also covered were such factors as how an out-of-beat reading will appear on the timing machine paper and the difference between an 18,000 standard beat watch and fast beat watches. Reference was made to the regulator pins and how they affect the rating of a watch. The students were told how to set the regulator pins properly and how the hairspring should be adjusted in reference to the

regulator pins. Special attention was given to the level of the hairspring in the watch, and the students were required to raise or lower the stud to place the hairspring in a perfectly flat position in relation to the balance wheel. Each student was required to place his watch on the timing machine and to take the rate of the watch in dial up, dial down, and pendant down positions.

February 23

Students spent the day on completing the watch, cleaning, oiling, and adjusting the hairspring to proper level and position in the curb pins to bring the workmanship up to the quality expected by the instructors.

February 24

Students were lectured on the proper method of removing a hairspring from the balance wheel. At this point, each student was required to remove the balance assembly from the watch, to remove the hairspring from the balance wheel, and to check the balance wheel for trueness. Actually, all the balance wheels were almost perfectly true, so the instructors bent them out of true and had the students retrue them. The students were then required to poise the balance wheels. We found that although the balance wheels were from new watches, they were out of poise, and the students were required to statically poise the balance wheels.

February 27

A talk was given to the students pertaining to the method used to find the proper position to place the hairspring on the balance wheel for beat. The balance was placed in the watch without the hairspring, and the balance was moved to a position centering the pallet fork between the banking pins. An imaginary line was then drawn from the center of the balance jewel through the stud to the balance wheel, to locate the proper position the hairspring stud should occupy in relation to the balance wheel. The students were required to place the hairspring on the balance wheel with the use of the staking set and to replace the balance unit in the watch. Each watch was then checked by the instructors.

February 28

Students were given a lecture on the proper procedure to follow to staff a balance wheel. Information was given on the proper type of punches that should be used in the staffing operation, the type of hammer that should be used, the proper method of centering the staking set, the proper fit of the punches on the staff, et cetera. In addition, the students were given certain objectives pertaining to staffing, such as riveting no more than necessary to bring the balance to a point of being secure on the balance staff, proper method of checking the balance staff to see that it is riveted securely in the balance wheel, and

techniques used to keep the balance wheel from being thrown out of true while staffing. At this point, the students were instructed on the proper arrangement of the punches in the staking set so that the punches that are most frequently used will be in a position that they can be easily removed from the staking set without the need of the special punch gripping device. The information pertaining to the special arrangement of the punches in the staking set is included. (see Appendix F) The students were then issued a balance wheel and a staff to fit and were required to select punches to fit that particular staff. Since the staffs that were issued to the students were all the same size, we had the students in the class call out the numbers on the punches that they had selected. Whenever a student had selected a wrong punch, the instructors examined the punches selected and showed the student where he had been mistaken. The instructors then proceeded to demonstrate the actual staffing operation and each student was required to staff a balance wheel. After the students completed the staffing operation, the instructors checked the balance wheels and had the students proceed to true and poise the balance. The roller table was not placed on the balance staff until after it was trued but before poising the balance.

March 1

The students were given a lecture on the proper fit of the roller table to the balance staff and the problems that can arise in replacing the roller table. Also, an explanation was given of the location of the roller table with reference to the roller jewel. The students were then issued two additional balance wheels and staffs to fit. This time particular attention was drawn to the fit of the balance wheel on the rivet shoulder and the necessary amount of rivet that must extend above the level of the bars. The students were then required to staff these balance wheels and then proceed to true and poise them.

March 2

Students were instructed on the proper method of putting a watch in perfect beat. They were instructed to observe the travel of the escape tooth up the impulse face of each pallet stone with a minimum of power on the train of the watch to determine the direction to move the collet on the hairspring in order to equalize the travel of the escape tooth on each pallet stone. The full day was spent throwing the watches out of beat by the instructors and having the students put the watch back in perfect beat and then making a record on the timing machine to indicate perfect beat.

March 3

Students were given a lecture on the proper use of the watchmaker's lathe. Each student was required to coat his lathe with a special lubricant to prevent rust, and the belting was then cut to fit each lathe. The students were taught how to connect the belt by heating the ends to fuse them together. An explanation was made concerning how the gravers should be sharpened for use on the watchmaker's lathe. The students

proceeded to grind all the gravers as per the instructions, using the special graver sharpener provided for this purpose. A piece of brass rod, size 32, was issued to each student. The students were cautioned on the mistake of fitting a piece of material improperly to a chuck, explaining the damage that could occur. Also, information was given to the students in reference to the chuck being clean and the portion of the lathe in which the chuck is seated being clean. The students were then instructed to place the 32 brass in a 32 chuck in the lathe and to tighten it by turning the spindle, allowing only about 1/4 inch of the brass to extend out of the chuck. Every student was then required to adjust the T-rest on the lathe to proper height for cutting and to place the graver on the T-rest in the proper position. While the students were holding the graver on the T-rest, the instructors checked to see that each student had his T-rest set to proper height and that he was holding the graver properly. A demonstration was then made to show the students how to cut square shoulders on brass. The entire day was spent in having the students become familiar with the use of the graver in cutting square shoulders.

March 6

The students were given a lecture on the proper use of a micrometer and how to read a Boley millimeter gauge. The students were informed that they were to be given a written test on March 10 to cover the first four weeks of their course and that each morning we would spend some time in reviewing the various subjects covered during that period. The students were kept on turning brass during the entire day, cutting shoulders to various dimensions, in order to get them acquainted with using the Boley gauge in particular.

March 7

About 1/2 hour was spent in reviewing subjects taught from February 1 to 28. Each student was issued a piece of steel rod about six inches long. This steel was in its soft state, and each student was required to turn square shoulders on the steel. The entire day was spent in getting the student to do a good job in reference to finish and to produce sharp corners in shoulders.

March 8

About 1/2 hour was spent reviewing. The students were then given a demonstration on how to turn undercuts and bevels. Next, the students were instructed on the proper shaping of the cutting edge of a graver to be used for turning conical pivots. The students were then informed about the proper method of applying this graver to the steel to obtain the best results. Following a demonstration, the students spent the remainder of the day turning undercuts, bevels, and conical balance pivots.

March 9

About 1/2 hour was spent reviewing. Then each student was issued a drawing of a balance staff with dimensions for each portion of the staff. Students were required to cut a half staff. The students worked the entire day on this, and many of them succeeded in producing a half staff on soft steel that was exceptionally good.

March 10

A written test was given to the students which took about 1 1/2 hours to complete. Samples of test questions are included in Appendix G. The students were required to cut three pieces of steel rod an inch and a quarter in length, to be used for hardening and tempering. The students were then given a talk on the proper methods of hardening steel and the various colors that the steel will pass through in the tempering process. At this point a demonstration was given to groups of four or five students at a time, showing the proper procedure to follow in hardening a piece of steel. When the demonstrations were completed, the students were all required to harden the three pieces of steel that they had cut off previously. Having completed hardening the pieces of steel rod they then proceeded to remove the scale from the rod by placing the steel rod in the lathe and using emery to bring the steel back to a bright finish. A demonstration was then given to the students of the proper procedure to follow in tempering the pieces of steel rod to a spring steel hardness, which is blue temper. The students were then required to temper all their steel, and the remainder of the day was spent with the students cutting shoulders and becoming acquainted with lathe turning of tempered steel.

March 13

The students spent the entire day attempting to make half staffs out of tempered steel. They had quite a lot of difficulty in keeping their gravers sharpened, as the tempered steel was very difficult to cut in comparison to the soft steel the students were accustomed to working with up until this point. This full day was spent in getting the students properly oriented on the various techniques used in cutting tempered steel so as not to dull the graver.

March 14

The students were instructed on the proper procedure to make a parting tool out of a six-inch piece of 48 mm diameter drill rod. They first were required to file a 3 mm square and then to file the proper shape of the parting tool on the end of the square to specified dimensions. When this was completed satisfactorily, the students were required to harden and temper the parting tool to a very pale straw. The students were then informed that they must make a finished half staff from tempered steel to be turned in to the instructors for grading by the end of the week.

March 15 and 16

The students spent nearly all of these two full days making the half staff which was to be turned in for grading. In addition, they used the parting tool to form the roller side of the staff just prior to cutting it off. The half staffs that were turned in for grading were fairly high quality. Most students during this period made several half staffs, but of course, turned in to the instructors the one which was of the highest quality.

March 17.

A lecture was given to the students pertaining to the procedure to follow in making bushings to serve as bearings. Drills were issued to the students and they were instructed on the proper procedure for drilling very small holes. The students spent the entire day making bushings, and they were required to turn in a bushing at the end of the day to be graded. A great deal of emphasis was placed on the high finish of the bushing. To accomplish this, the gravers had to be highly polished and brought into contact with the brass while it was turning at a high rate of speed. The graver was shaped appropriately to make a curved cutting surface in order to shape the cup in the bushing.

March 20 to March 24

The students spent this entire week learning the functions and adjustment of the detached lever escapement. A Barkus escapement model was issued to each two students, so that they could make all the adjustments on the model in accordance with the instructional material that was supplied to each student. The procedure that was followed is covered in the booklet entitled "Section I, The Detached Lever Escapement."

By March 24, the students were capable of resetting the lever escapement and making accurate adjustments in every respect on the escapement model. Complete information pertaining to the lever escapement, in reference to the function and adjustment of this mechanism, was included. The students were informed that at a later date they would be returned to the escapement to work on this mechanism within the watch itself, rather than on the escapement model. They were also informed that at still a later date, a checking system for setting and adjusting the escapement would be taught which would incorporate the most advanced techniques developed to examine the escapement functioning characteristics.

April 3, 4, and 5

The students in the class were all issued an ammeter and instructed, step-by-step, on how to disassemble this meter and assemble it again. The hairsprings in the meter had to be unsoldered at their point of attachment in order to disassemble the meter completely. The students were then instructed on the proper procedure to follow in reassembling the meter, and they were given full information in reference to the

function of the meter, the balancing of the armature, and the proper procedure to follow for zeroing and calibrating. When the students had completed the task of disassembling, assembling and re-adjusting the meters, they were given milliammeters, micro-ammeters, and voltmeters to disassemble, assemble and adjust in the same way that they had done with the ammeter.

In the period that the students spent working with various types of meters, each student had at least three different meters to disassemble and assemble. A few students were able, in that period of time, to work on more meters than the three required. All students in the class performed very well and were pleased to learn how easily the skills they had developed in watch technology were transferred to related areas of instrumentation.

On the days the students were engaged in working with meters, a 30-minute lecture was given each morning on the subject of the lever escapement. The lecture was more or less a review of everything that they had been taught the previous week. At this point, the students were informed that on April 7 they were to be given a test on the function and adjustment of the detached lever escapement.

April 6

The students were issued a watch movement to disassemble, clean and overhaul. It was required that the students make ten checks on the watch as they assemble it in order that they cover the areas in which they have developed acceptable skills. It was explained to the students that the 10-point checking procedure did not cover all the things that should be checked to ensure the proper operation of the timepiece but only those areas in which the student has had previous training. An explanation was then given to the students on how each of these checks should be made. The student was also informed that after he has completed each check within the watch he should then bring it to the instructor for examination. Any defects could then be pointed out by the instructor. In this way, the student was brought to realize the importance of making these checks as accurately as possible so that the instructor would approve his work.

April 7

The students were given a written examination on the subject of machine work and the function and adjustment of the lever escapement. These subjects were covered during the previous month of training. Samples of test questions are included in Appendix G.

Having completed the examination, the students were then required to complete the cleaning of a watch and to follow through with the step by step checking procedure which is required for every watch that is worked on. Whenever a student over-oiled, smeared, or flooded the balance jewel, it was required that he completely reclean the watch. Many

of the students had to disassemble and clean the watch two or three times before the quality of the work came up to the standards required by the instructors.

April 10 and 11

The students were given a lecture on the proper procedure to follow in removing and replacing roller jewels. Information was given on the proper handling of the roller jewels, proper cleaning procedure, method of applying the shellac to the roller jewel, the tools that are used in performing this task, and how the heat should be applied to melt the shellac. Students were especially cautioned on how to heat the shellac without burning it. It was also fully explained how the roller jewel should be checked in three different positions to determine if it is set properly and the importance of the roller jewel being the right size. Factors concerning the procedures to follow to determine the proper size of the roller jewel were not covered at this point; however, the students were informed that the size of the slot in the fork is the determining factor in regard to the size of the roller jewel. The instructors then proceeded to give a demonstration of replacing a roller jewel in a roller table. Since only about five students could view this operation at one time, the demonstration was repeated until all the students had viewed this operation.

The students were all issued balance wheels in which they were to remove the roller jewels and replace them, in accordance with the procedure previously outlined. At the end of the second day, the students were still having some difficulty occasionally with inserting the roller jewel in the roller table. However, overall, the students did very well and had removed and replaced roller jewels many times during this two-day period.

April 12

The students were given a lecture and demonstration of straightening train wheels within the watch and then with the use of truing calipers. During this day, the students were required to straighten train wheels that the instructor had bent out-of-flat and with few exceptions the students had little difficulty in performing this task.

April 13 and 14

The students spent these two days in overhauling watches which included disassembly, cleaning, assembly, checking, and rating. During these two days, the instructors worked very closely with the students to be sure that they were using their tools properly and that they were doing each job in accordance with the proper techniques that were previously taught. At this point, the students were doing exceptionally fine work. They could properly disassemble, clean, assemble and oil a watch, making all the checks to insure the proper functioning of each and every part. The movements, in fact, looked like they had just been received from the factory, without any fingerprints or any other sloppy,

telltale signs which would indicate in any way poor workmanship. The oiling, which we were especially concerned with at the time, was properly accomplished, and the beat and rating were also satisfactorily accomplished.

During this period, April 10 to April 14, a lecture was given daily reviewing every topic that was covered since the program was started on February 1. However, only about 15 to 20 minutes a day were devoted to this review.

April 17

The students spent the first part of the day in reviewing the various checks that should be made in the cleaning and overhauling of a watch to insure that it is functioning properly. Some of the students did not complete the last watch on which they were working and were required to put it aside to be completed later. In general, the instructors made sure that each student had such work set aside at all times. By doing this, at no time could a student claim that he did not have something to do while, for example, waiting on some piece of equipment, et cetera. The students were then instructed on how to make a collet tool for hairsprings. This tool is made of drill rod steel and is driven into the center of a wood handle so that it will turn true if the handle is rolled on the bench. The tool was hardened and then brought to a blue temper so that it would stand up under the strain of pinning and unpinning hairsprings at the collet.

April 18

The students were given a demonstration on the various techniques of straightening a hairspring in the round. Special attention was given to the extreme conditions that exist whenever a hairspring is bent so far out-of-round that one coil laps over the top of another. They were shown how to cup the hairspring to separate the various coils in order to determine where the bend must be made to straighten the hairspring. Emphasis was placed on the objective of determining whether the wide space or the narrow space should be corrected first in straightening a hairspring in-the-round. The students were first brought to realize that whenever there is a wide space between the coils there must also be a narrow space which is usually located directly opposite the wide space. Demonstrations were made to show that whenever the wide or narrow space between the coils is corrected, the other spacing automatically comes into place. It was very important to get the students to understand that whenever a wide space and a narrow space exist between the coils of the hairspring, the correction, which must be made first, is on the error that exists closest to the collet. If the wide space is closest to the collet it should be corrected first, and vice versa if the narrow space is closest to the collet. The students spent the entire day working on hairsprings to bring them into round to a degree that was acceptable to the instructors.

April 19

The students were given a demonstration on how to remove a tangle from a hairspring. They spent the balance of the day in removing tangles and straightening hairsprings in-the-round, working first on the outside coils, and then on the inner coils, closer and closer to the collet.

April 20

The students were instructed on the various techniques used to straighten a hairspring in-the-flat. Three basic techniques were shown. The first technique incorporated the use of two tweezers. The second technique necessitated the making of a spatula which was used along with a pair of tweezers to make bends in the hairspring in order to correct out-of-flat conditions. The third technique was devised as a speed method of straightening hairsprings and necessitated the use of only one pair of tweezers. The third method brought about a great deal of interest from the students. The remainder of the day was spent in straightening hairsprings, using the first and second methods indicated above.

April 21

The students were again shown how to straighten a hairspring in-the-flat using the speed method, which requires a little more skill but the straightening is done much faster. They spent the entire day straightening hairsprings using this method and exceptionally fine results were obtained.

April 24 to April 28

The students spent this entire week working on the escapement in reference to adjusting it in every respect within the watch itself. The same information covered in the function and adjustment of the detached lever escapement book was reviewed and the techniques used to make these checks within the watch itself were demonstrated and explained during this period of training. The students were all issued an A. Schild 1525 movement to set and make adjustment to the escapement. Since the watches that were issued to the students were all new, the students had a good chance to make all the checks on an escapement that was properly set and in factory-like condition. It was then explained to the students how to properly use a pallet heater, and how the pallet stones can be moved in and out of their slots in order to make necessary adjustments. The students were then required to use the pallet heater and to move the stones as instructed. This done, the students were required to move the stones all the way back into their slots. During this period of training, we did not have the students remove the pallet stones from the fork. The full week was spent in studying the techniques used to adjust the escapement within the watch. We are simply making the designation "in the watch" here in order to clarify the difference between the procedure that was followed previously with the use of the escapement model.

By April 28, all the students in the class were capable of setting a detached lever escapement correctly and making all the checks necessary to insure that every adjustment was satisfactorily made.

May 1

The proper procedure for removing and replacing a stud on a hairspring was explained to the students and then a demonstration was given to them. They were then required to remove and replace a hairspring stud several times. At this point, a lecture was given to the students on the proper procedure to follow in unpinning a hairspring at the collet, which included how to remove the lip of the hairspring from the hole in the collet without damaging it. The replacing procedure was also fully outlined in reference to how the hairspring must be centered around the collet, how to identify the upper and lower part of the collet itself, and the proper procedure for pinning the hairspring to secure it to the collet. The students spent the entire day in pinning and unpinning hairsprings and performed this task very well.

May 2

The students were required to place the hairspring on which they had worked the day before on a balance cock and a lecture was given to explain how the hairspring should be leveled and centered on the balance cock. Special attention was given to the quadrant and how it should be formed so that it would be properly centered between the curb pins as the regulator is moved from fast to slow position. The entire day was spent in having the students level and center hairsprings on the balance cock.

May 3

Since the students were having difficulty in forming the quadrant of the hairspring between the curb pins, the subject was completely reviewed by the instructors. It took the entire day in working with the quadrants to bring the students up to the point of reasonable acceptance. It is recognized that this is a rather difficult task to perform, and it was expected that the students would have difficulty in this area of work. However, by the end of the day, the students, although slow, were capable of bringing the quadrant to a position so that when the regulator was moved from fast to slow, the hairspring remained centered between the curb pins.

May 4

The students spent about two hours in completing the leveling of the hairspring, forming of the quadrant, and centering of the collet of the hairspring over the balance hole jewel. They performed very well and with very few exceptions acquired the necessary skill to make these manipulations without difficulty.

The students were given a lecture on the proper procedure to follow

in straightening a hairspring within the watch. They were then required to prepare a watch for practice. This was done by having the students remove all the parts from the watch, with the exception of the balance wheel, hairspring, and balance bridge. This helped the students in their first experience in working on a hairspring within the watch as they could see all around the balance which made it easier for them to place their tweezers on the hairspring at the desired point without having other parts of the watch interfere.

May 5

A demonstration was given to the students on the proper manipulation of the tweezers to work underneath the balance bridge to make desirable bends in the hairspring in order to level and center it. The entire day was spent in having the students level and center the hairspring in the watch. In the cases where the hairspring could not be straightened within the watch, due to it being bent out too far or the position of the bend was such that the proper manipulations could not be made, the students were required to lift the bridge up out of place in order to make the bend.

Starting on May 1, a review was made of all phases that had been covered in this training program since the beginning. The students were informed of a test of 50 questions which would be given on May 12 as a first-semester examination.

May 8

The students were required to make a special tool to be used in putting a watch in beat. The making of this tool gave the students some practice in filing. Each end of the tool was made to the same dimensions, thus, there would be two tools made from one piece of steel. The tool had to be hardened, tempered, and ground down to the proper dimensions to be used as a collet mover. Before allowing the students to begin, a lecture on the subject of filing was given to the students. They were all required to closely examine the files to see that the cutting edges of the file are like small, sharp teeth which all slope away from the handle. It was explained to the students that when using a file the pressure should always be applied as the file is forced away from you. As the file is drawn toward you, the file should either be lifted clear of the object or allowed to ride across the surface without pressure. It was further explained that a file should never be rubbed back and forth on the work as one does in using emery paper or a stone. Such data as the use of carpenter's chalk on files, the fact that files should never be thrown together in a drawer as this may damage the fine, sharp teeth on the file, et cetera, were fully covered. The students were informed of the proper procedure of filing a straight or tapered pin, draw filing, filing of flat washers, and filing of convex washers.

May 9

The students were required to alter the square on a stem, reducing the square by .10 mm. Stems were distributed to each student for this purpose and they were required to file a square on the threaded portion of the stem, first for practice and then to proceed by filing the square itself and reducing it in size to the specified measurements. A demonstration was given to the students on how to file a square properly and the proper use of the index in the lathe for this particular operation.

At this stage, they were not allowed to use any support for the file such as a special filing fixture or filing rolls in doing this work. The purpose here was to develop the skills necessary to handle a file to produce a flat, straight surface.

May 10

The students were issued hairsprings and were required to remove the hairspring from the collet. They were then shown how to break off the inner lip with the use of two tweezers on a hardwood block. They were then required to repin the hairspring to the collet and level and center the hairspring by adjusting the inner terminal.

We believe it is most important that the students be returned to hairspring work as often as possible because it requires a highly developed skill to perform well in this area of watch technology.

May 11

The students were issued pallet forks which were to be used to remove and replace pallet arbors. Full information was given to the students in reference to the procedure to follow in order to accomplish this task without difficulty. It was emphasized that the pallet arbor must stick in the hole of the pallet fork before attempting to press the pallet arbor into position. It was explained to the students that the friction jewel tool is the most desirable tool to use for replacing pallet arbors. However, for this particular operation we chose to have the students use their staking sets so that they could do this job without the use of a friction jewel tool if necessary. The students were required to remove and replace pallet arbors for the remainder of the day.

May 12

The students were issued two staffs that were slightly oversized for the balance wheels that they had been issued for staffing some weeks before. The students were required to alter the staffs in order to make the roller tables and balance wheels fit. This done, they were required to rivet the staffs into the balance wheels, true the wheels, replace roller tables, and then proceed to poising. The complete day was spent in this phase of work.

May 15

The students were issued additional staffs in which only the rivet shoulders had to be altered in order to fit the balance wheels. The students were required to alter the staffs to fit and to proceed to rivet, replace rollers and true and poise the balance wheels.

May 16

The students were all given watch movements which they were to disassemble, clean and assemble to restore to good operating condition. The students were required to record the time at which they started on this particular watch and to record their finishing time so that the instructors could determine whether or not the students were working fast enough. Many of the students spent over 3 1/2 hours to complete the overhaul of their watch movement. The time which they spent in waiting for a cleaning machine, et cetera, was deducted from the total time, so that the time recorded was the actual time that the students spent on the watch itself. Any student who required longer than two hours to clean a watch was informed by the instructors that on the next watch he cleans he should pay particular attention to any part of the work in which he was having difficulty and that would delay the completion of the job. The instructors then questioned the student further as to why it took so long for him to complete the cleaning job on the previous watch. The student was then given a new movement on which to work.

May 17

All the students spent this day disassembling, assembling, cleaning and overhauling watches, trying to reduce their time to 1 1/2 hours, which is the recommended time for students to spend in the cleaning phase of a watch during this period of training.

May 18

The students were returned to hairspring work and a complete review of all that had been taught previously was scheduled for these two days, May 18 and May 19. The students were required to straighten hairsprings in-the-round, straighten hairsprings in-the-flat, remove tangles from hairsprings, level and center the hairspring on the bridge, and make manipulations on the hairspring within the watch itself.

May 19

The students were required to work on the quadrant of the hairspring and to adjust the hairspring so that the quadrant would remain centered between the curb pins as the regulator is moved all the way from slow to fast position. Having completed work on the quadrant, they then were required to work on the centering and leveling of the hairspring on the bridge. The entire day was spent in having the students complete the review of hairspring work.

May 22

The students were given a lecture on friction jewelery. They were informed that the balance wheel, fork, and escape wheel should have .01 mm clearance of their pivots in the jewel holes, that the third and fourth wheel should have .02 mm clearance, and the center wheel should have .03 mm clearance. The different types of jewels that are used in watches were also explained to the students. A drawing was made on the blackboard of each type of jewel used in watches: the balance jewel, plate jewel, all hole jewels, etc.

At this point, the students were informed of the relationship of the balance jewel to the cap jewel, and the space that should exist between these two jewels. Information was then given on the measurements that must be taken in order to determine the proper size jewel to use in each case and how the reamer in a friction jewelery outfit is used to ream out a hole for a jewel when necessary. It was further explained to the students that the diameter of the jewels are available in tenths of a mm, such as .9mm, 1 mm, 1.1 mm, 1.2 mm, et cetera, while the reamer sizes run in odd numbers such as 99, 109, 119, 129, et cetera. It was brought out that the jewel diameter must be .01 mm larger than the reamer that is used to ream the hole for the jewel. The proper method of ordering friction jewels from the material house was fully covered and the method that was used prior to the development of the friction jewel for watches was explained. A demonstration was then given to the students on how to remove and replace friction jewels properly. Six students at a time were given this demonstration. The students were then required to remove the jewels from the watch on which they were working and to reset the jewels in their proper position. As soon as one group had completed this, the friction jewelery tool was passed on to the next group so that they could proceed in the same way, which consisted of removing a balance jewel, cap jewel, and several train jewels and replacing them in the proper position with the use of the friction jewelery tool.

May 23

The students were given a talk by Mr. James W. Cummings of the Coordinated Science Laboratory here at the University on micro photo-milling. The students were then required to visit the laboratory so that a demonstration could be given of all the phases of micro photo-milling that could be viewed at first-hand. Six students per day were required to visit the photo laboratory which required about two hours of their time.

May 24 to May 26

The students were kept on overhauling watches and every effort was made to help them speed up so that they could complete an overhaul within 1 1/2 hours. They were required to record the starting time and the finishing time of each watch on which they worked. A talk was given to the students daily, usually in the form of a question and

answer period, in order to help review all material that had been covered up to date in this course.

June 5 to June 9

The students were issued a watch movement to disassemble, clean, and overhaul. A checking list was also issued to each student which consisted of 16 checks that should be made on every timepiece to insure that it will function properly after it is assembled. It was required that the student make each of these checks with the instructor. A list of the 16 checks is included (see Appendix C) along with an explanation of how each check should be made in order to insure the proper functioning of each and every part of the watch. As a control for the instructor, the students were required to fill out a worksheet on every watch so that the instructor could initial the worksheet every time the student made a check. This procedure prevented students from skipping checks that should be made and also made it easier for the instructor to see who was not progressing fast enough. During this week, the students were taught how to polish balance pivots with the use of the balloon chuck. They were then required to polish the pivots on some practice balance wheels. The students were further informed that as a matter of practice they would be required to polish the balance pivots on every watch on which they will be required to work. During this period, the students were coached on the proper procedure for measuring the slot in the pallet fork to determine the proper size of the roller jewel to be used in the watch. Every student was required to measure the fork slots in three different pallet forks and to report to the instructor the size roller jewel that would work properly for each pallet fork. Since the roller jewel gauge comes in only every two sizes, some of the students had a little difficulty in determining the exact size of the slot in the pallet fork. This was soon cleared up by giving a demonstration. The students were also informed as to the problems that would result from having excessive clearance of the roller jewel in the slot of the fork and the trouble that would result from having a roller jewel fit too neatly in the slot. They had all been previously informed that .01 mm clearance of the roller jewel in the slot of the fork was the correct amount.

June 12 to June 16

The first hour every morning was spent in asking the students general questions about the field of horology. The students were informed that they would be given a general review examination on June 20 and that they should review all the subjects that they had been taught. During this week of training, the students were required to completely overhaul watches using the 16-point checking procedure. The instructors altered the watches so that the students would engage in just about every type of repair that one normally encounters in servicing watches, such as straightening hairsprings, resetting escapements, straightening train wheels, polishing pivots, truing balance wheels, staffing, poisoning, and so on. The students were asked to submit any questions that they might have about any subject that was previously covered in preparation for the forthcoming examination to be answered each morning as

a class review. In this way, all the students would benefit from any particular problem that a student might be having in his daily work.

June 19

The first hour in the morning was spent in reviewing and answering students' questions in preparation for the test which was to be given to them. They were told that eight students would be selected to take this examination each day and that a list would be posted of the eight students that were selected to take the examination the following morning, June 20. Since all the students were not going to take the test at one time, we knew that there would be some transfer of testing information. We were not in any way concerned about this because the examination that was prepared covered nearly the entire course of training up to this point. Also, since the students did not know which persons were going to be selected each day, there was a great deal more discussion, interest, and activity among the students in preparing for the examination than is usually evident in most examinations that have been given in the past. Unknown to the students, it was arranged that the students selected to take the examination on the first day were the "A" students and the second group selected were the "B" students and so on. In this way the poorer students had a longer period in which to study and were motivated by the comments that were made by the students that had already taken the examination. We must say that the additional studying, preparation, and discussions that were evident prior to the examination helped tremendously. Overall, out of the eighty questions that were asked on the examination, (samples are included in Appendix C) we had only two students make below 85% on this examination. The results obtained by giving the examination in this way indicates that it is worthwhile and should be used occasionally. In preparation for the examination, it was suggested to the students that they use two technical books to do their studying. These technical books were well known in the industry and covered the field of watchmaking generally. The students, during this period of training, improved considerably in their technical knowledge of the field although all the subjects in which they were being tested were covered in the past. During this week, while the eight students each day were involved in taking the examination, the other students were required to proceed with completing the overhaul of one watch after another. We did not cover any new material during this period as the students that were involved in taking the examination could not be included in the coverage of any additional or new information. It was the primary objective of the instructors during this week to help the students become more efficient in the cleaning and overhauling of a timepiece. From June 20 until June 23 there were no daily review sessions in the morning as was usually done. Although the students were allowed to take their examination at their benches, it was announced that all students should be very quiet and that we wanted no comment at all to take place among the students during this time as a courtesy to those taking their examination. The students complied very well with this request and the class was extremely quiet throughout the periods of testing.

June 26 to June 30

Due to the students forgetting certain aspects of training which were previously covered, it was decided that each morning an hour should be spent in an oral review of all the subjects that had been covered previously and to answer any questions that the students may have pertaining to horology. Although we have used about 45 minutes each morning for lecturing and reviewing in the past, this was not done consistently every day and it was at this point that a decision was made to use the first hour in the morning to take up and discuss such matters as the problems that a watchmaker or micro-precision technician may encounter in his daily work. On June 26 a setup was made on a lathe with cross slide and milling attachment to cut a gear. We had all the students view this operation and explained to them all the details involved in setting up the equipment for gear cutting and in addition had each of the students cut a few teeth on a wheel.

June 27

The students replaced guard pins and curb pins after a lecture and demonstration was given on the proper procedure to follow in order to accomplish this task with the least difficulty. The students, during this period from June 27 to June 30, continued with complete work which constituted the overhaul of watch movements. We also announced to the students that we were making available additional time for the lab. to be open for those students who would like to come back in their spare time and spend some extra time at the bench. Some of the students had already been coming in on Saturday to put in extra hours in the lab. We especially suggested to the students that they spend any extra time that they may have to work on hairsprings, filing, and micro-precision machine turning. We are, at this stage of training, especially concentrating on adjusting watches to position and isochronism. Up to this point, we have only covered in lectures the subject of dynamically poising the balance wheel. At this stage the students were ready to master the practical aspects of dynamically poising balance wheels with the use of the timing machine. The students performed very well on this subject and were capable of locating the heavy spot on the balance wheel and bringing the balance to dynamic poise very effectively. We have discussed with the students counterpoising and demonstrated how counterpoising can be done but that we do not recommend such practices. The students have been made aware of the pinning point error and that there is normally a slow position in every watch - that the pinning point should be in such a location that the slow position will be the pendant-up position in a wristwatch and the pendant-down position in a pocket watch. The students have been lectured on the effect of frictional errors in a watch and its relation to time. It was also pointed out that the vertical positions will have less motion than the dial positions due to the increased pivot friction.

In the weeks to come, greater emphasis will be placed on the other aspects of adjusting watches. At present, when a student completes a watch and places the watch in perfect beat, the movement is then examined by the instructor. The student then proceeds to take the dial-up and dial-down rates on the timing machine and if these rates do not

agree with one another he does not take the rate of the watch in the pendant positions until the watch is first checked by the instructor. If, on the other hand, the dial rates do agree, then the student is permitted to take the pendant-up and pendant-down rates on the timing machine, and then the pendant-right and the pendant-left rates. At this point, the condition of the watch is observed by the instructor in reference to the rates taken and the student is informed of how the expert watchmaker would proceed to adjust a watch in which the rates were not as good as they should be. It was expected that the student would spend about three weeks concentrating on the complete overhaul of watches and especially the rating problems that he will encounter. Special emphasis was placed on the proper procedures to follow in detecting any positional errors and the methods used to correct them.

July 3 to July 12

We continued with the process of acquainting the students with all of the technical data involved in rating watches and had the students not only rate the particular watch upon which they were working but actually had them create various errors in the watch so that they could observe the effects on the timing machine. A review of the laws governing frictional problems in a watch which will produce rating problems was covered. Great emphasis was placed on the application of the rule that any force working with the forces of the hairspring produces a fast rate, and that any force working against the forces of the hairspring produces a slow rate. It was further explained to the students that the total effect of the escapement upon the time keeping element of the watch is to produce a slow rate. The students were informed that the unlocking action of the escapement produces a slow rate, that the first half of the impulse produces a fast rate, the second half of the impulse produces a slow rate, and any impulse due to the draw of the fork to the banking pin also produces a slow rate. In reference to pivot friction, the students were informed that any friction that resists the turning of the balance wheel as the balance moves away from its rest position will produce a fast rate and any friction occurring to the balance wheel as it moves toward its rest position will produce a slow rate. Thus, if the pivot friction is constant there will be no change in rate due to friction. They were further informed that such factors as the isochronal error may come into play at this point when the balance motion is decreased due to pivot friction. It was made very clear to the students that friction can produce either a fast or a slow rate depending upon when and how the friction is applied. The students were required to make a large number of experiments in this respect and to analyze every condition and situation that the instructor could present in order to give the student a full understanding of what is involved. A review of the effect of curb pins upon the isochronal rate of the watch was presented to the students. We were especially concerned with the students understanding that the space between the curb pins should be a little as possible and that if the space is increased the long arcs will be performed in a shorter period of time than the short arcs. It was further pointed out that the vertical positions of the watch will usually be slower than the dial positions and for this reason the curb pins should

be kept as close together as possible with as little breathing of the hairspring between the curb pins as can be set without the curb pins catching on the hairspring as the regulator is moved. A demonstration was given on the effects of curb pins upon the rate of the watch. The curb pins were first set very close together then opened widely and the rates were taken. The next step was to have the hairspring bounce off of one curb pin to show how this can cause the short arcs to be performed in less time than the long arcs.

July 13 and 14

We returned the students to hairspring work. Each student had the instructor bend the hairspring in the watch that he was working on out-of-round, out-of-flat, and out-at-the-collet. The students were then required to straighten the hairspring and only check with the instructor if they encountered some difficulty, otherwise the instructor was to examine the work only after it was completed.

July 17 to July 21

A lecture was given to the students on the evolution of the self-winding watch along with an explanation of the function of the various parts in an automatic mechanism. The students were then issued an A. Schild 1580 automatic watch to disassemble, clean, and reassemble. As each part was removed, the students were informed of the function of the part. At this point, the names of the parts were given to the students and the many repair aspects of automatic mechanisms were discussed. When the students had completed disassembling, cleaning, assembling, and oiling the automatic mechanism they were required to repeat the procedure. When the students completed this task satisfactorily, they were then given an A. Schild 1361 automatic to work on. The same procedure was followed with the AS 1361 as was previously followed with the AS 1580 automatic. The students were then required to work on an Etta 2375 automatic. This time it was required that the student disassemble not only the automatic mechanism, but the watch mechanism as well, and to clean and completely overhaul the movement. This full week of training was spent in working and studying automatic mechanisms. In addition, the students were informed of the wind-up indicating mechanism that is used on some automatic watches and how this mechanism operates.

July 24

The students were given a lecture on the proper procedure to follow in closing holes. It was especially pointed out that in automatic watches the barrel arbor bearings sometimes wear vary badly and must be closed. Also, the students were informed that especially on seven jewel watches, where there are no jewel bearings used in the train, the bearing holes very often will wear badly and must be closed or new bushings replaced. It was brought out that ordinarily a watchmaker would not perform this task often as most watchmakers will not accept seven jewel watches for repair. The students were further informed as to the method of determining the worn area of a bearing hole, the proper punches that

are used to close the hole, how the hole should be reamed to fit the pivot, proper burnishing of the hole, and how to remove any burrs that may appear around the hole due to the broaching procedure, et cetera. The students were then required to watch a demonstration of hole closing. At this point, the students were then instructed to proceed and close the upper and lower bearing holes of the barrel arbor and to close the upper and lower bearing holes in the barrel in accordance with the procedure previously outlined.

July 25

A demonstration was given to the students on the proper procedure to follow in closing the holes in train wheel bearings. The students were then required to close a hole on a plate that was issued to them for that purpose. We were especially interested to see that the students broached the holes properly and it was pointed out to the students how the wheel, when fitted into its proper position, should tilt out of upright the same amount in each direction.

July 26, 27, and 28

The students were given a lecture on the proper procedure to follow in handling each type of situation that can occur when various types of screws are damaged, rusted into position, broken off, et cetera. The students were informed of the proper use of the screw extracting tool, the method of driving out broken screws, the procedure for making a tap from screws, the procedure for dissolving a screw by boiling it in alum and water. It was explained to the students why ratchet screws are so often found broken and in fact can easily be broken if the screwdriver is not used properly when tightening a ratchet screw. The method of re-slotting certain screws to extract them was discussed. In addition, the handling of eccentric studs to tighten them and proper procedure for removing them was discussed, and last, the proper procedure to follow to remove broken balance wheel screws was covered. In the three-day period the students experienced and worked with each of the situations mentioned above and were quite capable of handling just about every situation that one is likely to encounter even to the extent of making taps and replacing oversized screws when necessary.

July 31

The students were given a lecture on the proper procedure to follow in fitting waterproof crowns, dustproof crowns, and dress crowns. The students were informed of the procedure to follow to determine the proper length of the stem, shortening the stem, and the procedure of securing the crown to the stem so that it will not loosen. The diameter of crowns in relation to the case was discussed and special attention was directed toward the proper ordering of all types of crowns. The students were then required to go through the procedure of fitting a crown to a watch.

August 1

The students were given a demonstration of jewelry polishing, cleaning watch cases, and tightening bows. A lecture was given to the students, at this point, on the fitting and selecting of proper spring bars. The students were then required to use the buffing machines to polish various articles and to ultrasonically clean these items.

August 2

The students were given a lecture on the waterproofing of watches. All the various aspects of this subject were covered including the use of various types of waterproof testing units, the FTC regulations, et cetera. The students were then required to run a waterproof watch through the waterproof testers and to make a close examination of the gasket in the case and the crown. Special attention was given to the tubes on waterproof cases and how they should be replaced.

August 3

The students were given a talk on the proper method of ordering watch parts. A complete review of the Best Fit catalog was made. The students were then required to look up dozens of parts for watch calibers that the instructor requested. The students were informed that for the next week we would spend about 15 or 20 minutes each morning discussing the ordering of watch parts. The remainder of the day was spent in covering small subjects dealing with the hands and dial of a watch. In this respect, the students were informed of the proper procedure of cleaning dials, selection of hour wheel washer, and fitting and adjusting hands.

August 4

The students were required to fit and adjust hands. A lecture and demonstration was then given to the students on the proper procedure to follow in centering dials on watches, tightening Swiss dial feet, and replacing a dial foot.

August 7

The students were given a lecture on various methods of tightening cannon pinions in watches. The various types of cannon pinions used in watches, including the off-center cannon pinion, were discussed. The students were then required to use each of the procedures covered in the lecture. The instructors also explained and demonstrated to the students the proper procedure to follow to loosen a cannon pinion that is too tight. Each student tightened a cannon pinion using the staking set, side cutters, end cutters, and special cannon pinion tightening tool.

August 8, 9 and 10

Lectures were given to the students concerning electric and electronic watches. A slide film on Accutron was presented to the students during this period and the students had an opportunity to examine and work with these various electric and electronic mechanisms.

August 11

A slide film on chronograph repairing was presented to the students. The students were then required to examine and make adjustments on a chronograph mechanism and to study the names of the various parts.

August 14 to August 31

A complete review of the entire curriculum was covered during this period. Every subject which was previously covered was required to be repeated by the students; staffing, truing, poising, resetting the escapement. We simply started at the beginning of the curriculum and had the students repeat each phase of work while they were engaged at the same time in overhauling watch movements. The instructors would damage curb pins, guard pins, roller jewels, et cetera, on practice work so that a student could not complete an overhaul without covering a certain portion of the curriculum. We proceeded in this way throughout this period and this brought about a complete practical review of all subjects taught. During this period we were especially concerned with position adjustment and isochronism and lectured on this subject each morning during this period of training. During this period the students were required to use a filing fixture in filing stems and to repeat all phases of previous machine work.

APPENDIX A

**DISASSEMBLY AND ASSEMBLY PROCEDURE
PROGRAMMED INSTRUCTION BOOKLET**

DISASSEMBLY AND ASSEMBLY
PROCEDURE OF THE

A. SCHILD 1525 - 10 1/2 LIGNE 23.69 mm.
1526 - 11 1/2 LIGNE 25.94 mm.

MOVEMENT

BY

WILLIAM O. SMITH, JR.

GRAY LAWRENCE

HUGH G. WALES, PH.D.

LESSON ONE

WATCH TECHNICIAN
AND
MICRO-PRECISION TECHNOLOGY

UNIVERSITY OF ILLINOIS
URBANA, ILLINOIS

PREFACE

A publication of this type not only involves the collection and organization of a substantial amount of technical material, but in addition it gives one an opportunity to utilize sound instructional techniques found in modern educational literature.

The earlier works of William O. Smith, Sr., and William O. Smith, Jr., did an exceptionally fine job of organizing a variety of technical presentations found in their internationally recognized ESEMBL-O-GRAPH. Hence, this present publication gives full recognition to the significant contributions which these two men have made to educational materials of this type.

The present volume is a revision of earlier work done by Messrs. Smith and incorporates the latest methods of programmed instruction to facilitate its use in the instruction of students who are preparing themselves to become watch technicians.

Throughout this book there is one change in terminology which gives recognition to the new relationship and status of those who are preparing themselves for the attractive and dynamic opportunities that await highly skilled technicians, namely, the term "watch technician" instead of "watchmaker". Watchmaker is no longer a realistic term, as everyone knows. Instead, the term watch technician or horological technician more adequately describes the advanced technical skills possessed by those who have attended modern technical schools giving instruction in various aspects of work related to time-measuring devices.

No work of this type can be produced without a substantial amount of help from a variety of sources--personnel, industry and educational resources. The authors wish to express their appreciation particularly to Jerome W. Robbins, President of the Elgin National Watch Company, and Donald W. Leverenz, Director of Technical Trade Relations of the Elgin National Watch Company, for the watch movements which they made available for use and for the technical assistance which they gave; to members of the Industry Advisory Board of the American Watchmakers Institute for the encouragement which they have provided; and to Mrs. Charlotte Mayne and Mrs. Mary Wales for typing the manuscript and preparing the copy for printing.

The methods used in this book can be applied to any standard movement of similar design irrespective of the company or country of origin. Hence, the fact that this book is based upon two well-known movements (AS 1525 and AS 1526) imported by the Elgin National Watch Company should in no way be construed as a recommendation or approval of these particular movements.

Additional educational materials involving various types of movements and equipment will be published from time to time in this series, and the same educational principles will apply in the discussion of these items.

Urbana, Illinois
February, 1967

HUGH G. WALES
Supervisor
Watch Technician Program

INSTRUCTIONS FOR
THE USE OF THIS BOOK

This book gives detailed instructions for the disassembly and the assembly of the Elgin Model 874 watch (AS 1525, 10 1/2 ligne, 23.69 mm. and AS 1526, 11 1/2 ligne, 25.94 mm.). There are a good many watches of similar design which can be disassembled and assembled by using the same procedure as outlined here.

DISASSEMBLY OF THE ELGIN 874 WATCH

When disassembling the watch, remove each part according to the sequence outlined in this book. The first part to be removed is Part No. 1, illustrated on page 1-A. The second part to be removed is Part No. 2, illustrated on page 2-A, and so on until the disassembly is completed.

When removing each part, using the above sequence, proceed as follows:

1. Observe the drawing of the part to be removed. This drawing is usually found at the top of each illustration page. The purpose of this drawing is:
 - A. To identify the part to be removed.
 - B. To indicate certain reference points on the part.
2. On the lower half of each illustration page is a photograph of the watch. In this photograph the part to be removed is identified and clearly shown in the exact position it occupies in the watch.
3. When the part is located in the watch, read the text that explains:
 - A. The removing procedure.
 - B. The hazards in removing, if any.

(The above text is found on the page opposite the illustration page.)

4. Remove the part, following the instructions in the text.
5. Turn to the next page in the book and remove the next part, following the same procedure. Continue this procedure until all the parts illustrated in this book are removed from the watch.

ASSEMBLY OF THE ELGIN 874 WATCH

The assembly of the watch is exactly the reverse of the disassembly. The first part to be replaced is Part No. 16. The second part to be replaced is Part No. 15, and so on until assembly is completed.

When replacing each part, using the above sequence, proceed as follows:

1. Observe the drawing of the part to be replaced. The purpose of this drawing is:
 - A. To identify the part to be replaced.
 - B. To indicate certain reference points on the part.
2. On the lower half of each illustration page is a photograph of the watch. In this photograph the part to be replaced is identified and clearly shown in the exact position that it occupies in the watch.
3. Before replacing the part in its proper position in the watch, read the text that explains:
 - A. The replacing procedure.
 - B. The hazards in replacing, if any.
 - C. The function of each part.

(The above text is found on the page opposite the illustration page.)

4. Replace the part, following the instructions in the text.
5. After the first part is replaced, turn to the preceding page in the book, and replace the next part, following the same procedure. Continue this until all the parts illustrated in this book are replaced in the watch.

REMOVING THE HANDS

The hour hand of a watch is fitted friction tight to the pipe of the hour wheel. The minute hand is fitted friction tight to the cannon pinion.

Before removing the hands, pull the crown out to setting position and move the minute hand directly over the hour hand. Now place the hand removing tool on the dial, in the position shown in Figure 1, with the jaws "A" under the base of the hour hand "F". Apply a light pressure to the sides "C" of the hand remover. This will force the jaws "A" to contact the pipe of the hour hand and the part "B" of the hand remover to contact the top of the minute hand "E". While holding the hand removing tool perfectly upright, apply a stronger pressure to the sides "C". This will force the jaws "A" to move up, pulling the hour hand and minute hand with it.

The second hand of the watch is fitted friction tight to the long pivot of the fourth wheel. The tube of the second hand is usually quite long, because it must reach to the pivot, which is generally below the level of the dial.

To remove the second hand, use the hand remover. Be careful in sliding the jaws under the second hand that they do not scratch the dial. For removing the second hand, the hand remover is used in the same way as explained above in removing the hour and minute hands.

HAZARDS IN REMOVING THE HANDS

Care must be taken not to allow the jaws of the hand remover to scratch the dial. To avoid scratching the dial, some watchmakers slide a dial protector under the hands before using the hand remover.

REPLACING THE HANDS

Second Hand: Place the hole in the tube of the second hand over the long pivot of the fourth wheel. Now with a pair of tweezers, press the hand down as close as possible to the dial, with assurance that there is still enough clearance between the dial and the second hand that it will at no time touch.

Hour Hand: Place the hour hand over the hour wheel tube. The hour hand should be pointing to 12 o'clock. Now with a pair of tweezers, press the hour hand down until the top of the hour hand is level with the top of the hour wheel tube.

Minute Hand: Place the hole in the minute hand over the cannon pinion. The minute hand should be directly over the hour hand, also pointing to 12 o'clock. Now with the back of a pair of tweezers, press the minute hand down until the top of the minute hand is level with the top of the cannon pinion.

Now pull outward on the stem to setting position, and turn the hands several revolutions to see that the hands do not touch and that there is equal clearance between the second hand and the dial, between the second hand and the hour hand, and between the hour hand and the minute hand.

HAZARDS IN REPLACING THE HANDS

Do not exert any greater pressure on the center post than is necessary to force on the minute hand. If too much pressure is applied on the center post, there is danger that the center jewel may be crushed or forced out of the plate.

REFERENCE POINTS

- A - Hand lifting jaws
- B - Center hand retaining spring post
- C - Side springs for pusher blocks
- E - Minute hand
- F - Hour hand

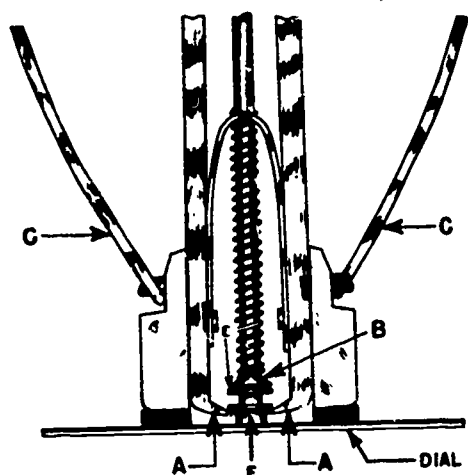

HAND REMOVING TOOL

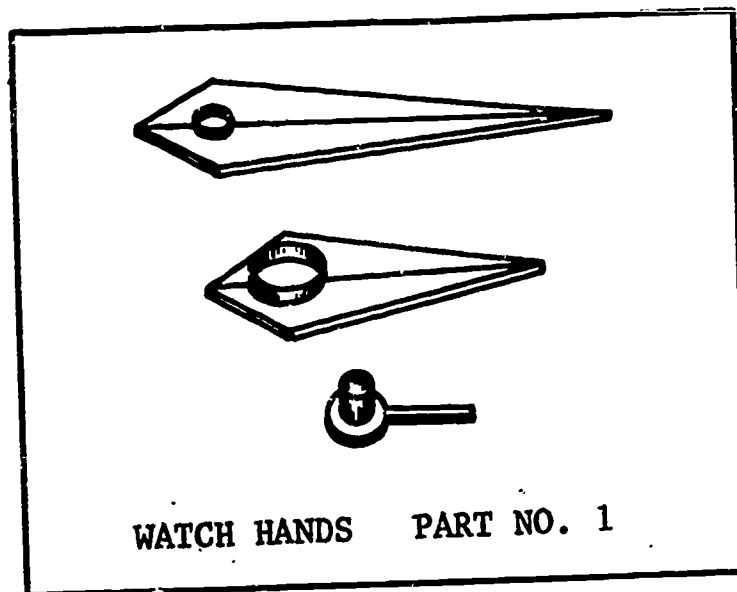
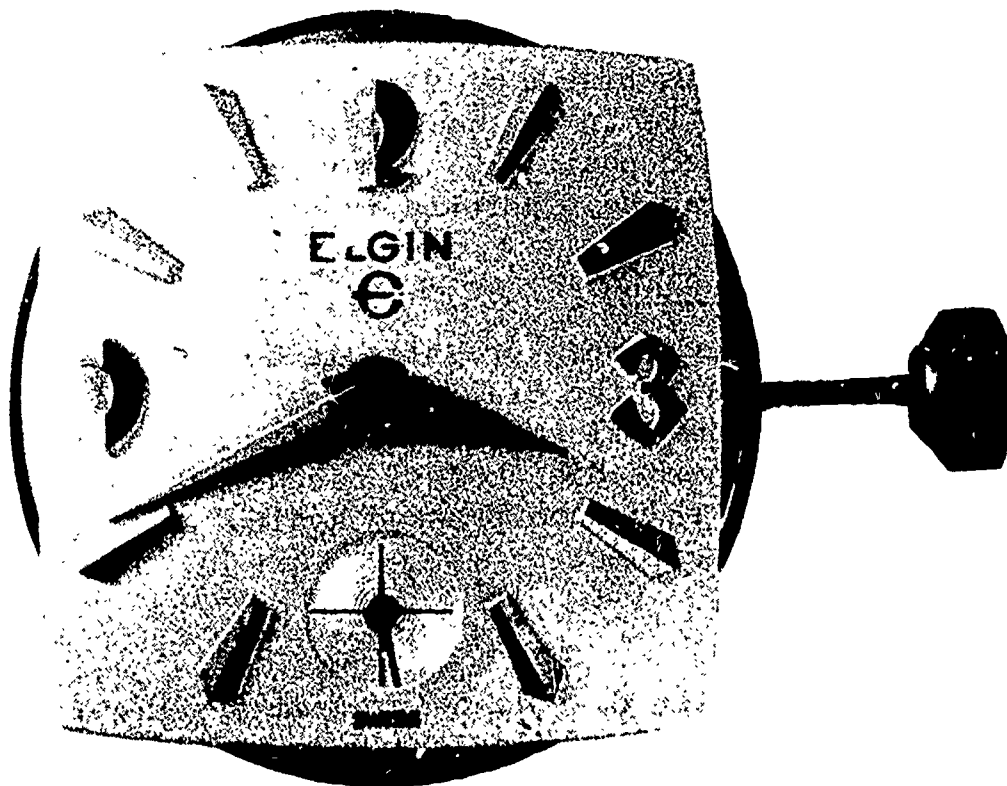

FIG. 1



1-A

REMOVING THE DIAL

The dial is held to the watch movement by means of two dial feet shown as "B" in Figure 2. When the dial is on the watch, these two dial feet are held in place by the two screws which are located at positions "C" on the outside edge of the watch.

To remove the dial, these two identical screws located on the outside edge of the watch must be loosened. These screws do not have to be removed. Just loosen the screws enough that the dial feet are free in the holes in the plate. When this is done, lift the dial from the movement by sliding a case opener between the dial and plate near one of the dial feet. Just slide in the case opener far enough to lift the dial slightly. Then move the case opener to the position of the other dial foot and lift the dial slightly. This should be repeated until the dial feet are free from the holes in the plate. The dial can then be lifted from the movement. Now tighten the dial screws to prevent the loss of these screws during the servicing operations and cleaning.

HAZARDS IN REMOVING THE DIAL

If the dial cannot be raised easily, find out what is holding it. It may be that one of the dial screws is still holding one of the dial feet and needs to be loosened a turn or two farther. Also, if the dial is not kept level when removing it, the dial feet will bind in the holes, preventing the dial from being removed and increasing the danger of damaging the dial if too much force is applied.

REPLACING THE DIAL

To replace the dial, loosen the two dial screws "C" a sufficient distance so that they cannot be seen protruding into the holes for the dial feet. The dial screws are located on the outside edge of the watch. When the screws are loosened, the dial is placed on the movement in a position that will place the hole "A" in the dial directly over the elongated fourth wheel pivot. (If the number 3 on the dial is placed in line with the winding stem of the watch, the second hand hole will be in the proper position over the fourth wheel pivot.) With the dial in its proper position, it may be gently pressed down in place, and the two dial screws can be tightened to hold the dial securely.

HAZARDS IN REPLACING THE DIAL

Keep the dial level when pressing it down into its proper place, because any tilting will cause the dial feet to bind in the holes, preventing the dial from being pressed down flush on the plate. Also, be very careful to position the dial feet in the dial holes, because the dial feet can cause considerable damage if they should be pressed against the balance wheel, pallet fork, or train wheel by accident.

FUNCTION OF THE DIAL

The function of the dial is to provide a scale for the hands to indicate the time of day. The dial also holds the hour wheel down in its proper position. A tension washer (dial washer) acts as a device to exert constant light pressure on the hour wheel so that it will always engage the teeth of the minute wheel pinion.

REFERENCE POINTS

- A - Hand lifting jaws
- B - Center hand retaining spring post
- C - Side springs for pusher blocks
- E - Minute hand
- F - Hour hand

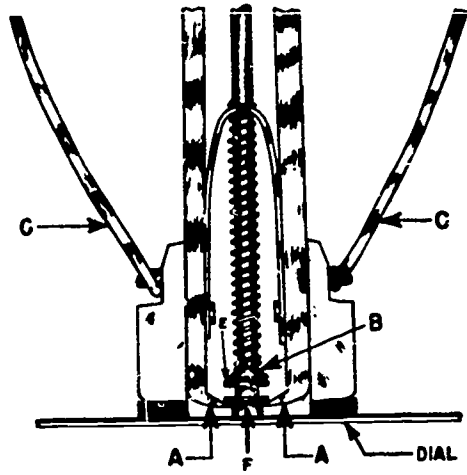

HAND REMOVING TOOL

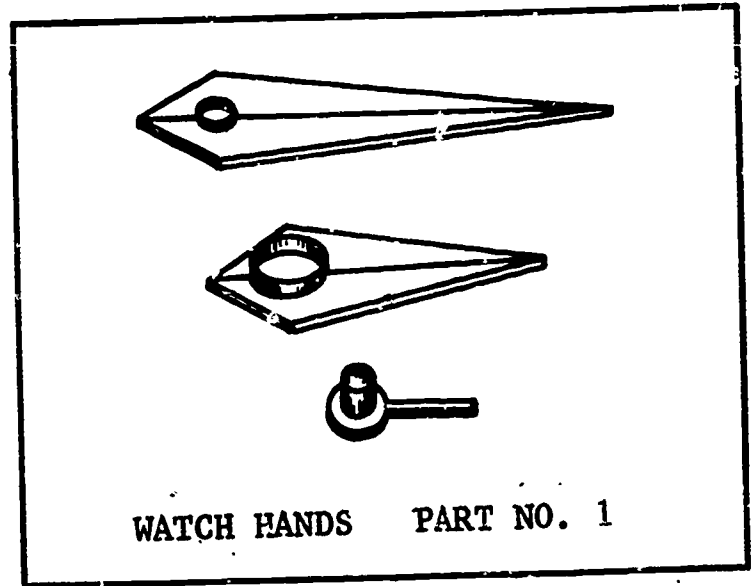

WATCH HANDS PART NO. 1

FIG. 1

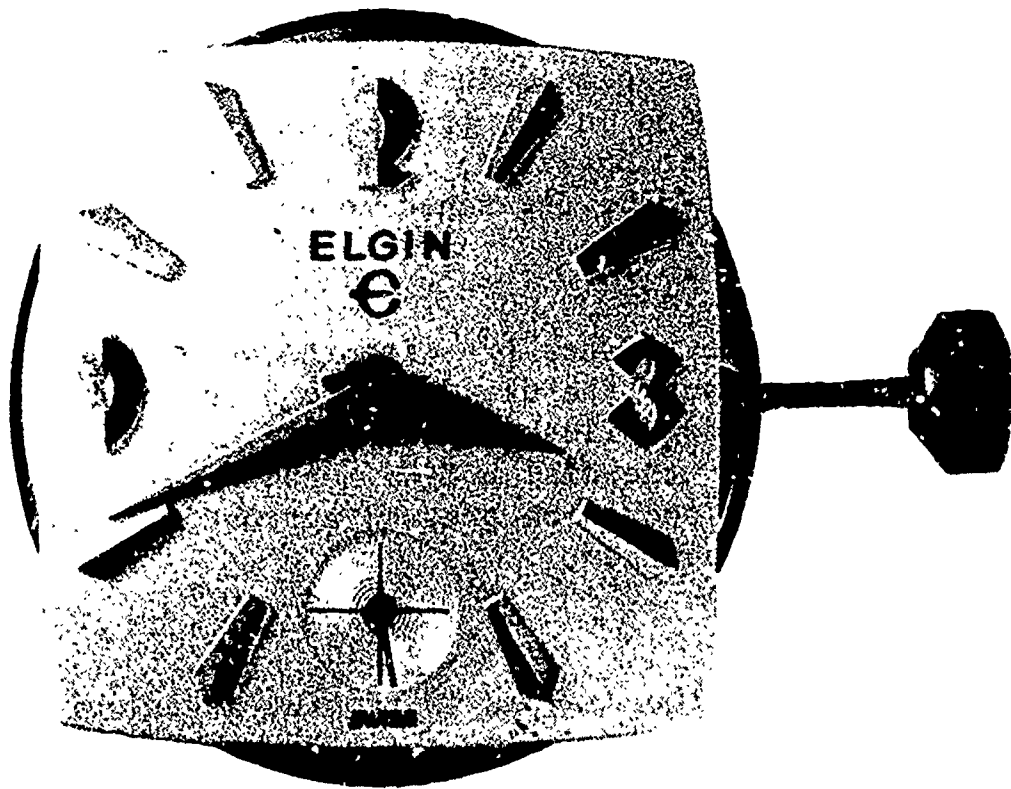

1-A

REMOVING THE DIAL

The dial is held to the watch movement by means of two dial feet shown as "B" in Figure 2. When the dial is on the watch, these two dial feet are held in place by the two screws which are located at positions "C" on the outside edge of the watch.

To remove the dial, these two identical screws located on the outside edge of the watch must be loosened. These screws do not have to be removed. Just loosen the screws enough that the dial feet are free in the holes in the plate. When this is done, lift the dial from the movement by sliding a case opener between the dial and plate near one of the dial feet. Just slide in the case opener far enough to lift the dial slightly. Then move the case opener to the position of the other dial foot and lift the dial slightly. This should be repeated until the dial feet are free from the holes in the plate. The dial can then be lifted from the movement. Now tighten the dial screws to prevent the loss of these screws during the servicing operations and cleaning.

HAZARDS IN REMOVING THE DIAL

If the dial cannot be raised easily, find out what is holding it. It may be that one of the dial screws is still holding one of the dial feet and needs to be loosened a turn or two farther. Also, if the dial is not kept level when removing it, the dial feet will bind in the holes, preventing the dial from being removed and increasing the danger of damaging the dial if too much force is applied.

REPLACING THE DIAL

To replace the dial, loosen the two dial screws "C" a sufficient distance so that they cannot be seen protruding into the holes for the dial feet. The dial screws are located on the outside edge of the watch. When the screws are loosened, the dial is placed on the movement in a position that will place the hole "A" in the dial directly over the elongated fourth wheel pivot. (If the number 3 on the dial is placed in line with the winding stem of the watch, the second hand hole will be in the proper position over the fourth wheel pivot.) With the dial in its proper position, it may be gently pressed down in place, and the two dial screws can be tightened to hold the dial securely.

HAZARDS IN REPLACING THE DIAL

Keep the dial level when pressing it down into its proper place, because any tilting will cause the dial feet to bind in the holes, preventing the dial from being pressed down flush on the plate. Also, be very careful to position the dial feet in the dial holes, because the dial feet can cause considerable damage if they should be pressed against the balance wheel, pallet fork, or train wheel by accident.

FUNCTION OF THE DIAL

The function of the dial is to provide a scale for the hands to indicate the time of day. The dial also holds the hour wheel down in its proper position. A tension washer (dial washer) acts as a device to exert constant light pressure on the hour wheel so that it will always engage the teeth of the minute wheel pinion.

REFERENCE POINTS

- A - Second hand hole
- B - Dial feet
- C - Location of dial screws

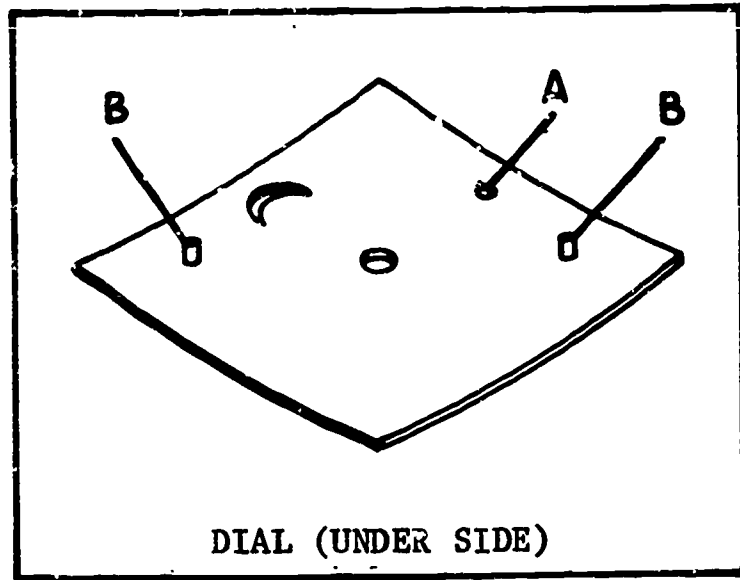
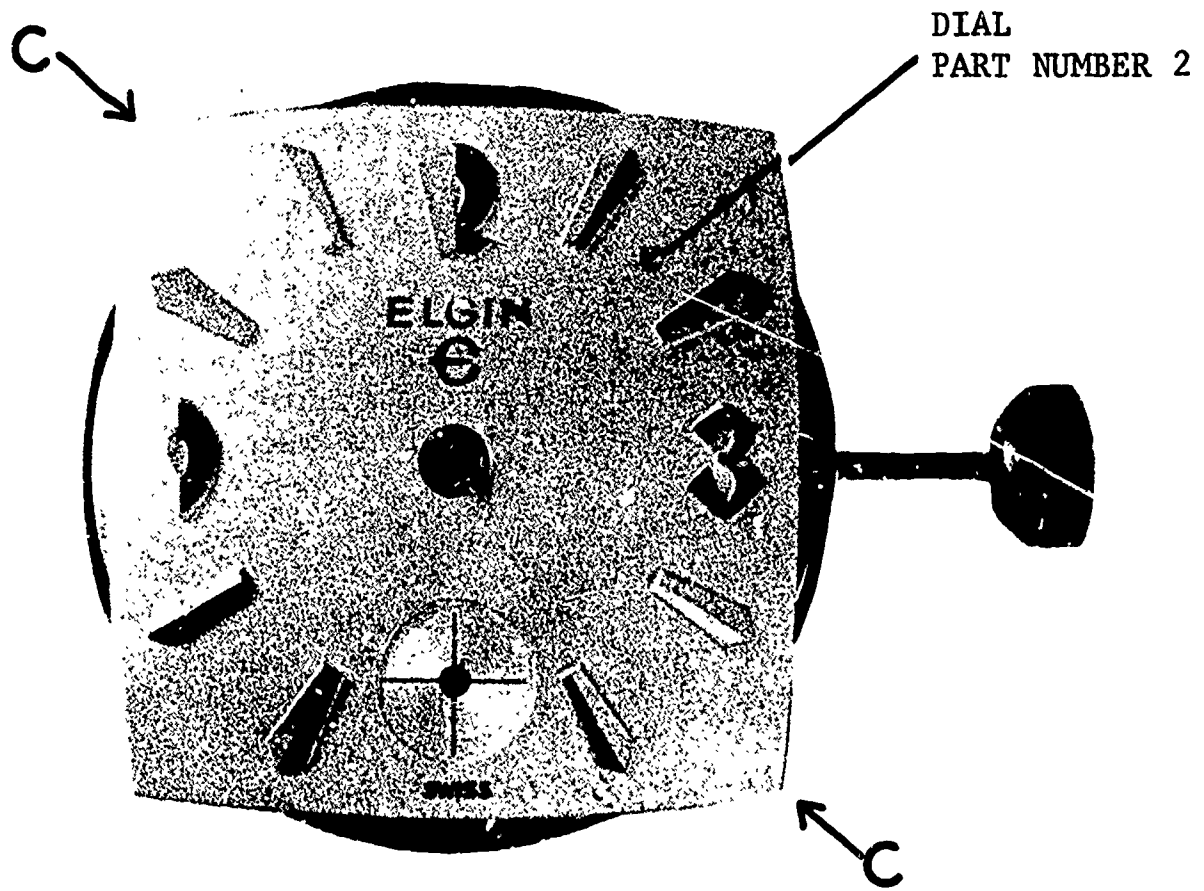

FIG. 2



2-A

REMOVING THE HOUR WHEEL

To remove the hour wheel, grip the tube "A" on the hour wheel with a pair of tweezers and lift this wheel straight up off the cannon pinion. This wheel should be free on the cannon pinion, so there should be no difficulty in removing this part.

REPLACING THE HOUR WHEEL

Place the hour wheel in its proper position, as shown in Figure 3. The tube "A" on this wheel should be up, and the hole in the hour wheel should fit over the cannon pinion. Now lower the hour wheel so that the teeth on the hour wheel mesh with the leaves on the minute wheel pinion. The hour wheel should be free enough on the cannon pinion that it can turn without binding.

FUNCTION OF THE HOUR WHEEL

The function of the hour wheel is to rotate at a rate that will indicate the hours on the dial. This is done by means of a hand attached to the tube on this wheel. One complete revolution of the hour wheel denotes that twelve hours have elapsed.

REMARKS

The dial train of a watch consists of the following parts: cannon pinion, minute wheel, and hour wheel.

The dial train wheels and pinions in this watch have the following number of teeth or leaves:

- Cannon pinion 10 leaves
- Minute wheel 30 teeth
- Minute pinion 8 leaves
- Hour wheel 32 teeth

Notice the 3 to 1 ratio between the minute wheel and the pinion with which it meshes (the cannon pinion), and the 4 to 1 ratio between the hour wheel and the pinion with which it meshes (the minute pinion).

This allows for a 12 to 1 ratio between the hour wheel and the cannon pinion. Thus, the cannon pinion to which the minute hand is fitted makes 12 revolutions for every one revolution of the hour wheel to which the hour hand is fitted.



REFERENCE POINTS

- A - Hour wheel tube
- B - Hour wheel teeth

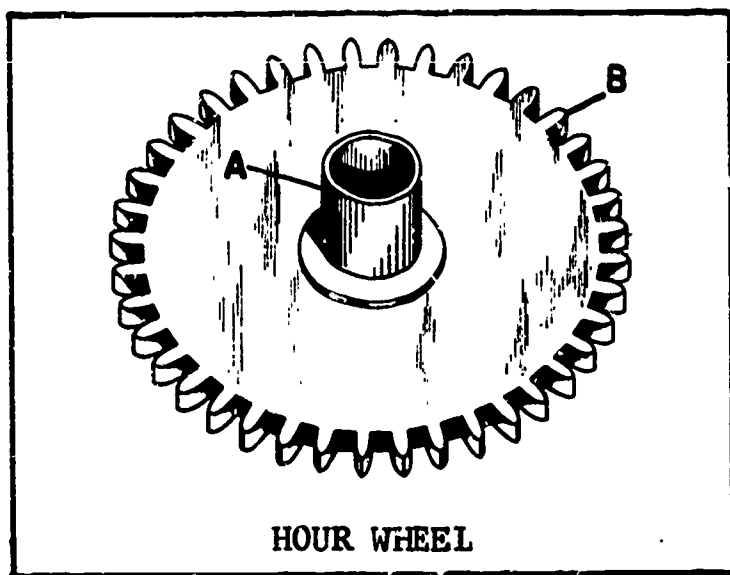

HOUR WHEEL

FIG. 3

HOUR WHEEL
PART NUMBER 3

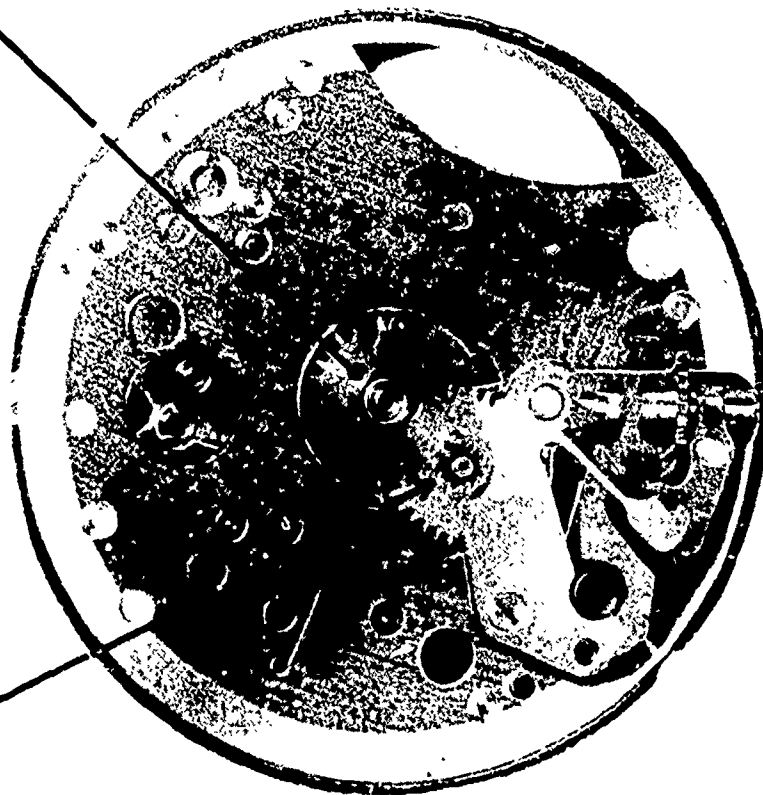

MINUTE WHEEL
PINION

3-A

REMOVING THE CANNON PINION

The cannon pinion can be removed with tweezers. This is done by gripping the cannon pinion with tweezers right under the top shoulder "A" on the pinion. Now lower the back of the tweezers until they touch the plate. The portion of the plate that the tweezers contact will act as a fulcrum for the tweezers to pivot on. Now press down on the back of the tweezers, being sure to squeeze the tweezers tightly, so that they do not slip over the shoulder of the cannon pinion. The cannon pinion is usually tight, so quite a bit of pressure may have to be exerted on the back of the tweezers in order to remove the cannon pinion. Press down on the back of the tweezers until the point of the tweezers and the cannon pinion are raised high enough that the cannon pinion is free from the center wheel post.

The cannon pinion can also be removed with a cannon pinion removing tool. This method should be reserved for only very tight cannon pinions. If the cannon pinion is difficult to remove with tweezers, consult the instructor for information about the proper use of the cannon pinion removing tool.

HAZARDS IN REMOVING THE CANNON PINION

In removing the cannon pinion with tweezers, it should be lifted straight up to prevent any bending or breaking of the center wheel post. Also, care should be taken when removing the cannon pinion that the tweezers do not touch the fourth wheel pivot. (The fourth wheel pivot is the pivot on which the second hand fits.)

REMARKS--IMPORTANT

This is the last part to be removed from the dial side of the watch. The movement must now be turned over and placed in a movement holder with the train side of the watch facing up. A movement holder is really nothing more than a small vice-like tool in which the jaws can be controlled by a screw. The movement is placed in the movement holder with the stem in a position that will clear the jaws. The jaws are then tightened just enough to hold the movement securely.

REPLACING THE CANNON PINION

The cannon pinion fits friction tight on the post of the center wheel. To replace the cannon pinion, grip the waist of the cannon pinion with the tweezers and place the hole in the pinion over the center wheel post. Be sure that the leaves "B" of the pinion are down. Now with a pair of tweezers, press the pinion down as far as it will go. The leaves "B" of the cannon pinion should mesh with the teeth of the minute wheel "C", as shown in Figure 4.

FUNCTION OF THE CANNON PINION

1. The cannon pinion transfers the power from the center wheel pinion to the dial train.
2. Because of the friction slipping arrangement of the cannon pinion, it is possible to set the hands to the correct time through the setting mechanism connected to the stem and crown of the watch.
3. The cannon pinion makes one revolution every hour. The cannon pinion is the part to which the minute hand is normally attached.

REFERENCE POINTS

- A - Top shoulder
- B - Leaves
- C - Minute wheel

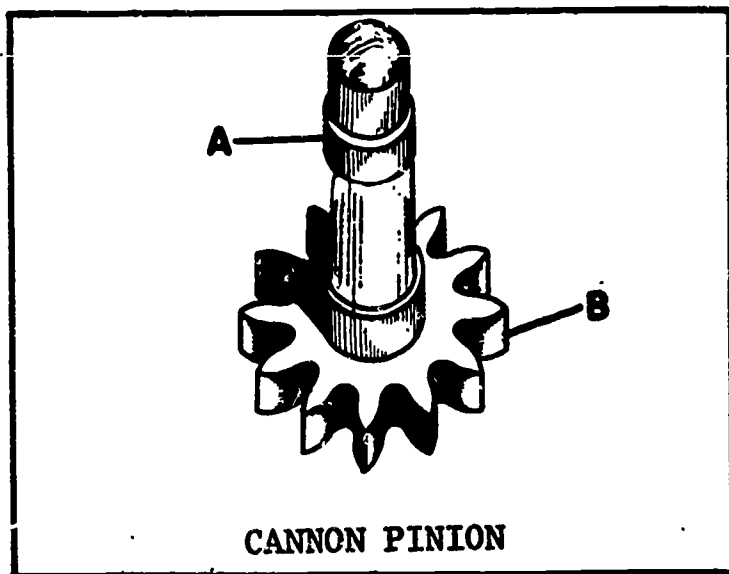
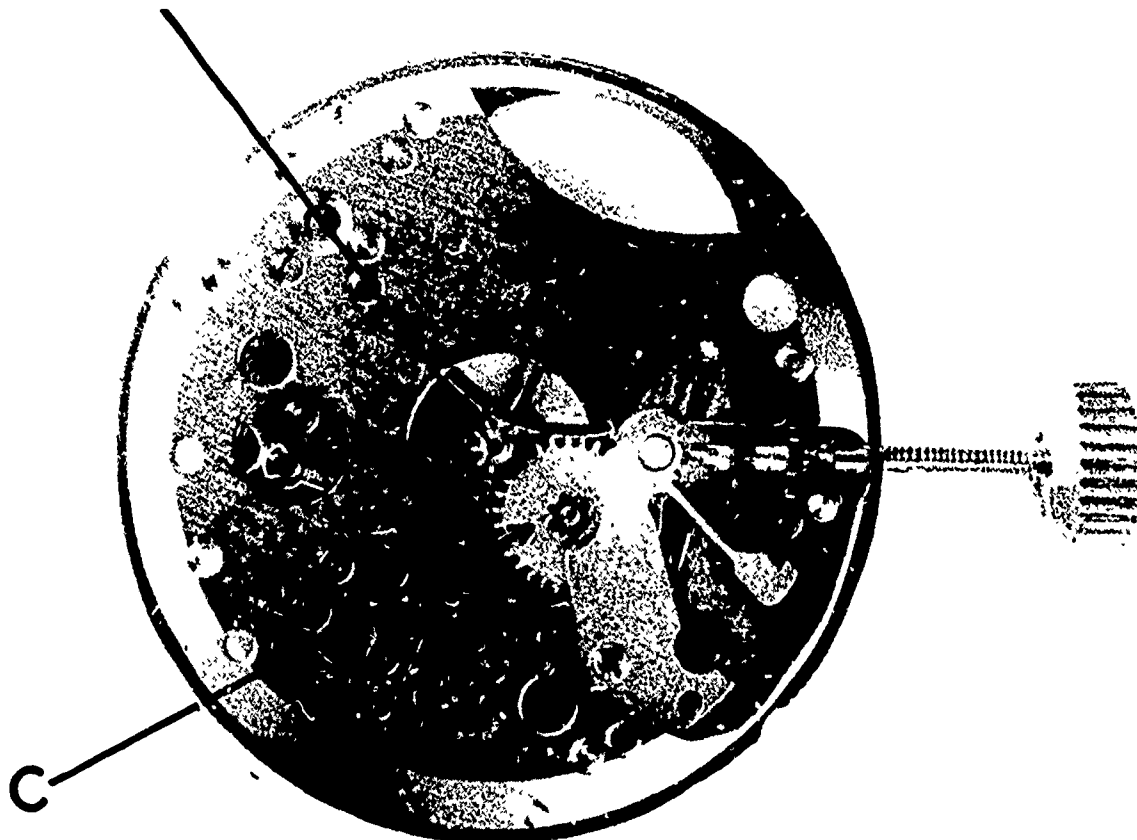

FIG. 4

CANNON PINION
PART NUMBER 4



4-A

REMOVING THE BALANCE ASSEMBLY

1. Place the movement on a movement holder with the train side up.
2. Remove the bridge screw that holds the balance bridge in place.
3. Slide a finely sharpened screwdriver into the notch under the balance bridge at location "H". Turn the screwdriver to raise the bridge; this will loosen the steady pins "J" from the holes in the plate.
4. Grasp the balance bridge at location "K" with a pair of tweezers. Lift up the bridge, until the steady pins on the bridge are level with the lower plate.
5. Now lift straight up on the bridge, until the bridge is about 1/4" above the plate. (Any higher than 1/2" will distort the hairspring.) Shake the watch slightly to help free the lower pivot from the jewel, and at the same time raise the balance bridge slightly higher.
6. When the weight of the balance wheel is supported by the hairspring, move the bridge in a direction to slide the balance wheel out from under the center wheel.
7. When the balance wheel is free of the watch, lay the bridge and balance wheel on the bench with the balance wheel on the bottom and the bridge resting on top of it. It will not be necessary to separate the balance wheel from the bridge.

HAZARDS IN REMOVING THE BALANCE ASSEMBLY

Make sure that the bridge is not lifted so high as to distort the hairspring. If difficulty is encountered in removing the balance assembly, simply put the bridge back in place and consult the instructor.

Be sure not to lift the balance bridge in a manner that will cause the hairspring to catch on the center wheel, because it will probably damage or distort the hairspring.

REMARKS

The balance assembly consists of the following parts:

1. Balance bridge
2. Hairspring
3. Balance wheel

REFERENCE POINTS

- H - Location of notch
in plate to receive
screwdriver
- J - Steady pins
- K - Location to grasp
bridge with tweezers

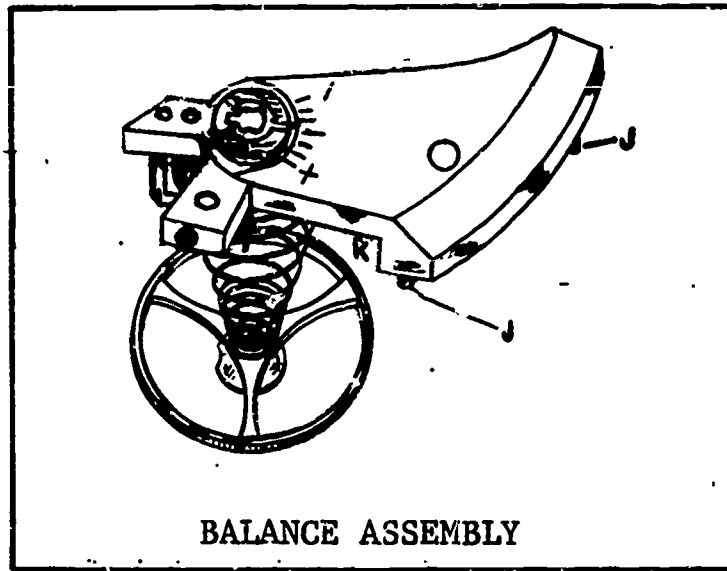
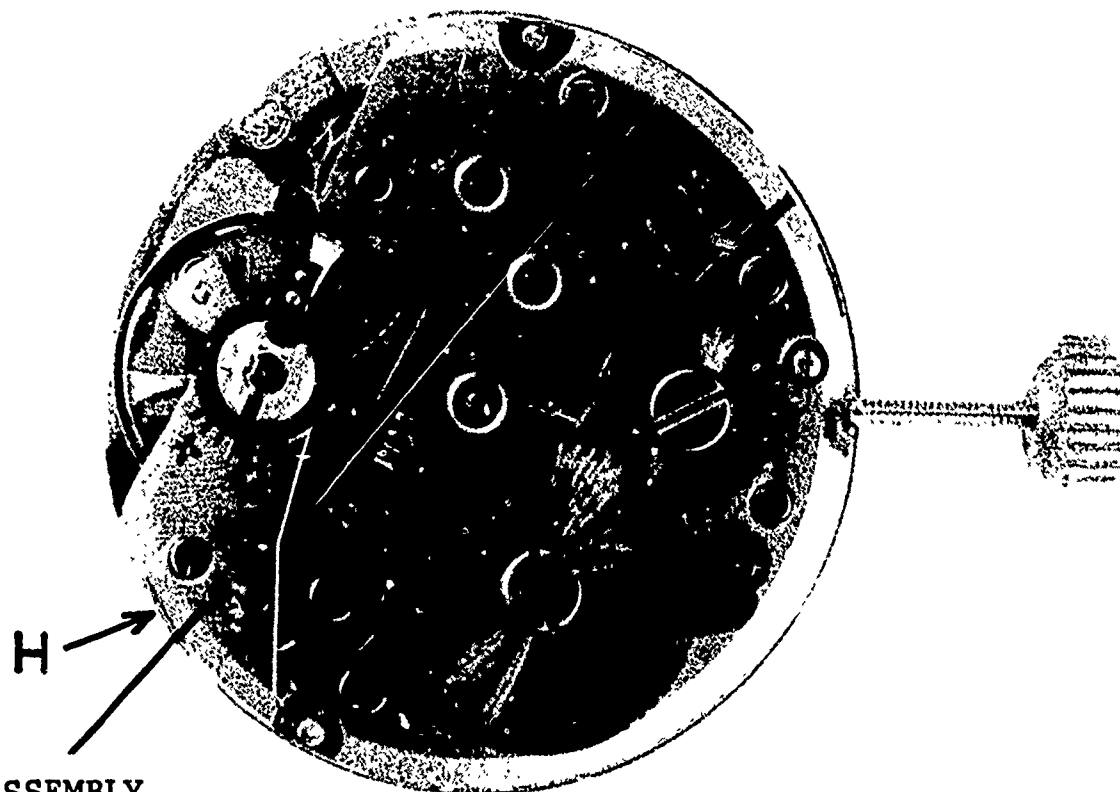

FIG. 5



BALANCE ASSEMBLY
PART NUMBER 5

5-A

THE INSTRUCTIONS ON THIS PAGE ARE FOR REPLACING THE BALANCE ASSEMBLY. DISREGARD THIS PAGE WHEN DISASSEMBLING THE WATCH.

REMARKS--IMPORTANT

One of the most important things that must be done when replacing the balance assembly is to replace the balance wheel in such a position that the roller jewel "F" will enter the slot "L" in the pallet fork. See Figures 5A and 5B. When the pallet fork is against the banking pin "M" as shown in Figure 5A, the balance wheel must be lowered into position, with the roller jewel "F" in a position so that when the balance wheel is turned counter-clockwise the roller jewel will enter the slot "L" of the pallet fork. If the pallet fork is resting against the banking pin "N" as shown in Figure 5B, the balance wheel will have to be lowered into position with the roller jewel "F" in such a position that when the balance wheel is turned clockwise, the roller jewel will enter the slot "L" of the pallet fork. (The roller jewel is set in the roller table located under the balance wheel.)

REPLACING THE BALANCE ASSEMBLY

Before replacing the balance assembly, wind the watch slightly by turning the winding crown a half turn in a clockwise direction, and be sure the pallet fork is against one of the banking pins. To replace the balance assembly, proceed as follows:

1. Grip the balance bridge at location "K" with a pair of tweezers.
2. Raise the balance bridge off the bench until the hairspring will support the weight of the balance wheel.
3. While holding the bridge in this manner, move the balance assembly over the watch and slide the balance wheel under the center wheel.
4. Lower the bridge so that the balance wheel lower pivot can enter the jewel hole in the plate.
5. Make sure that the roller jewel "F" is in the correct position in relation to the pallet fork.
6. Turn the bridge until the steady pins on the bridge are directly over the holes for the steady pins in the plate.
7. Lower the bridge, making sure that the hairspring does not catch on the center wheel.
8. Check to see that the steady pins on the bridge are entering the proper holes in the plate. Then push the bridge down to the proper place, making sure the top pivot of the balance staff is entering the jewel hole in the bridge.
9. Replace the bridge screw that holds this bridge in place.

HAZARDS IN REPLACING THE BALANCE ASSEMBLY

When pushing the bridge down to the proper place, make sure that the top pivot of the balance staff is entering the pivot hole in the bridge. Otherwise, the pivot may be bent or broken.

In servicing a watch, this is the last part to be replaced on the train side of the watch. Now lift the watch from the movement holder and turn it over. Place the movement on a clean piece of watch paper on the desk, with the dial side facing up. If one wishes, the dial and hands can now be replaced.

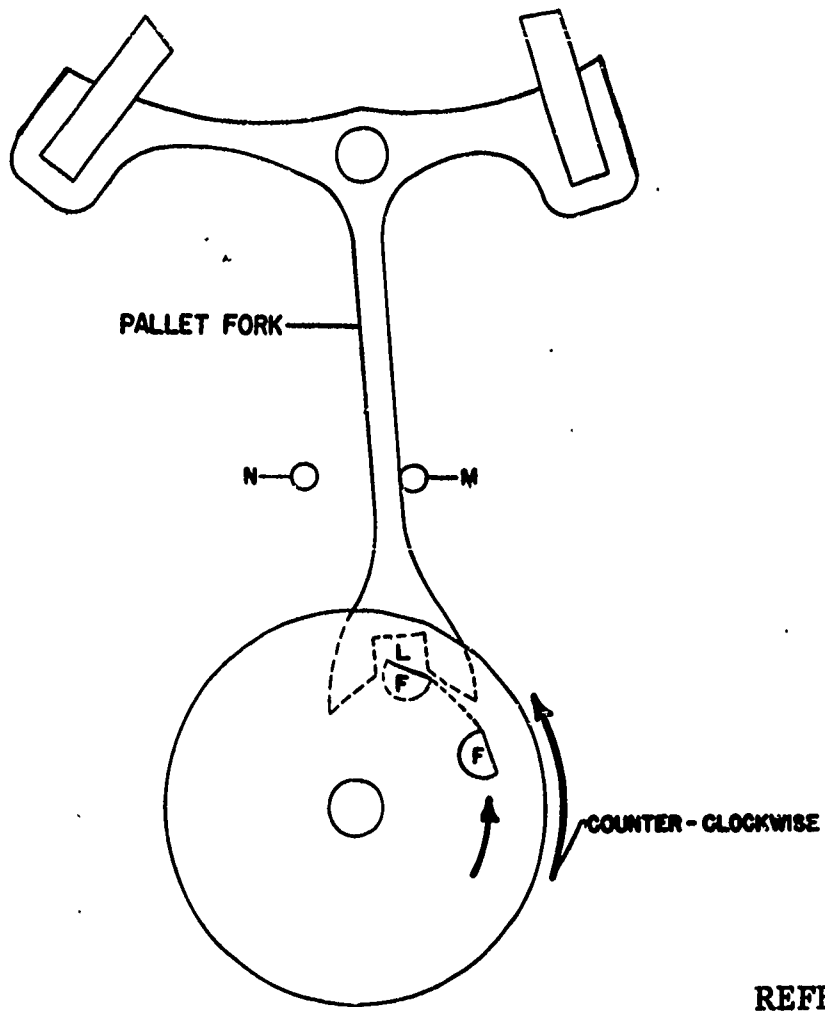

FIG. 5A

REFERENCE POINTS

- F - Roller jewel
- L - Slot in pallet fork
- M - Right banking pin
- N - Left banking pin

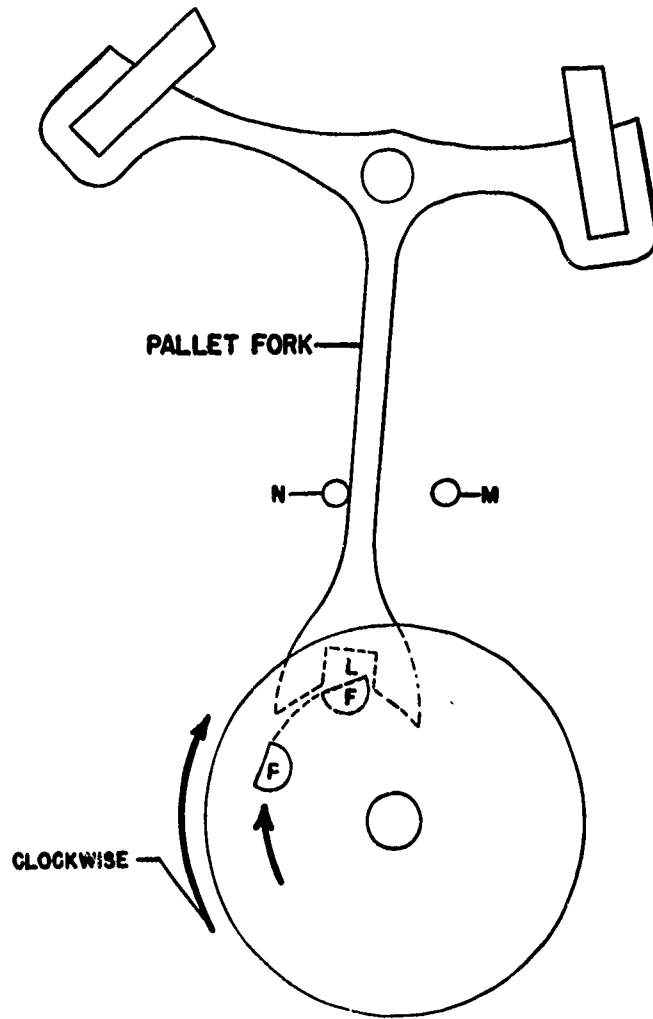

FIG. 5B

5-C

PREPARATION FOR REMOVING THE PALLET BRIDGE

IMPORTANT: LET DOWN THE MAINSPRING POWER

Before proceeding, the mainspring power must be released. To accomplish this, proceed as follows:

1. Grip the crown between the forefinger and thumb as if to wind the watch.
2. Turn the crown slowly and observe the action of the "click" on the ratchet wheel teeth.
3. When the click on the ratchet wheel is forced out from between the teeth of the ratchet wheel, take a small screwdriver and push the click completely out of engagement with the wheel.
4. While holding the click in this position, turn the crown slowly to let down the power of the mainspring. Do not let the mainspring power spin down quickly but release it slowly to prevent damage from occurring.

REMOVING THE PALLET BRIDGE

To remove the pallet bridge, remove the bridge screw which holds this bridge in place. Now slide a finely sharpened screwdriver between the base of the bridge and the plate at location "C" and turn the screwdriver. This will raise the bridge, loosening the steady pins in the bridge from the holes in the plate. After the bridge is loosened from the plate, lift the bridge out of place with a pair of tweezers.

HAZARDS IN REMOVING THE PALLET BRIDGE

When sliding the screwdriver under the bridge to raise the bridge, care should be taken to keep the bridge level, because any twisting of the bridge may damage the pivot on the pallet fork.

REPLACING THE PALLET BRIDGE

Place the bridge in position on the plate as shown in Figure 6. Check to see that the steady pins "A" on the bridge are entering their proper holes in the pillar plate. Now press the bridge down lightly with a piece of pegwood until the bridge lightly touches the pallet fork's top pivot. Now, with a pair of tweezers, move the fork slightly until the top pivot enters the jewel hole in the bridge. The bridge can now be pressed down to the proper place, and the bridge screw can be replaced. After the bridge is replaced, check to see that the pallet fork pivots freely.

FUNCTION OF THE PALLET BRIDGE

The function of this bridge is to hold the pallet fork in position and to provide a bearing for the upper pivot of the pallet fork.

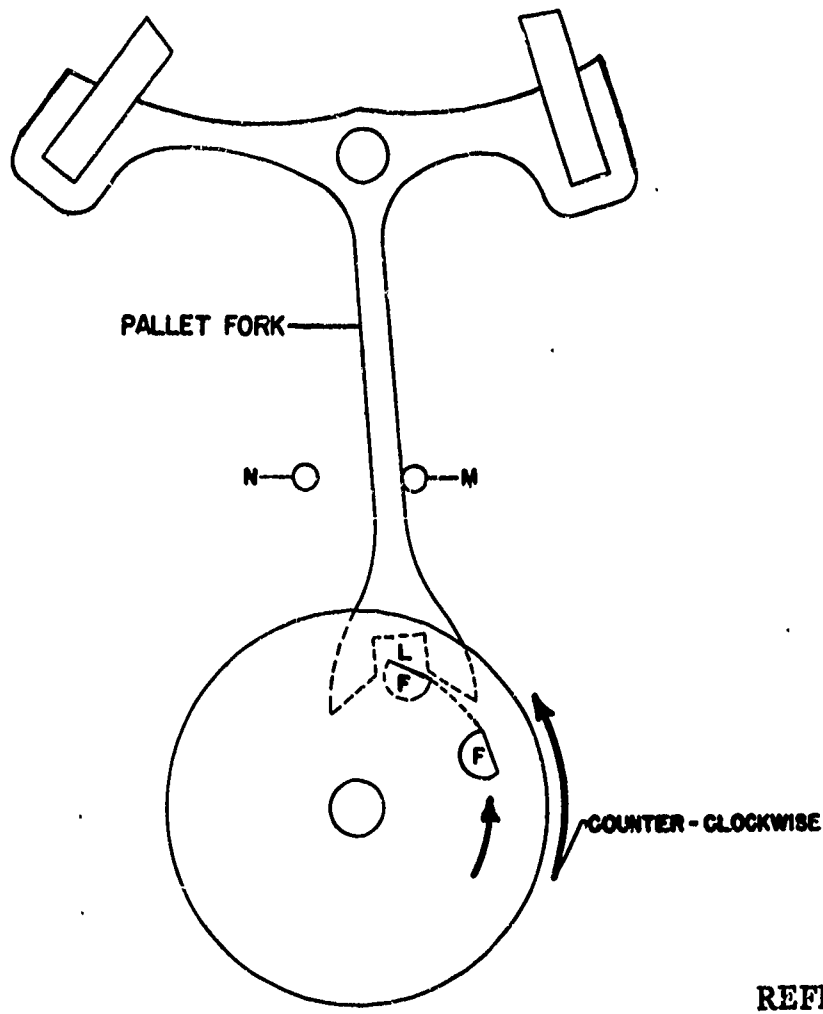

FIG. 5A

REFERENCE POINTS

- F - Roller jewel
- L - Slot in pallet fork
- M - Right banking pin
- N - Left banking pin

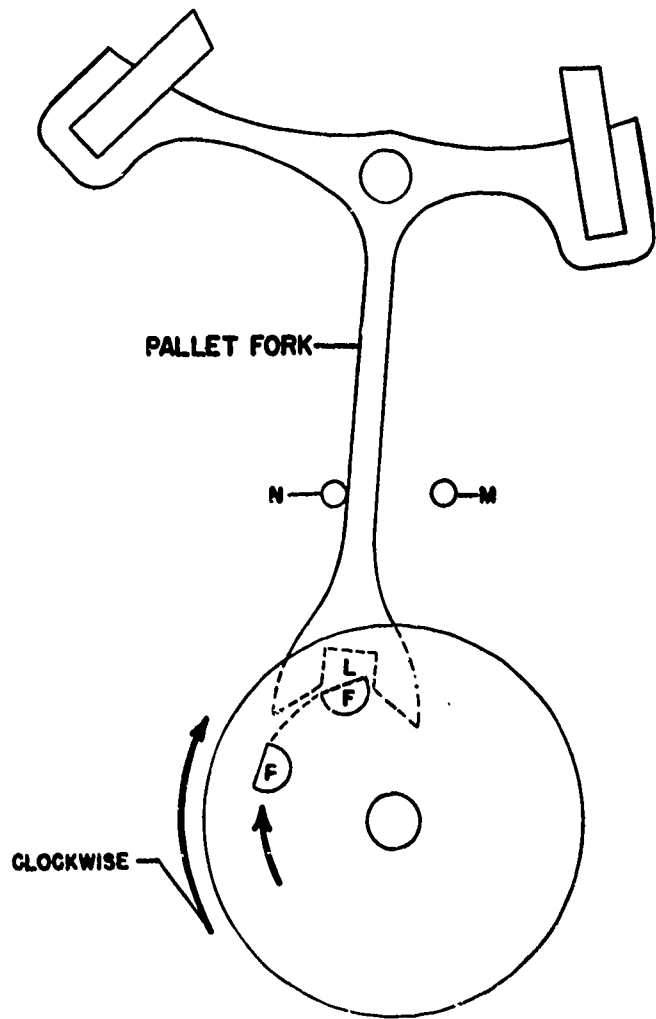

FIG. 5B

5-C

PREPARATION FOR REMOVING THE PALLET BRIDGE

IMPORTANT: LET DOWN THE MAINSPRING POWER

Before proceeding, the mainspring power must be released. To accomplish this, proceed as follows:

1. Grip the crown between the forefinger and thumb as if to wind the watch.
2. Turn the crown slowly and observe the action of the "click" on the ratchet wheel teeth.
3. When the click on the ratchet wheel is forced out from between the teeth of the ratchet wheel, take a small screwdriver and push the click completely out of engagement with the wheel.
4. While holding the click in this position, turn the crown slowly to let down the power of the mainspring. Do not let the mainspring power spin down quickly but release it slowly to prevent damage from occurring.

REMOVING THE PALLET BRIDGE

To remove the pallet bridge, remove the bridge screw which holds this bridge in place. Now slide a finely sharpened screwdriver between the base of the bridge and the plate at location "C" and turn the screwdriver. This will raise the bridge, loosening the steady pins in the bridge from the holes in the plate. After the bridge is loosened from the plate, lift the bridge out of place with a pair of tweezers.

HAZARDS IN REMOVING THE PALLET BRIDGE

When sliding the screwdriver under the bridge to raise the bridge, care should be taken to keep the bridge level, because any twisting of the bridge may damage the pivot on the pallet fork.

REPLACING THE PALLET BRIDGE

Place the bridge in position on the plate as shown in Figure 6. Check to see that the steady pins "A" on the bridge are entering their proper holes in the pillar plate. Now press the bridge down lightly with a piece of pegwood until the bridge lightly touches the pallet fork's top pivot. Now, with a pair of tweezers, move the fork slightly until the top pivot enters the jewel hole in the bridge. The bridge can now be pressed down to the proper place, and the bridge screw can be replaced. After the bridge is replaced, check to see that the pallet fork pivots freely.

FUNCTION OF THE PALLET BRIDGE

The function of this bridge is to hold the pallet fork in position and to provide a bearing for the upper pivot of the pallet fork.

REFERENCE POINTS

- A - Steady pins
- C - Position to insert screwdriver to loosen bridge
- D - Pallet fork upper jewel bearing

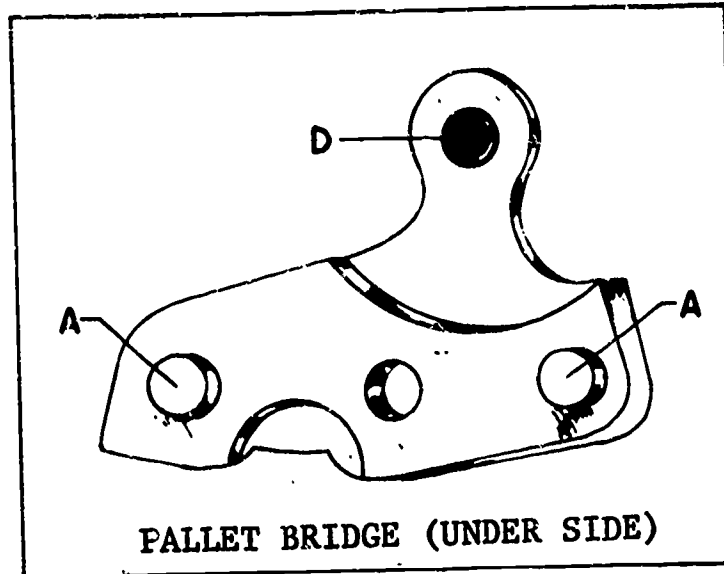

PALLET BRIDGE
PART NUMBER 6

FIG. 6

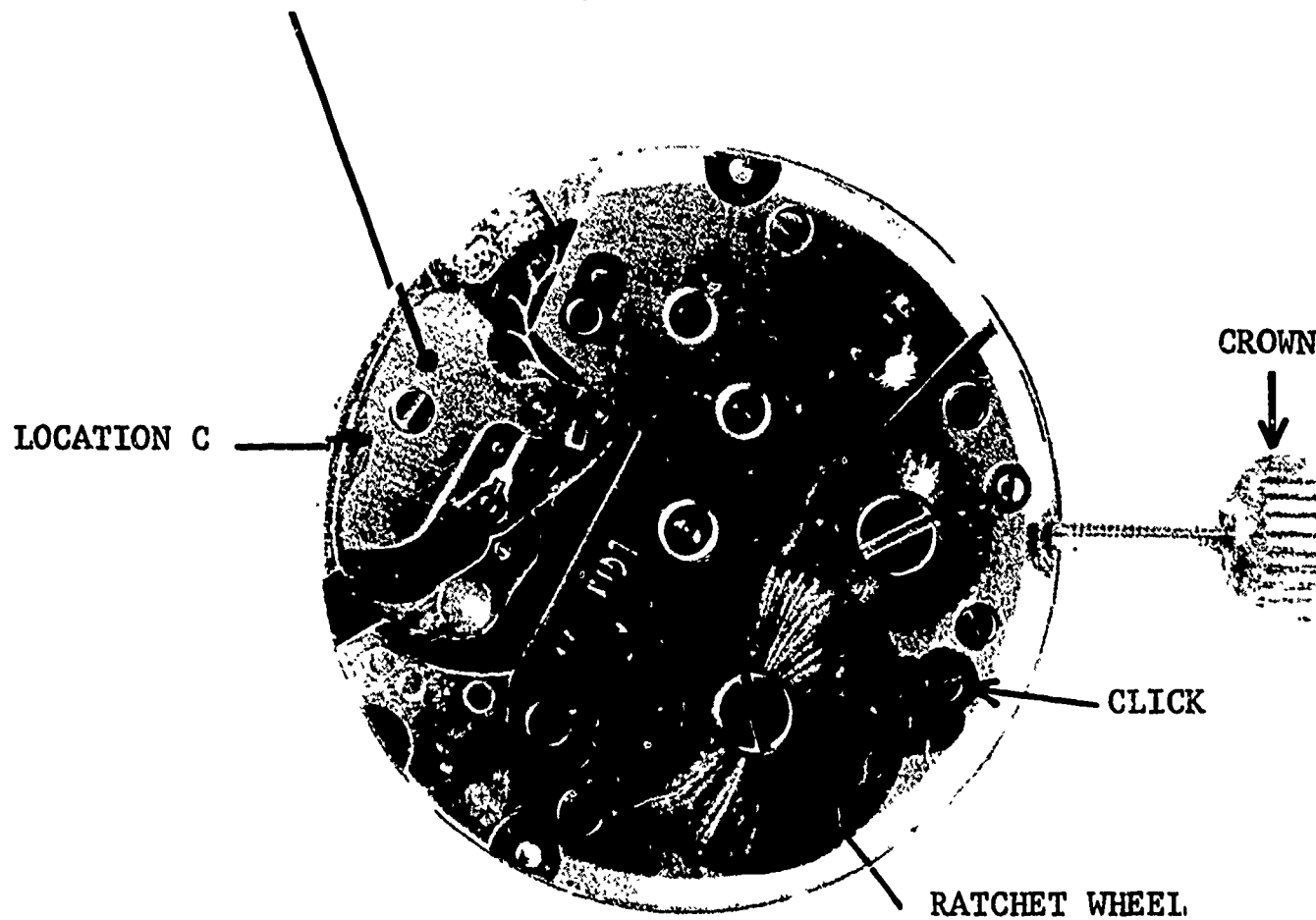

6-A

REMOVING THE PALLET FORK

Grasp the pallet fork at location "A" with a pair of tweezers, and lift straight up, removing the lower pivot on the pallet fork from its pivot hole in the pillar plate.

HAZARDS IN REMOVING THE PALLET FORK

When removing the pallet fork, lift straight up, because any tilting of the pallet fork may cause the lower pivot to bind in the jewel hole in the plate and result in the bending or breaking of the pivot.

Notice: The pallet stones "E" in the pallet fork should never be handled with tweezers. The pallet stones are very easily chipped or cracked, and even a small chip in a pallet stone may make it unfit for further use.

REPLACING THE PALLET FORK

Grip the pallet fork with tweezers at location "A". Place the bottom pivot "H" of the pallet arbor in its jewel hole in the plate. Part "B" of the fork should be placed between the two banking pins "M" and "N", as shown in Figure 7.

FUNCTION OF THE PALLET FORK

The pallet fork transfers the power from the escape wheel to the balance unit. The pallet fork changes the rotary motion of the train into the oscillating motion of the balance wheel.

REMARKS

The pallet stones are made of synthetic ruby or sapphire, the former being the most popular today. The pallet stones in this watch are synthetic ruby. The pallet fork itself is usually made of steel or silver-plated brass.

REFERENCE POINTS

- A - Location to grasp pallet fork with tweezers
- B - Part of pallet fork that must be set between banking pins
- F - Pallet stones
- F - Pallet arbor
- G - Upper pivot
- H - Lower pivot
- J - Fork slot

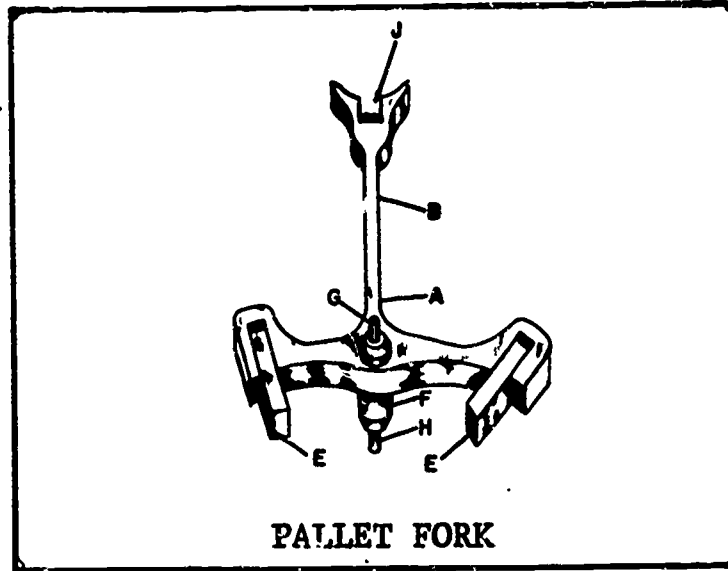

PALLET FORK

FIG. 7

PALLET FORK
PART NUMBER 7

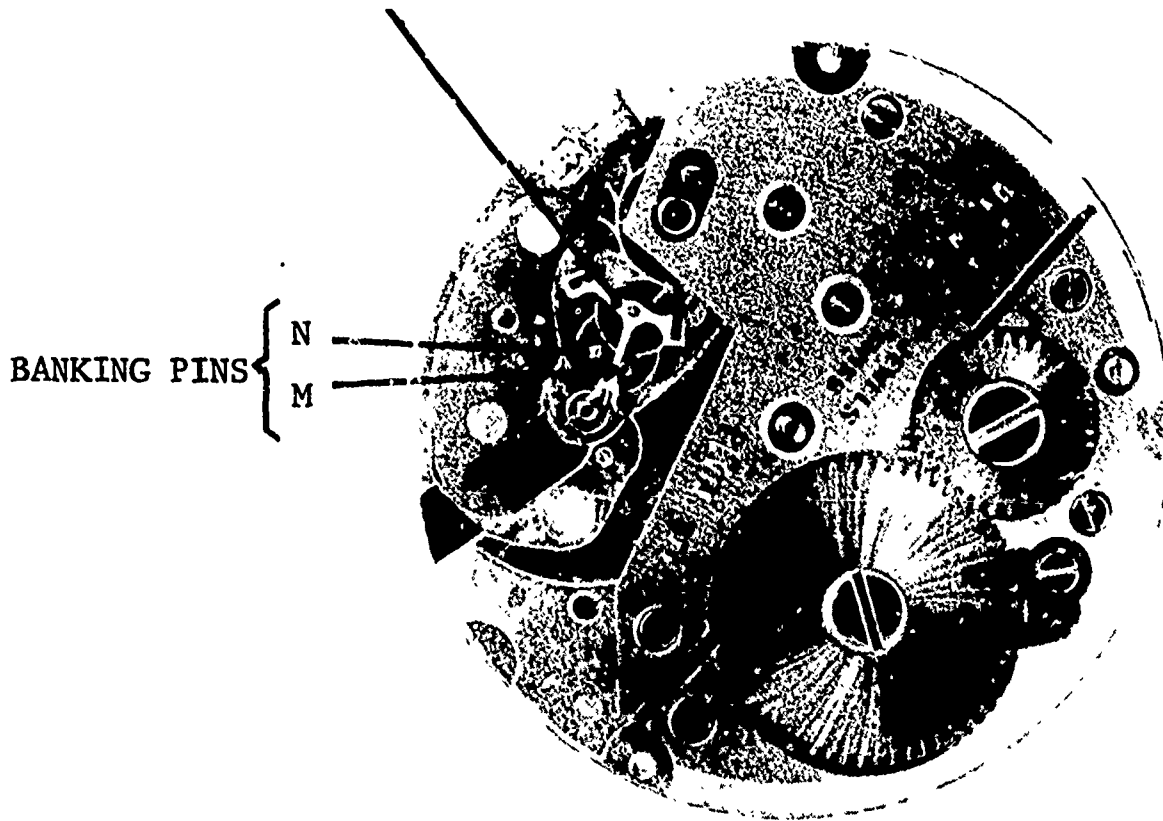

7-A

REMOVING THE RATCHET WHEEL

Remove the right-threaded ratchet screw that holds the ratchet wheel in place. After this is done, simply lift the ratchet wheel out of place.

REPLACING THE RATCHET WHEEL

There are two things that must be kept in mind when replacing the ratchet wheel: (1) fit the ratchet wheel into position over the protruding square of the barrel arbor so that (2) it also meshes properly with the click.

Place the ratchet wheel in position on the barrel bridge with the square hole in the wheel fitted over the protruding square of the mainspring barrel arbor. Replace the ratchet screw to hold this wheel in place.

FUNCTION OF THE RATCHET WHEEL

The function of the ratchet wheel is to turn the barrel arbor to wind the mainspring.

REMARKS

The ratchet screw or the crown wheel screw (or both) may have a left-thread. For this reason care must be taken in removing such screws to make sure that they are turned in the proper direction. In this particular watch the ratchet screw has a standard right-thread, but the crown wheel screw has a left-thread.

It might be worth noting that some manufacturers machine two additional slots in the screw head, along side of the regular screw slot, to indicate a left-threaded screw.

REFERENCE POINTS

- A - Square hole that fits on end of barrel arbor
- B - Ratchet wheel teeth

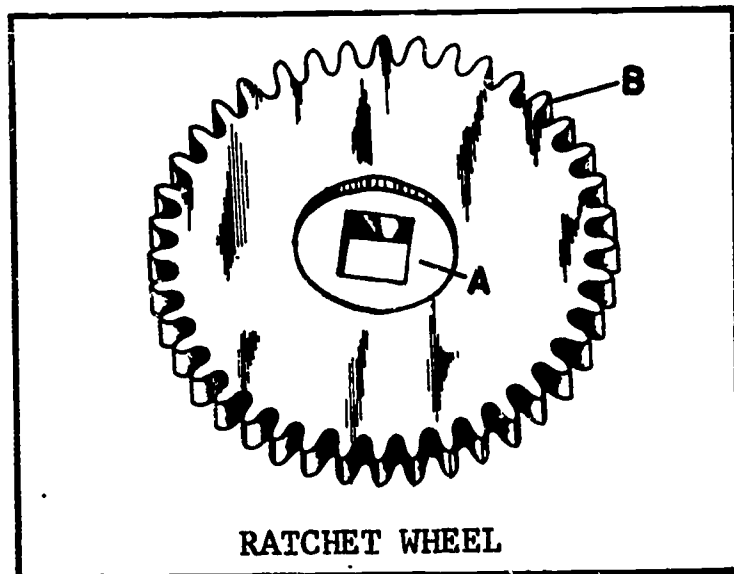
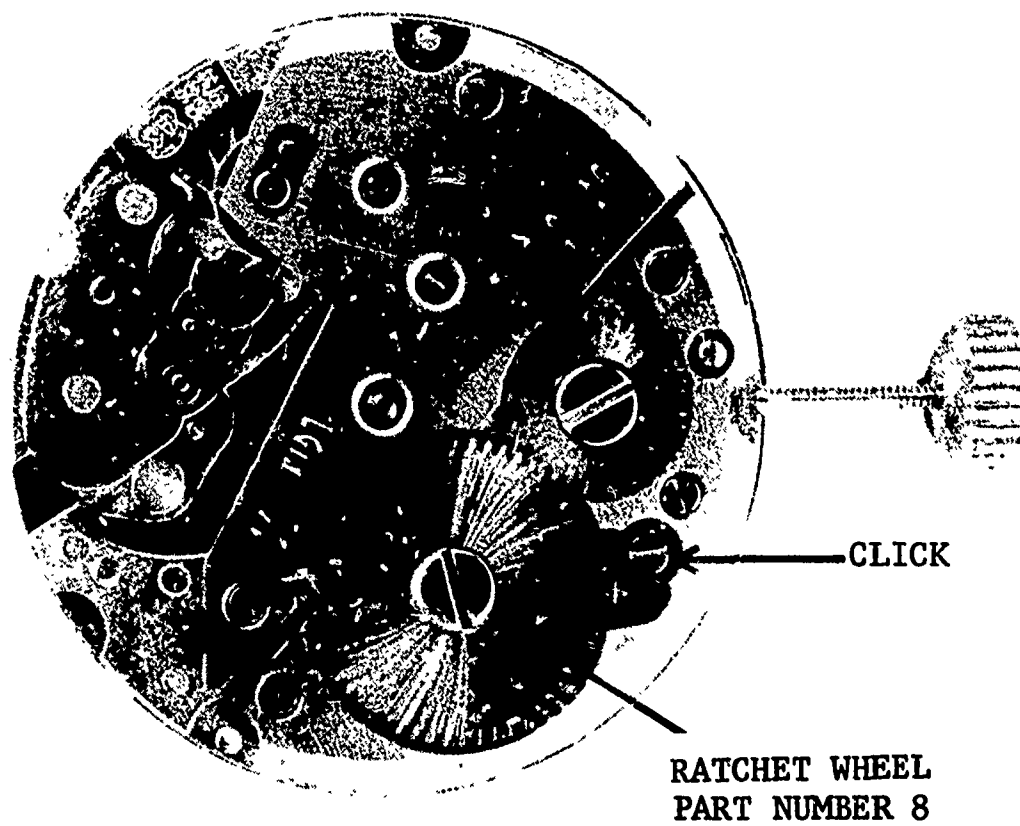

FIG. 8



8-A

REMOVING THE CROWN WHEEL

The crown wheel screw in this particular watch is left-threaded and is removed by turning it in the opposite direction (clockwise) from that of the other screws in the watch. To remove the crown wheel after the screw is removed, simply lift it out of place with tweezers. (To serve as a bearing surface for the crown wheel, a small washer is fitted over an internally threaded tube on the plate. To prevent loss of this washer, also lift it out of place with tweezers.)

HAZARDS IN REMOVING THE CROWN WHEEL WASHER

Care must be taken to hold the crown wheel washer lightly with the tweezers when lifting it out of place, in order to prevent it from shooting out of the tweezers and becoming lost.

REPLACING THE CROWN WHEEL

Before replacing the crown wheel, place the crown wheel washer over the internally threaded tube in the plate. After this is done, put the crown wheel over the washer and replace the left-threaded screw to hold this wheel in place.

FUNCTION OF THE CROWN WHEEL

The crown wheel serves as an intermediate wheel between the winding pinion and the ratchet wheel. When the watch is being wound, it transfers the power from the winding pinion to the ratchet wheel which is fastened to the mainspring arbor.

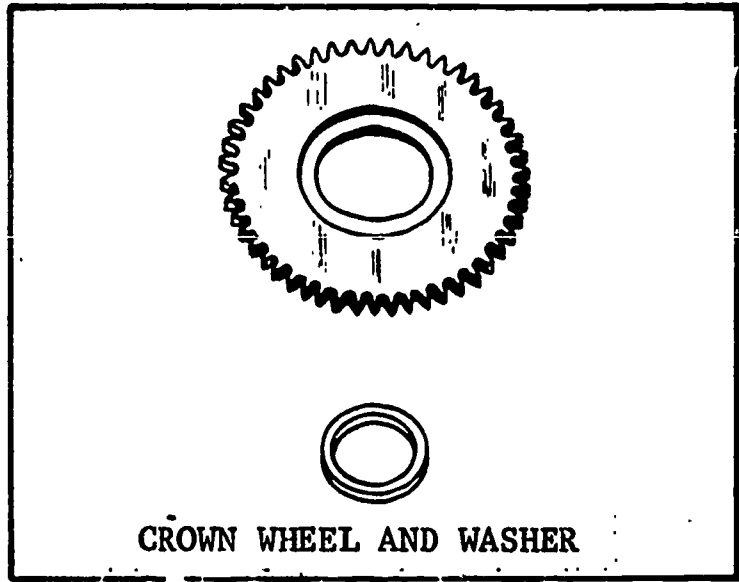
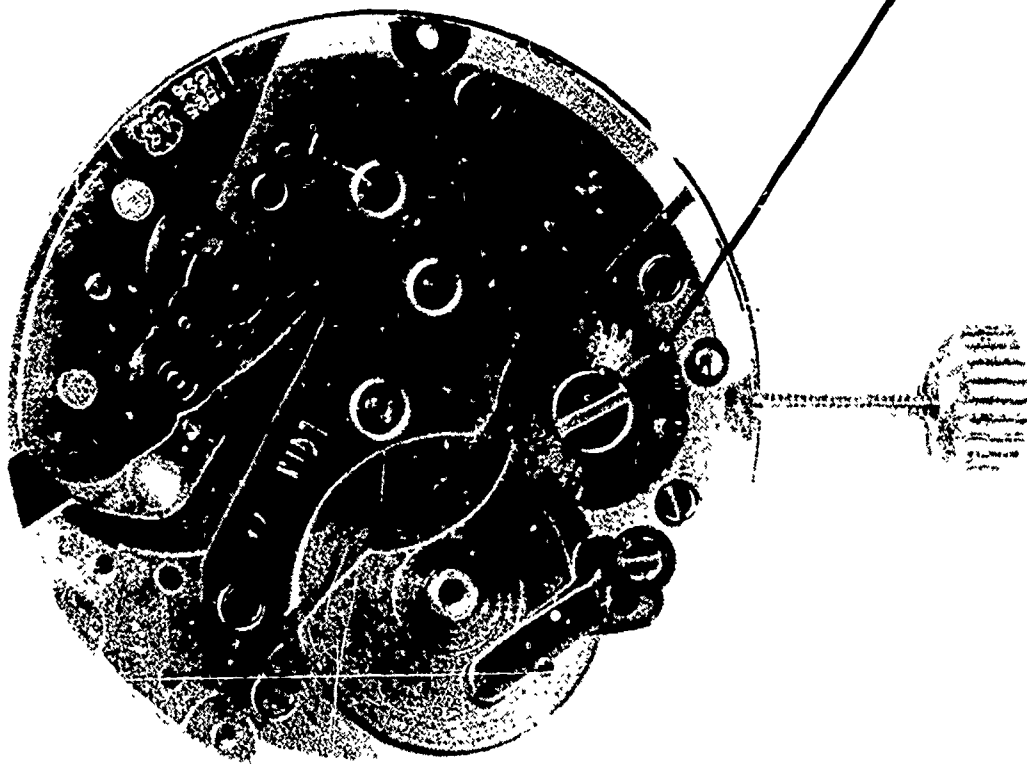

FIG. 9

CROWN WHEEL
PART NUMBER 9



9-A

REMOVING THE BARREL BRIDGE

Remove the three plate screws that hold this bridge in place. Now with a finely sharpened screwdriver, loosen the bridge at the two notches provided under the bridge for this purpose. After doing this, lift the bridge out of place with the tweezers.

REPLACING THE BARREL BRIDGE

Place the bridge in its proper position over the mainspring barrel with the steady pins on the bridge over their respective holes in the plate. Make sure that the end of the mainspring barrel arbor has entered the proper bearing hole in the bridge. Now, push down lightly on the bridge to seat it. When the barrel bridge is in the proper position, replace the three plate screws that hold this bridge in place.

FUNCTION OF THE BARREL BRIDGE

The barrel bridge (1) provides an upper bearing for the barrel arbor, (2) provides a support for the crown wheel and its bearing washer, (3) provides a recess for the click spring and a bearing for the ratchet click, and (4) provides a hole and recess for the setting lever screw.

REFERENCE POINTS

- A - Bearing hole for barrel arbor
- B - Hole provided for detent screw

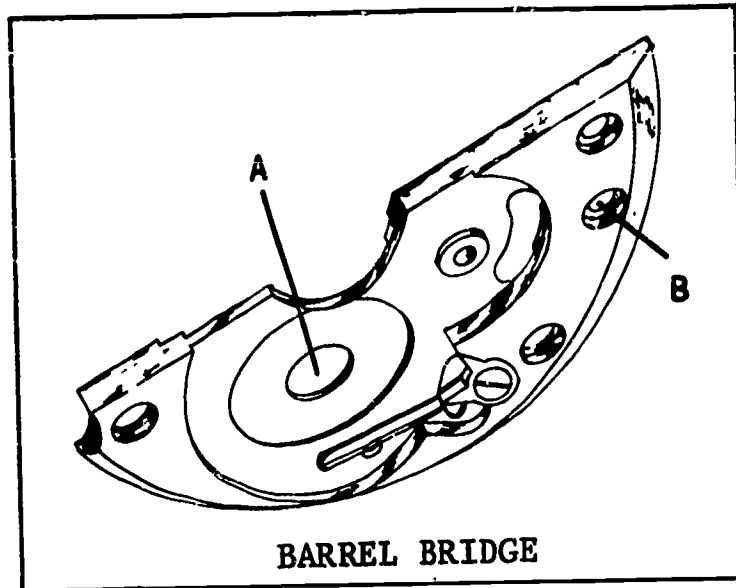
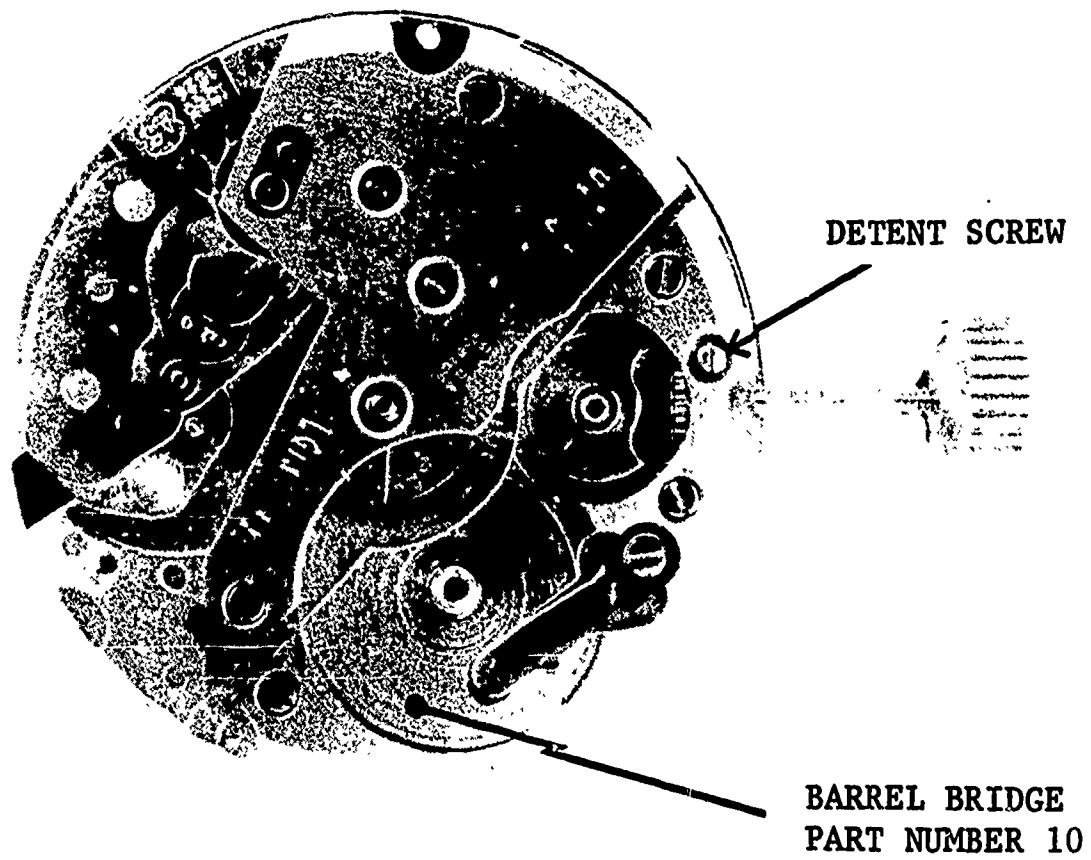

FIG. 10



10-A

REMOVING THE MAINSPRING BARREL

To remove the mainspring barrel, simply lift the barrel out of place.

REPLACING THE MAINSPRING BARREL

Place the barrel in its proper position as shown in Figure 11 with the lower pivot on the barrel arbor in the proper bearing hole in the plate.

FUNCTION OF THE MAINSPRING BARREL

The mainspring barrel holds the mainspring in such a manner that when the mainspring is wound up, the mainspring forces the barrel to turn and thus drives the watch train. In other words, it supplies the power to run the watch.

REMARKS

The train wheels and the pinions in this watch have the following number of teeth and leaves:

| | Number of wheel teeth | Number of pinion leaves |
|-------------------------------|--------------------------|----------------------------|
| Barrell | 70 | |
| Center wheel and pinion . . . | 64 | 10 |
| Third wheel and pinion . . . | 60 | 8 |
| Fourth wheel and pinion . . . | 70 | 8 |
| Escape wheel and pinion . . . | 15 | 7 |

The most popular ratio for train gearing is as follows:

| | <u>Ratio</u> |
|---------------------------------|------------------|
| Barrel to center pinion, either | 8 to 1 or 7 to 1 |
| Center wheel to third pinion | 8 to 1 |
| Third wheel to fourth pinion | 7 1/2 to 1 |
| Fourth wheel to escape pinion | 10 to 1 |

REFERENCE POINT

A - Barrel arbor

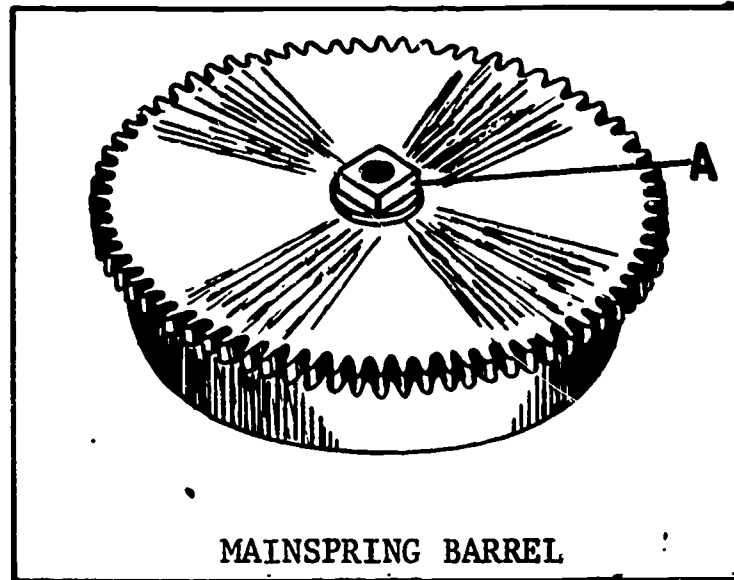
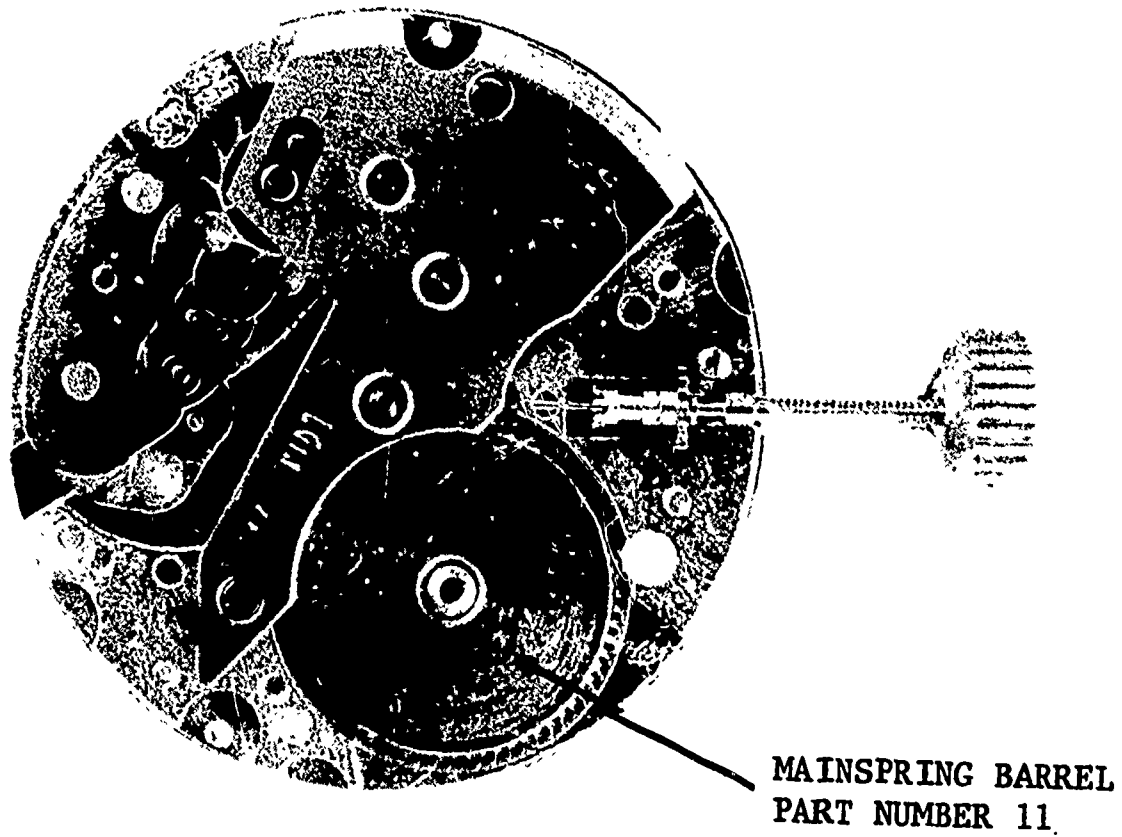

FIG. II



11-A

REMOVING THE TRAIN BRIDGE

The train bridge is held in place by two identical plate screws. After removing these two screws, slide a finely sharpened screwdriver under one of the notches at the base of the bridge, and turn the screwdriver. This will raise one end of the bridge. The other end of the bridge can now be raised in the same manner. Keep the bridge as level as possible when raising it. When the positioning (aligning) pins on the bridge are free in the pillar plate, the bridge may be lifted straight up out of place with a pair of tweezers.

REPLACING THE TRAIN BRIDGE

Place the bridge in its proper position on the pillar plate, as shown in Figure 12. Now proceed as follows:

1. Place a finger sock over the forefinger of the left hand.
2. Hold a downward pressure on the bridge with the forefinger. (The forefinger should be placed on the bridge in the position between the center wheel and third wheel pivot holes.)
3. Move the center wheel with the tweezers so that the upper pivot of the center wheel enters the jewel hole in the bridge.
4. Follow the same procedure with the other train wheels. While maintaining a light downward pressure on the bridge, straighten up the wheels with tweezers so that the top pivots of the wheels will enter their respective jewel holes. The wheel that feels tight is the one that should be straightened first. When that pivot has entered its proper jewel hole, proceed to feel for the next wheel that is tight. Follow this procedure until all the wheels are in place and the bridge is seated properly.
5. With a piece of pegwood or tweezers, press against a wheel spoke to turn the train wheels to see if they rotate freely. The train wheels spinning freely indicate that all the pivots are in their proper pivot holes and the wheels are in their proper places.
6. Replace the plate screws that hold this bridge in place.
7. After the train bridge and screws are replaced, again check the train wheels to see that they rotate freely.

FUNCTION OF THE TRAIN BRIDGE

The train bridge holds the train wheels in position by providing upper bearings for the pivots of the train wheels.

REFERENCE POINTS

- A - Upper center wheel bearing
- B - Upper third wheel bearing
- C - Upper fourth wheel bearing
- D - Upper escape wheel bearing

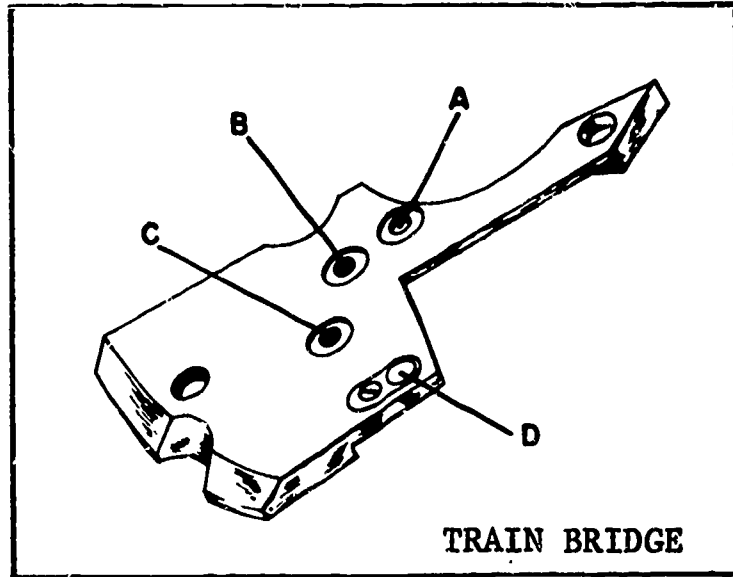
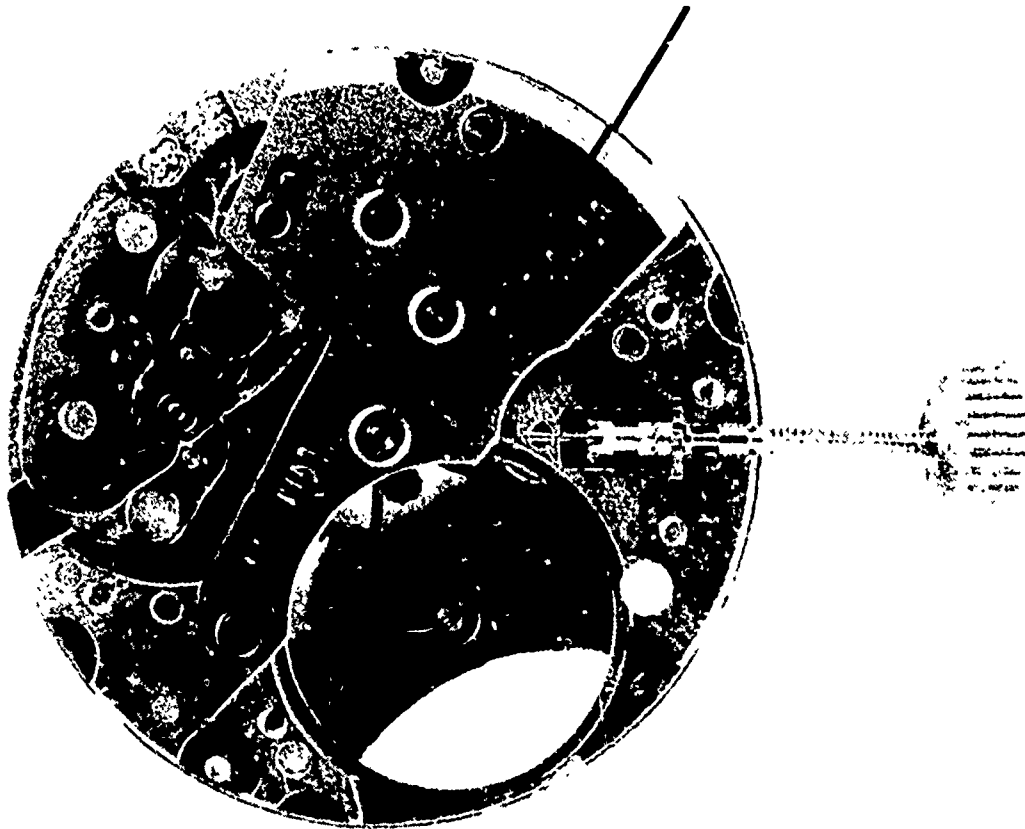

FIG. 12

TRAIN BRIDGE
PART NUMBER 12



12-A

REMOVING THE CENTER WHEEL

To remove the center wheel, grip a spoke on the wheel with the tweezers and lift the wheel straight up until the long post "A" is out of the pivot hole in the plate. Do not tilt the wheel when lifting it out of place, because the long post "A" may bind in the hole.

REPLACING THE CENTER WHEEL

To replace the center wheel, grip a spoke on the wheel with the tweezers, and place the long post "A" down in the center hole in the pillar plate. The pinion leaves "C" on the center wheel pinion should mesh with the teeth on the mainspring barrel. Also, the teeth "D" of the center wheel should mesh with the pinion leaves on the third wheel pinion.

FUNCTION OF THE CENTER WHEEL

The center wheel (1) transfers the power from the barrel to the wheels of the train and (2) also transfers the power from the train side of the watch to the cannon pinion of the dial train on the dial side of the watch.

REMARKS

When referring to train wheel pinions, the teeth on the pinion are referred to as "leaves". On wheels, they are referred to as "teeth" in order to provide a clear understanding of the difference between wheels and pinions.

Since the wheels drive the pinions, a wheel will be referred to as the driving member, and a pinion will be referred to as the driven member.

REFERENCE POINTS

- A - Long center wheel post
- C - Center wheel pinion leaves
- D - Center wheel teeth

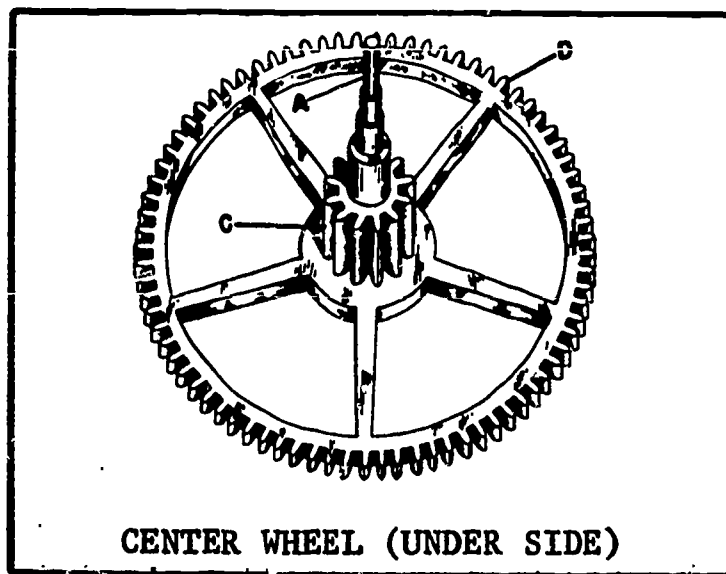
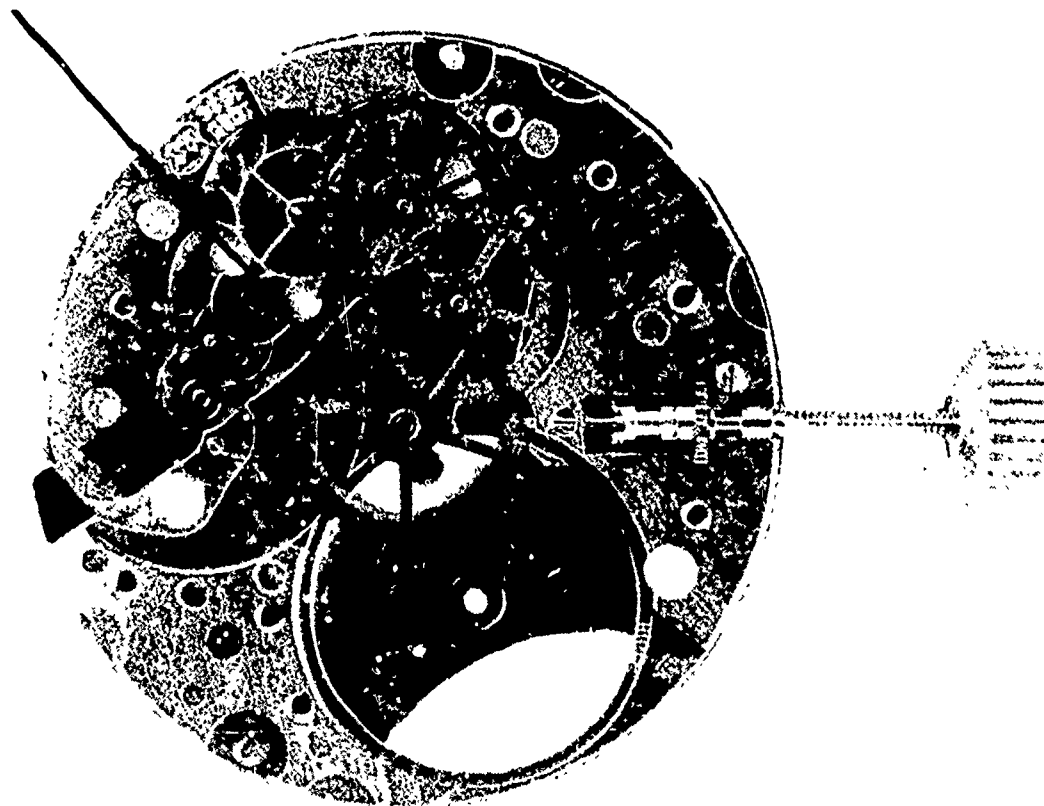

FIG. 13

CENTER WHEEL
PART NUMBER 13



13-A

REMOVING THE THIRD WHEEL

To remove the third wheel, grip the leaves "C" of the third wheel pinion with tweezers, and lift the wheel straight up out of place.

HAZARDS IN REMOVING THE THIRD WHEEL

When removing this wheel, lift the wheel straight up so that the lower pivot cannot bind in the pivot hole.

REPLACING THE THIRD WHEEL

Grip the leaves "C" of the third wheel pinion with the tweezers. Now place the third wheel in the position shown in Figure 14 with the pivot "A" down in the proper jewel hole in the pillar plate. The teeth of the third wheel should mesh with the leaves of the fourth wheel pinion.

FUNCTION OF THE THIRD WHEEL

The third wheel transfers the power from the center wheel to the fourth wheel.

REMARKS

In watchmaking, "the train" refers to the series of wheels through which the power of the mainspring is transferred to the escapement mechanism. The first wheel in the train is the barrel. The second wheel is referred to as the center wheel, because it is ordinarily located in the center of the watch. The third wheel is next to the center wheel. The fourth wheel is next in line, and the fifth (or escape) wheel completes the entire train.

REFERENCE POINTS

- A - Lower pivot
- B - Upper pivot
- C - Leaves
- D - Teeth

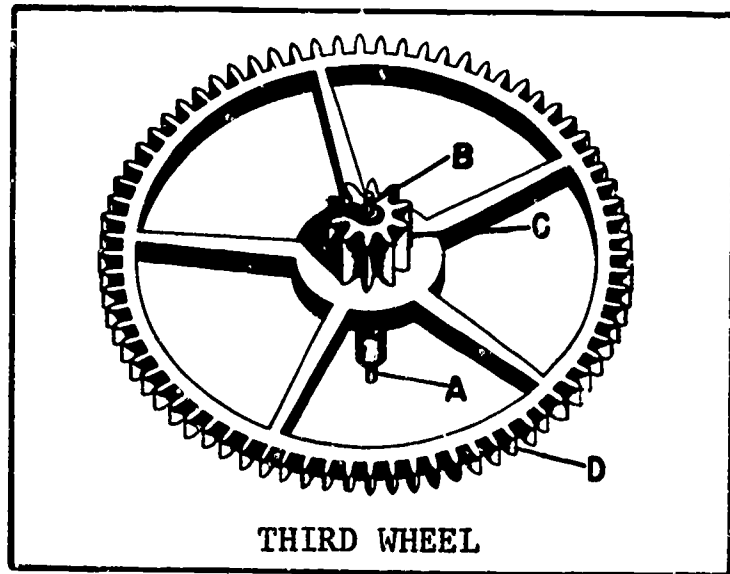
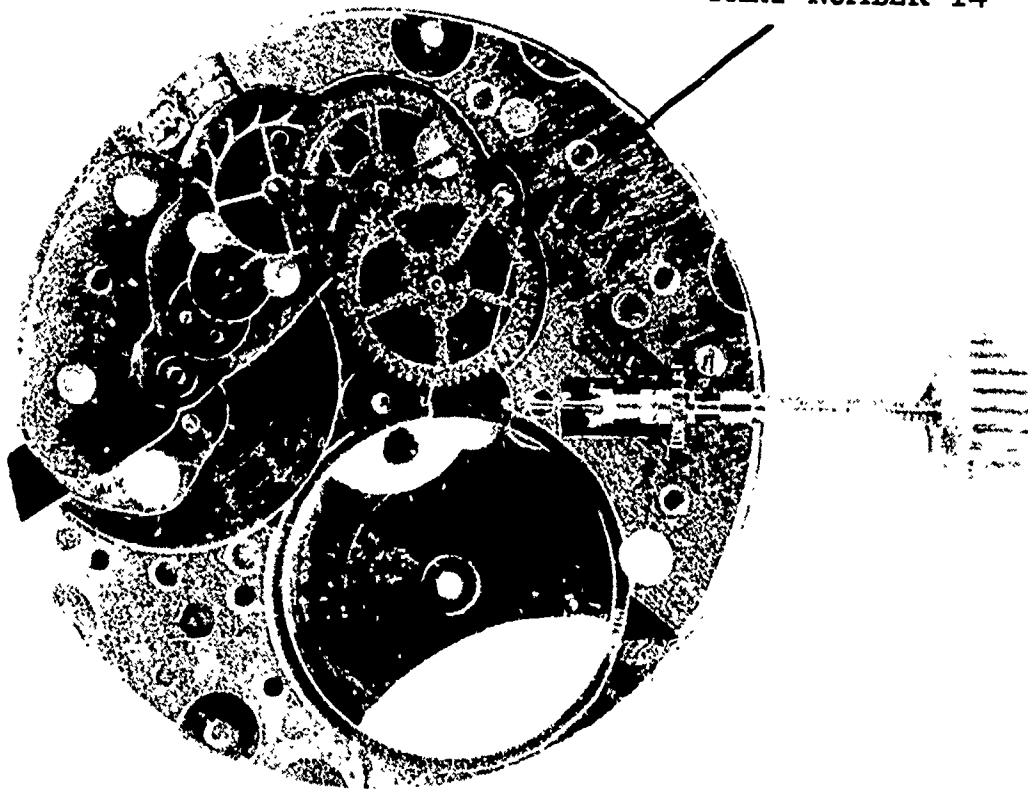

FIG. 14

THIRD WHEEL
PART NUMBER 14



14-A

REMOVING THE FOURTH WHEEL

To remove the fourth wheel, grip the leaves "C" of the fourth wheel pinion with a pair of tweezers, and lift straight up until the long pivot "A" is free of the jewel hole in the pillar plate. Any tilting of the fourth wheel when removing it may cause the long pivot "A" to be bent or broken, or a chip to occur in the wall of the jewel hole.

REPLACING THE FOURTH WHEEL

Grip the leaves "C" of the fourth wheel pinion with the tweezers. Now place the fourth wheel in the position shown in Figure 15 with the long pivot "A" down in the proper jewel hole in the pillar plate. The teeth of the fourth wheel should mesh with the leaves on the escape wheel pinion.

HAZARDS IN REPLACING THE FOURTH WHEEL

When replacing the fourth wheel, do not tilt this wheel, because this may chip the jewel hole in the plate or may bend the pivot of the fourth wheel.

FUNCTION OF THE FOURTH WHEEL

The fourth wheel transfers the power from the third wheel to the escape wheel. A second hand, when attached to the long pivot "A", indicates the passage of seconds on the dial.

REMARKS

When removing or replacing the train wheels, avoid lifting the wheels by the pivots. The pivots on these wheels must be highly polished to function properly. To lift the wheels by the pivots may scratch or burr these pivots, so that they will not turn freely in the bearings.

REFERENCE POINTS

- A - Lower long pivot
- B - Teeth
- C - Leaves
- D - Upper pivot

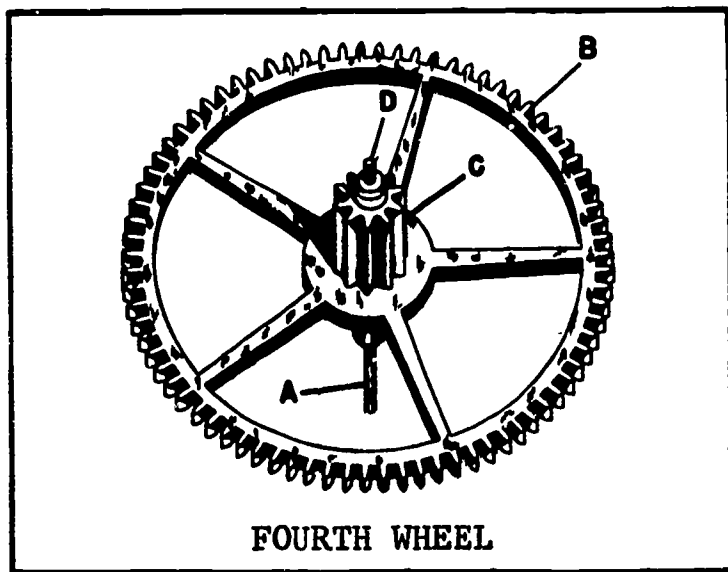
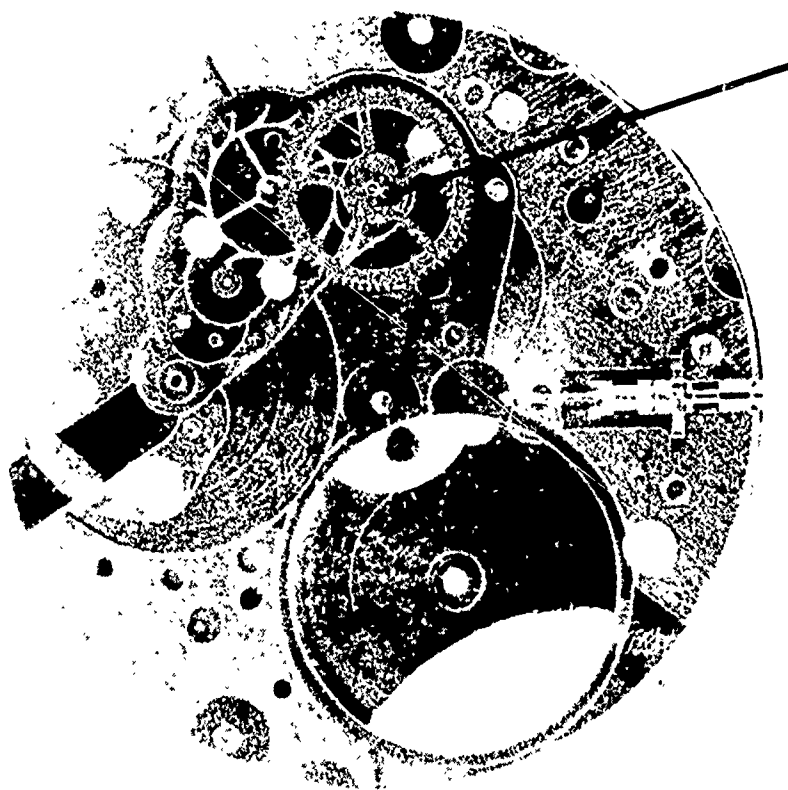

FIG. 15



FOURTH WHEEL
PART NUMBER 15

15-A

REMOVING THE ESCAPE WHEEL

The escape wheel is removed by lifting it straight up, freeing the pivot "A" from the jewel hole in the pillar plate. The wheel and pinion should be lifted by gripping the pinion "B" with the tweezers.

HAZARDS IN REMOVING THE ESCAPE WHEEL

The escape wheel should be lifted straight up when removing it. Any tilting of the wheel may bend the pivot or chip the jewel hole in the pillar plate. Handle the escape wheel very carefully, because the escape wheel teeth "D" can be easily damaged.

REPLACING THE ESCAPE WHEEL

Grip the pinion "B" of the escape wheel with the tweezers. Now place the escape wheel in the position shown in Figure 16 with the pivot "A" down in the jewel hole in the pillar plate. The same precautions should be taken to prevent bending or burring of the pivot, or chipping of the jewel hole, as were taken previously when removing the escape wheel from the watch.

FUNCTION OF THE ESCAPE WHEEL

The escape wheel gives an impulse to the pallet fork. This impulse is transferred to the balance by the roller jewel.

REMARKS

The escape wheel is the first of the train wheels to be replaced in the watch. This wheel is purposely replaced first, because the next wheel to be replaced (the fourth wheel) covers part of the escape wheel. When assembling a watch train, always replace the wheels in this order, because as each wheel is replaced, it covers part of the preceding wheel. Never replace a train wheel underneath another train wheel when it can be avoided.

REFERENCE POINTS

- A - Lower pivot
- B - Pinion
- C - Leaves
- D - Club teeth



FIG. 16

ESCAPE WHEEL
PART NUMBER 16

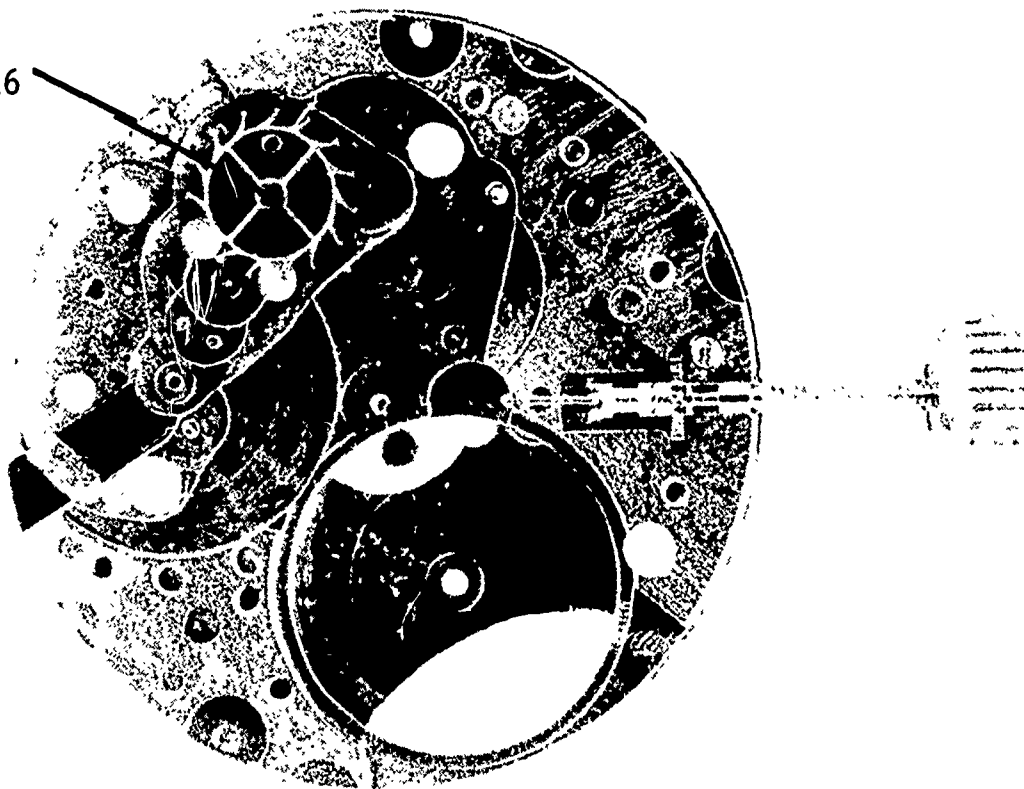

16-A

APPENDIX B

THE DETACHED LEVER ESCAPEMENT
FUNCTION AND ADJUSTMENT

THE DETACHED LEVER ESCAPEMENT
FUNCTION AND ADJUSTMENT

BY

WILLIAM O. SMITH, JR.

GRAY LAWRENCE

HUGH G. WALES, PH.D.

WATCH TECHNICIAN
AND
MICRO-PRECISION TECHNOLOGY

UNIVERSITY OF ILLINOIS
URBANA, ILLINOIS

Proper Use of this Escapement Book

It is most desirable to have the student use an escapement model to practice on while studying the material that is presented in section I of this escapement book. If an escapement model is not available, then it is preferred that the student simply study the text and illustrations and have before him a watch movement to which he can refer from time to time.

The primary objective of the first section of this book is to present the function and adjustment of the escapement without involving the student in making the delicate and sometimes intricate adjustments within the watch itself. When section I is completed by the student, it is recommended that a period of about two weeks be spent on other subjects before returning the student to escapement work within the watch itself, which is fully covered in section II of this book. However, before proceeding with section II, it is recommended that the material previously covered in section I be reviewed. When section I and section II of this book have been completed, it is again recommended that the student spend about two weeks on subjects other than the lever escapement. Before starting section III, however, which deals with a checking system used to determine the accuracy of the adjustments that were previously dealt with in section II, a complete review of sections I and II is highly recommended. By using this escapement book in accordance with the suggestions outlined above, better results will be obtained in the classroom.

Total time to cover each section of this book is as follows:

Section I - 20 hours

Section II - 20 hours

Section III - 10 hours

DETACHED LEVER ESCAPEMENT

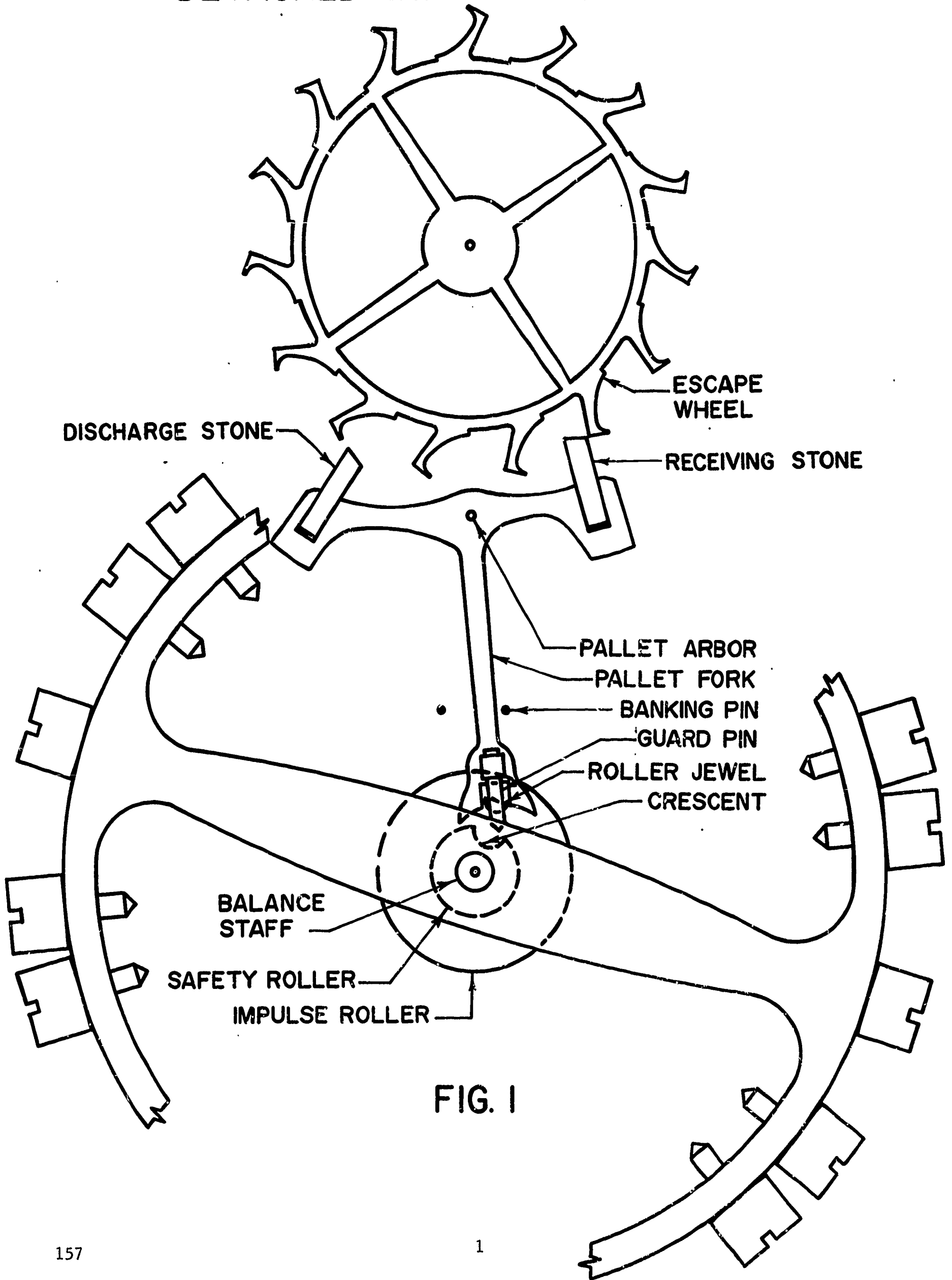

DETACHED LEVER ESCAPEMENT

Figure 1 shows the names of the various parts that make up the lever escapement. It is most important that the student become familiar with these parts illustrated, or it will prove difficult and confusing to try to understand the technical lessons that follow.

There are quite a number of different escapements employed in watches and clocks. The detached lever escapement is by far the most popular escapement used in timekeeping instruments today. For this reason, we will study the detached lever escapement first and then later study the various other types of escapements. The lever escapement consists of the following units: (see figure 1)

1. Impulse and safety roller (attached to the balance staff)
2. Pallet fork
3. Escape wheel

The purpose of the escapement is to change the circular motion of the train into the oscillatory motion of the balance. In the detached lever escapement, the balance unit is the timekeeping element of the watch. The balance unit, as it oscillates, unlocks the escapement at regular intervals, thus letting down the power of the train at the proper rate to turn the hands on the dial to indicate the correct passage of time. If the balance unit oscillates too fast, then the watch will run fast. If the balance unit oscillates too slowly, then the watch will run slowly. In most watches today, the balance unit must oscillate at a rate of 18000 times per hour for the watch to keep correct time.

FUNCTION OF THE ESCAPEMENT

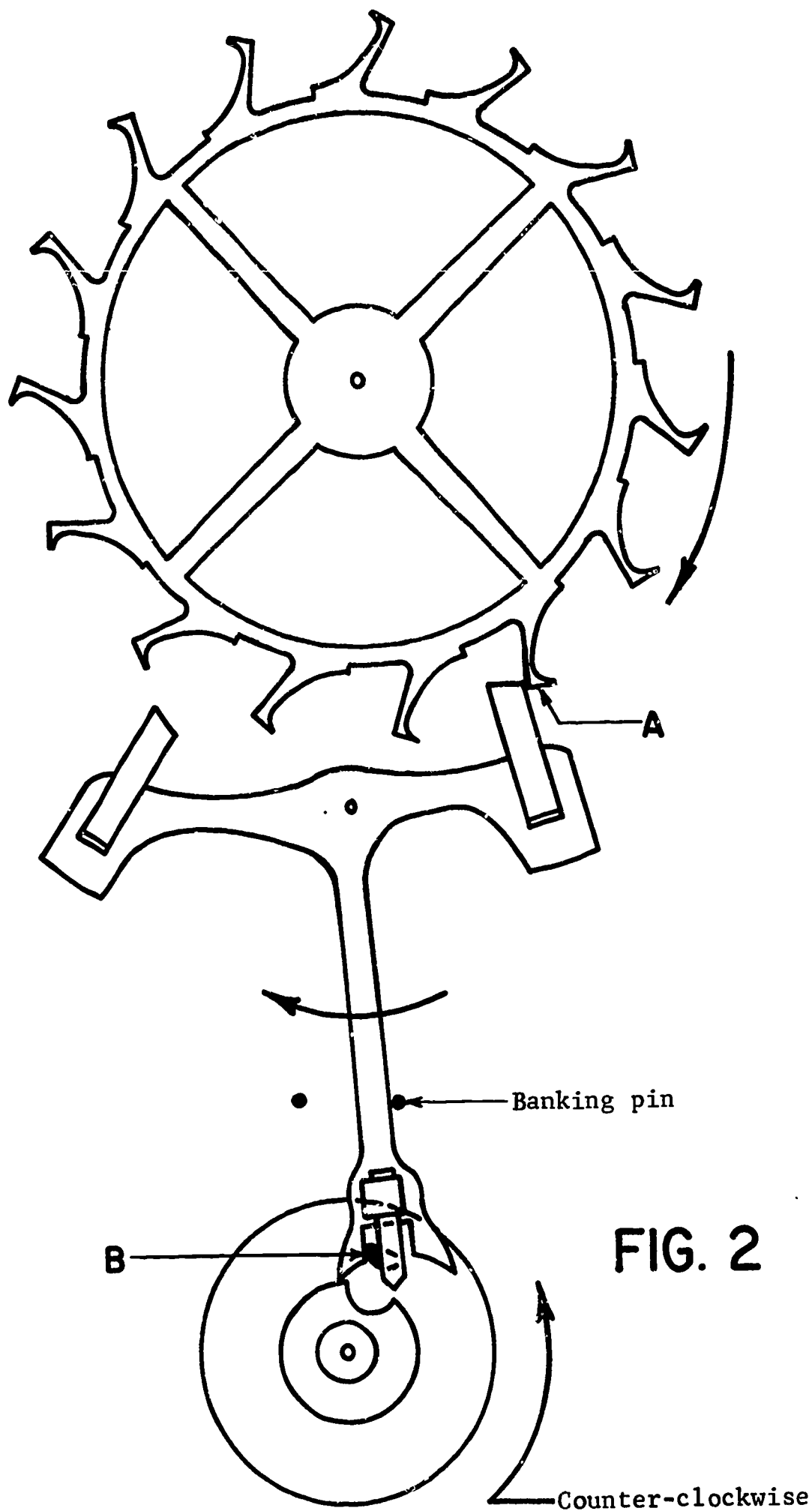

Function of the Escapement - Figure 2 through Figure 11

Before proceeding to adjust the escapement, it would be worthwhile to review the function of the lever escapement. In figure 2, we show the escape tooth "A" locked on the receiving pallet stone. The roller table is turning counter-clockwise by virtue of the hairspring (not shown) and the roller jewel "B" is at a position of contact in the slot of the pallet fork. (Note: the pallet fork has not yet been moved from the banking pin). Now as the roller table continues to turn, the roller jewel will move the fork in the direction of the arrow. This unlocks the tooth "A" of the escape wheel (see figure 3).

FUNCTION OF THE ESCAPEMENT

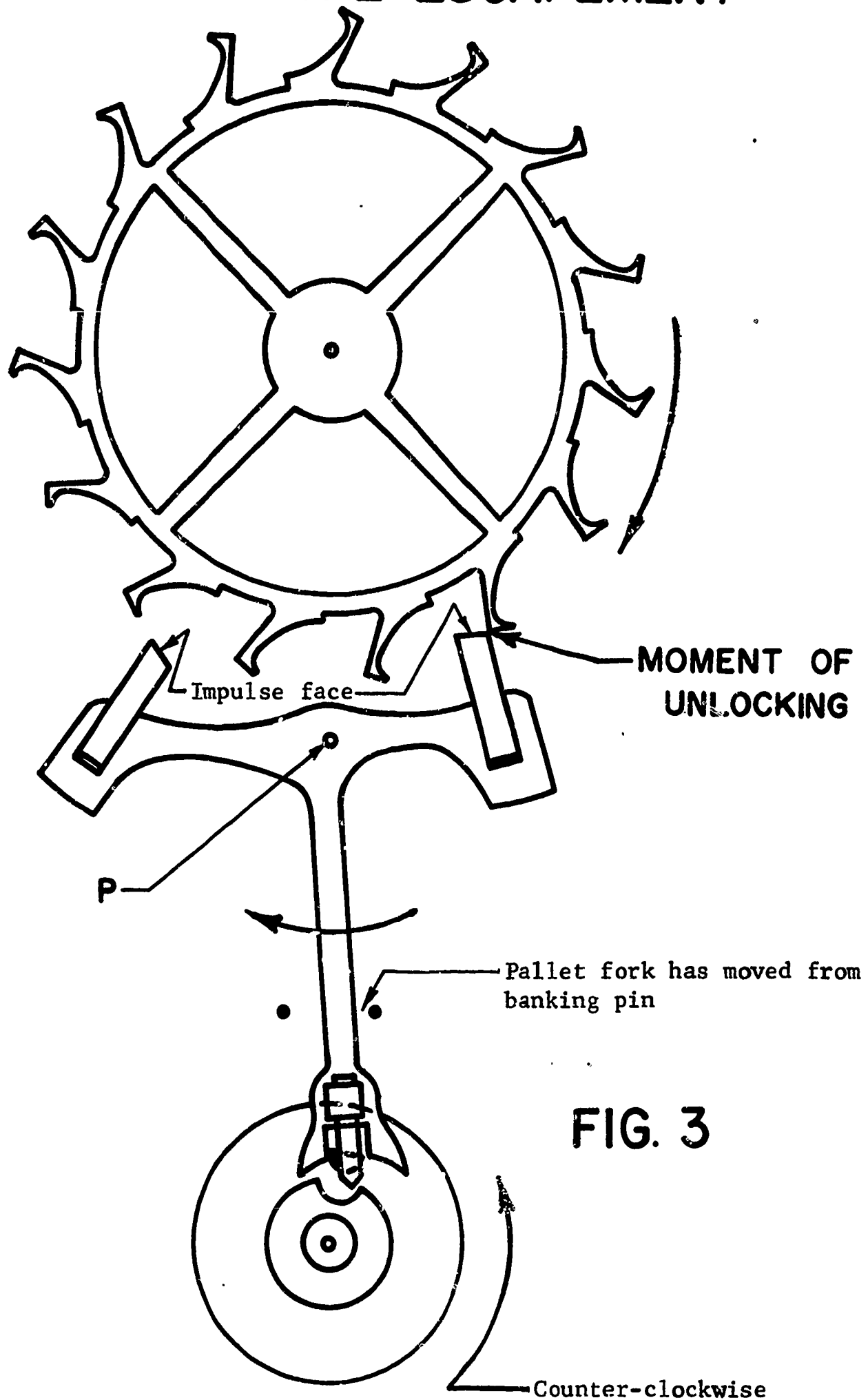

Figure 3 shows the pallet fork when it has moved away from its banking pin to a point where the escapement is unlocking. Remember: it is the movement of the roller table and roller jewel counter-clockwise that causes the escapement to be unlocked on the receiving side.

After the escape tooth is unlocked, it will travel up the impulse face of the pallet stone, thus causing the fork to pivot on its arbor "P" in the direction of the arrow, giving a kick or impulse to the roller jewel in a counter-clockwise direction (see figure 4).

FUNCTION OF THE ESCAPEMENT

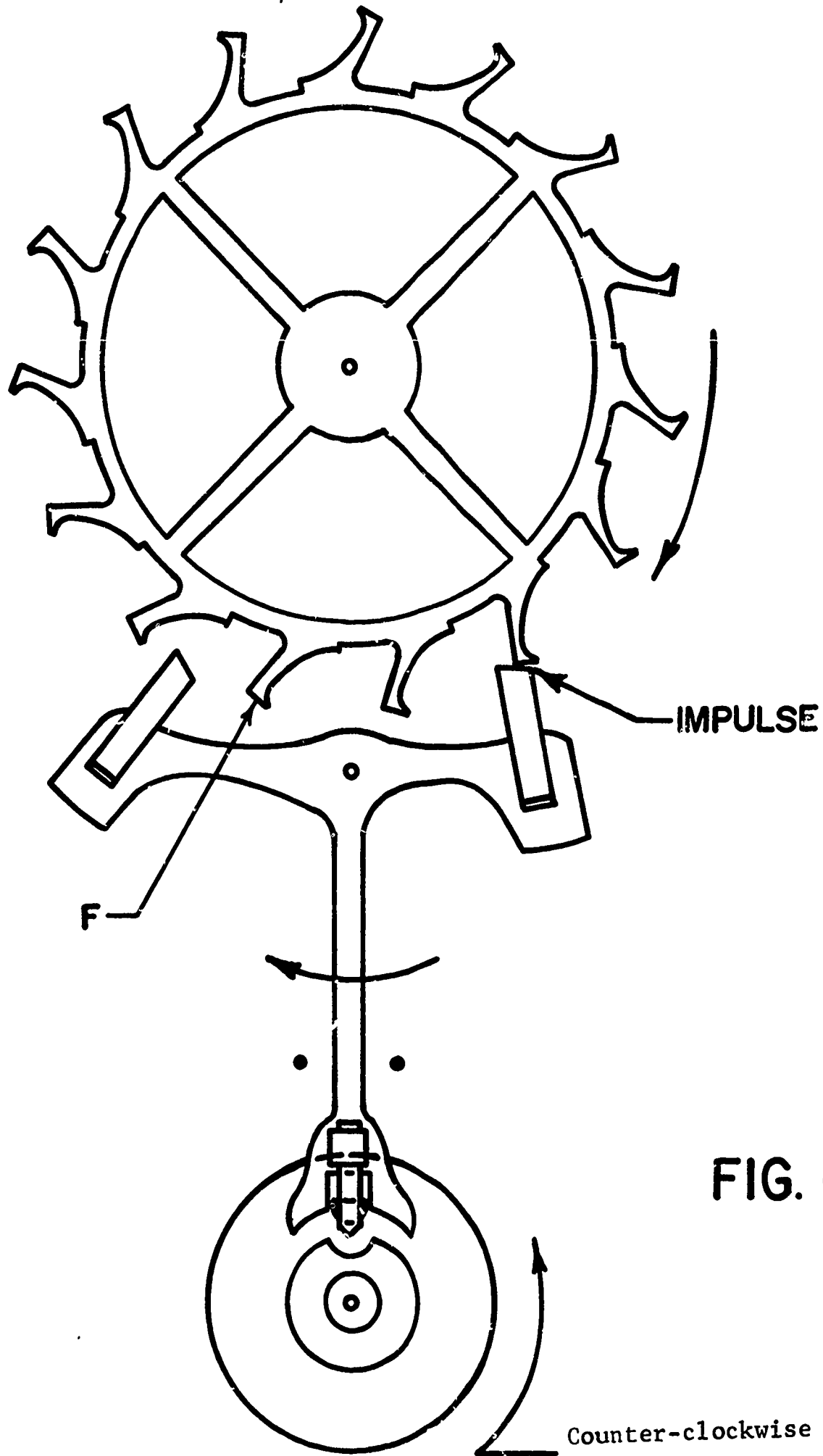

FIG. 4

Figure 4 shows an escape tooth on the impulse face of the receiving pallet stone. The pressure of the escape tooth on this impulse face forces the pallet fork to pivot in the direction of the arrow. The impulse will end when the escape tooth drops off or leaves the impulse face of the receiving pallet stone. Naturally, the pivoting of the pallet fork in the direction of the arrow will impulse the roller table via the roller jewel which is in the slot of the pallet fork at the time the impulse occurs.

As soon as the escape tooth leaves the receiving stone, the escape tooth "F" will lock on the discharge stone. This is known as "drop lock" (see figure 5).

FUNCTION OF THE ESCAPEMENT

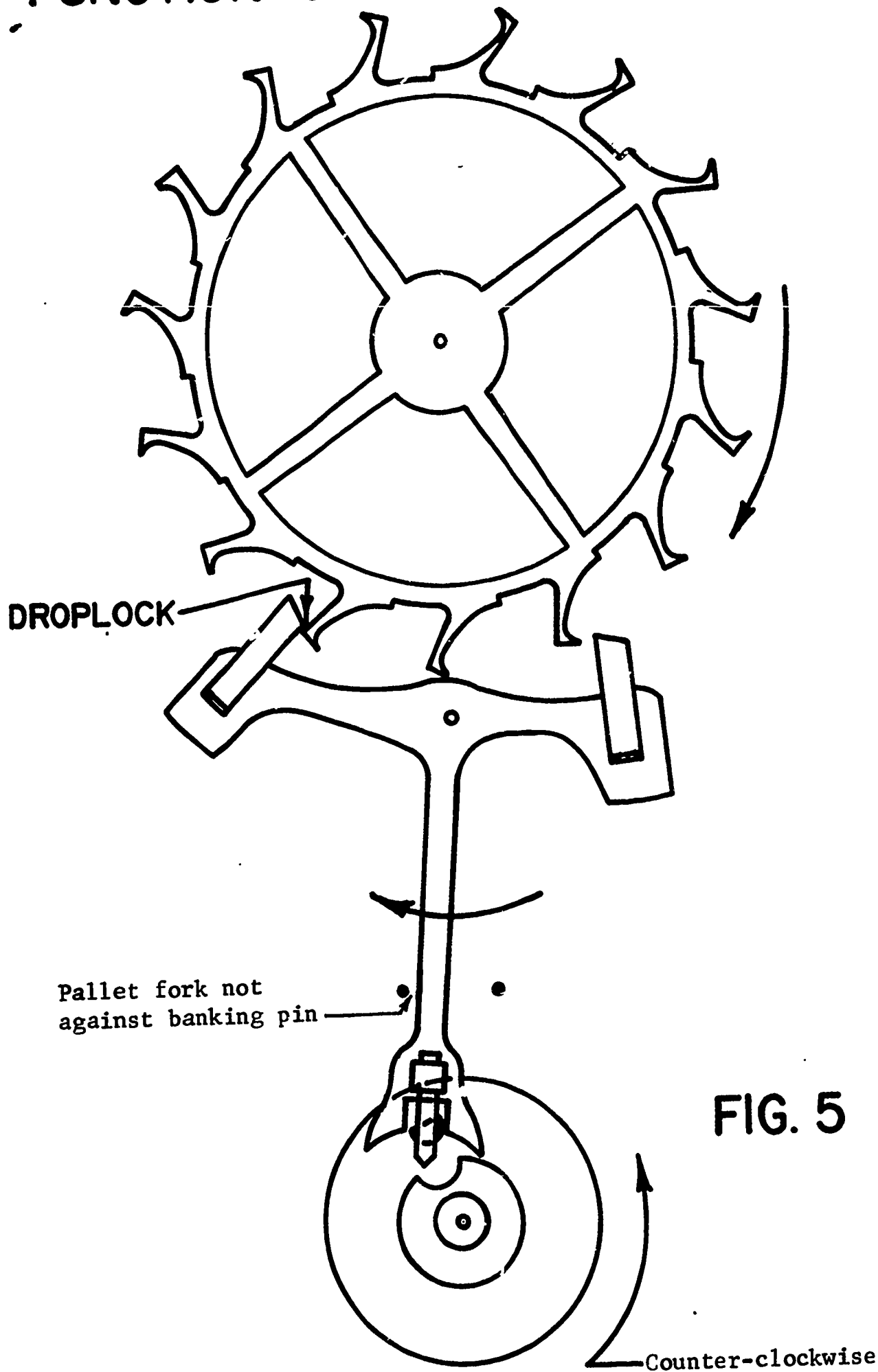

FIG. 5

Figure 5 shows the position of the pallet fork at the instant the escape tooth drops off the receiving stone. The lock that occurs when the pallet fork is in this position is called "drop lock". Note that the pallet fork has not yet moved against its banking pin.

After drop lock has occurred, the pallet fork will be drawn to the banking pin due to the pressure of the escape tooth against the locking face of the inclined pallet stone. The force that causes the fork to be drawn to the banking pin is termed "draw". (Reference: the force of draw is explained on pages 23 and 24). With the pallet fork against its banking pin (see figure 6), the roller table is then free of contact with the escapement, allowing the balance unit to turn freely.

FUNCTION OF THE ESCAPEMENT

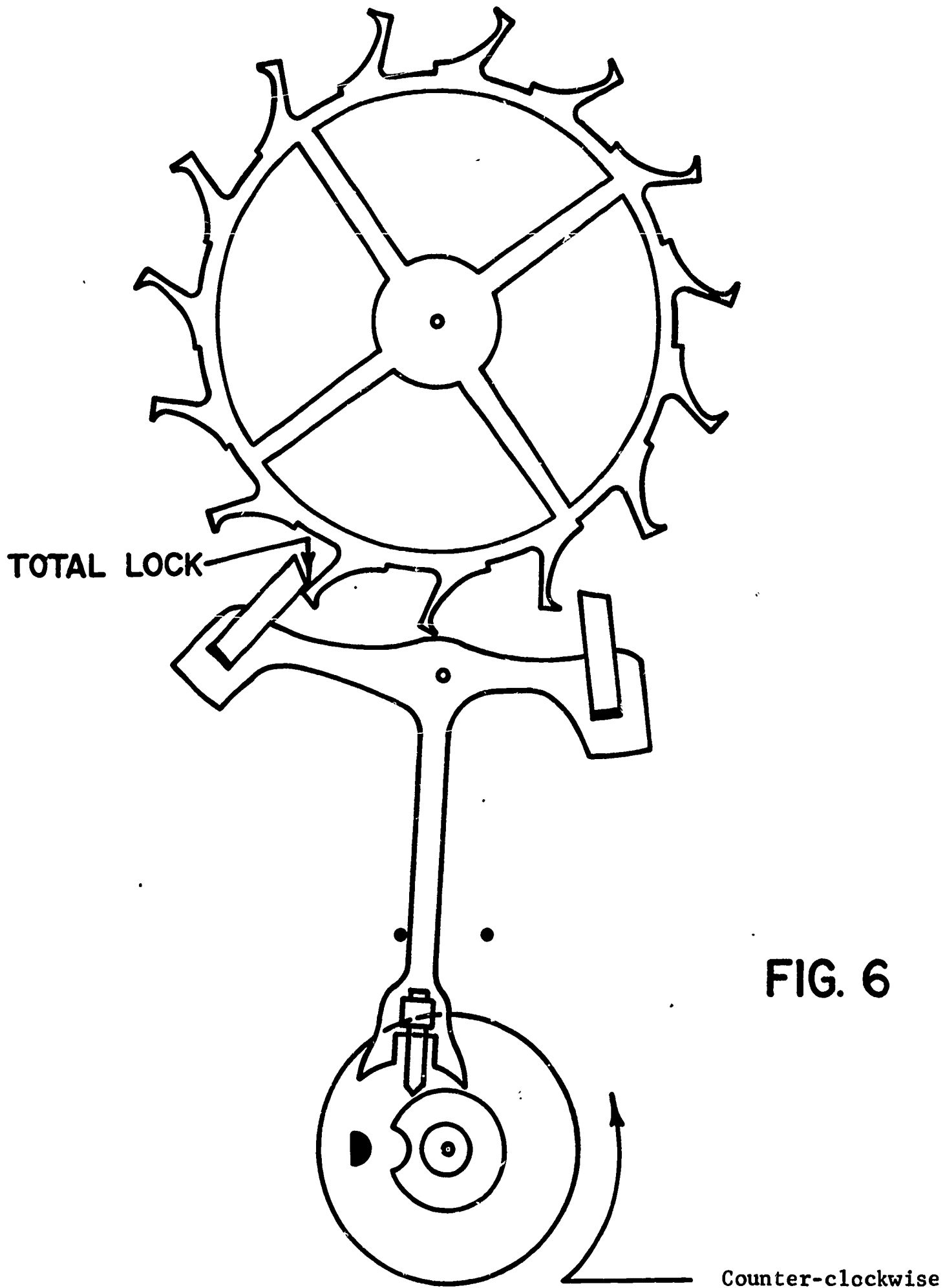

FIG. 6

Figure 6 shows total lock. Total lock consists of drop lock plus slide. Slide is the additional amount of lock that occurs after drop lock takes place, due to the pallet fork being drawn to its banking pin.

With the pallet fork against its banking pin (as shown in figure 6), the roller table unit can turn free of contact with the escapement. Then, as the balance assembly (not shown) reaches the end of its swing and the hairspring forces it to return, the roller jewel will again enter the pallet fork, as shown in figure 7.

FUNCTION OF THE ESCAPEMENT

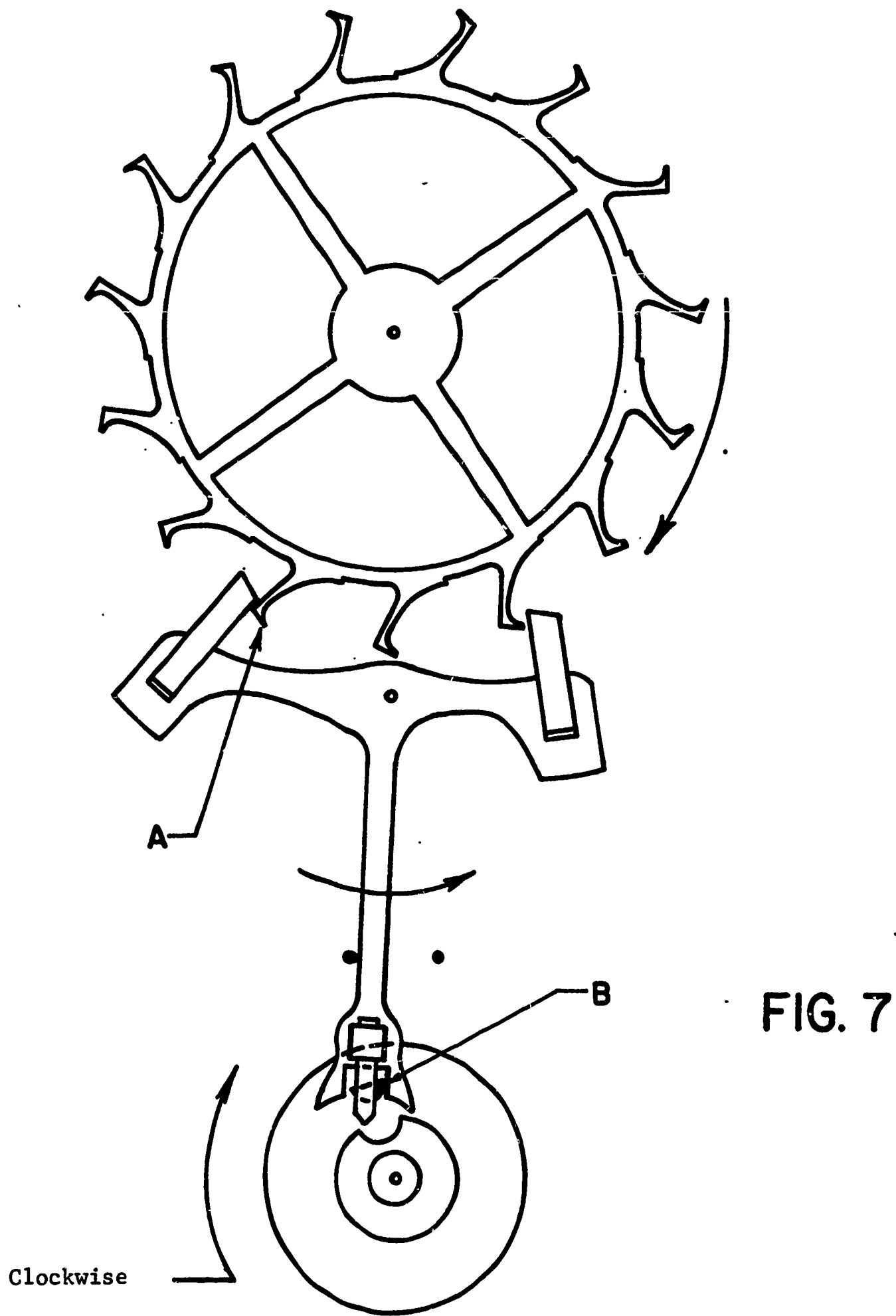

FIG. 7

Figure 7 shows the escape tooth "A" locked on the discharge pallet stone. The roller table is now turning clockwise by virtue of the hairspring (not shown) and the roller jewel "B" is at a position of contact in the slot of the pallet fork. Note: the pallet fork has not yet been moved from the banking pin. Now, as the roller table continues to turn, the roller jewel will move the pallet fork in the direction of the arrow. This will unlock the tooth "A" of the escape wheel (see figure 8).

FUNCTION OF THE ESCAPEMENT

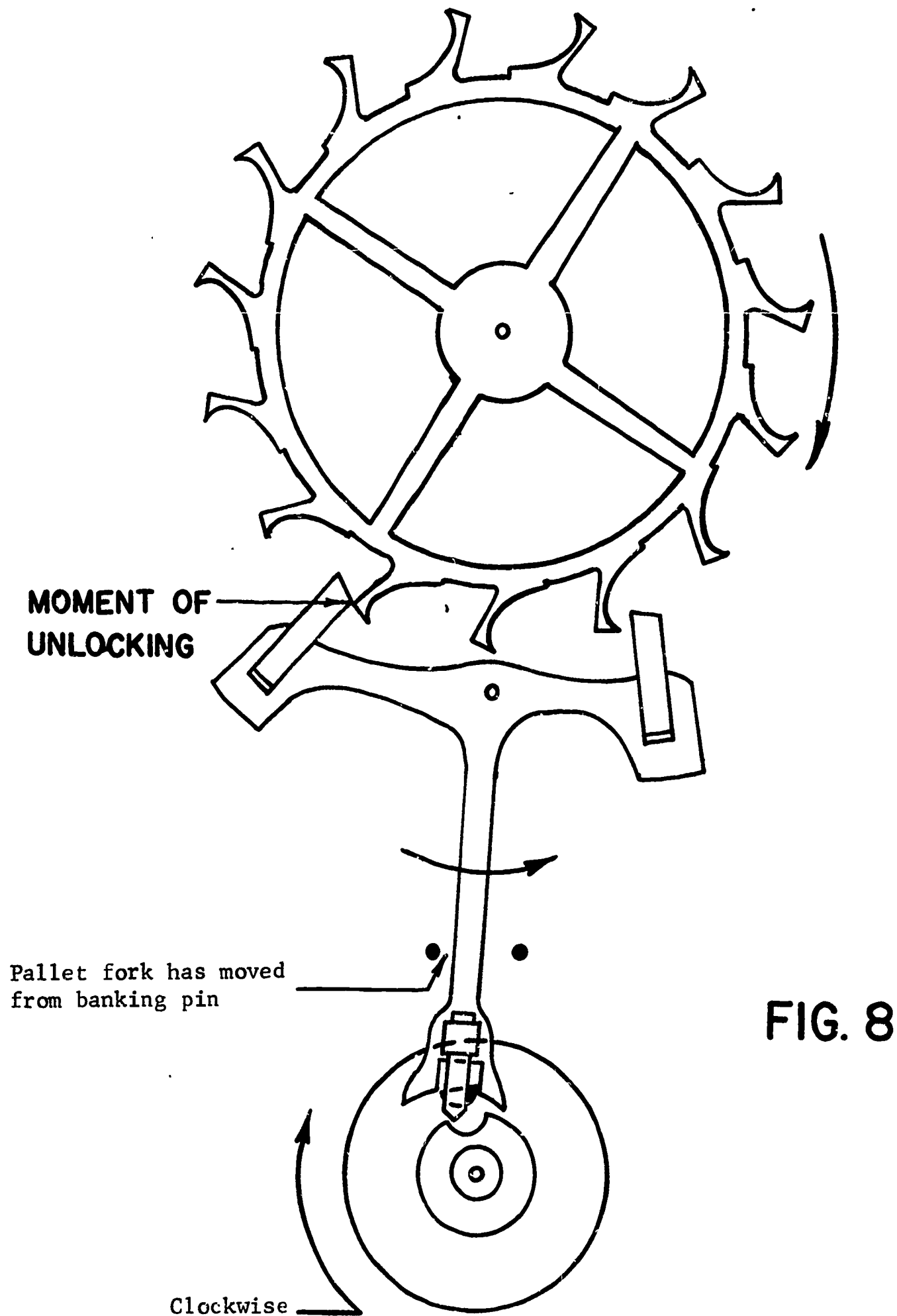

FIG. 8

Figure 8 shows the pallet fork when it has moved away from its banking pin to a point where the escapement is unlocking. It is the movement of the roller table and roller jewel clockwise that causes the escapement to be unlocked on the discharge side.

After the escape tooth is unlocked, it will travel up the impulse face of the pallet stone, thus causing the pallet fork to pivot on its arbor in the direction of the arrow, giving a kick or impulse to the roller jewel in a clockwise direction (see figure 9).

FUNCTION OF THE ESCAPEMENT

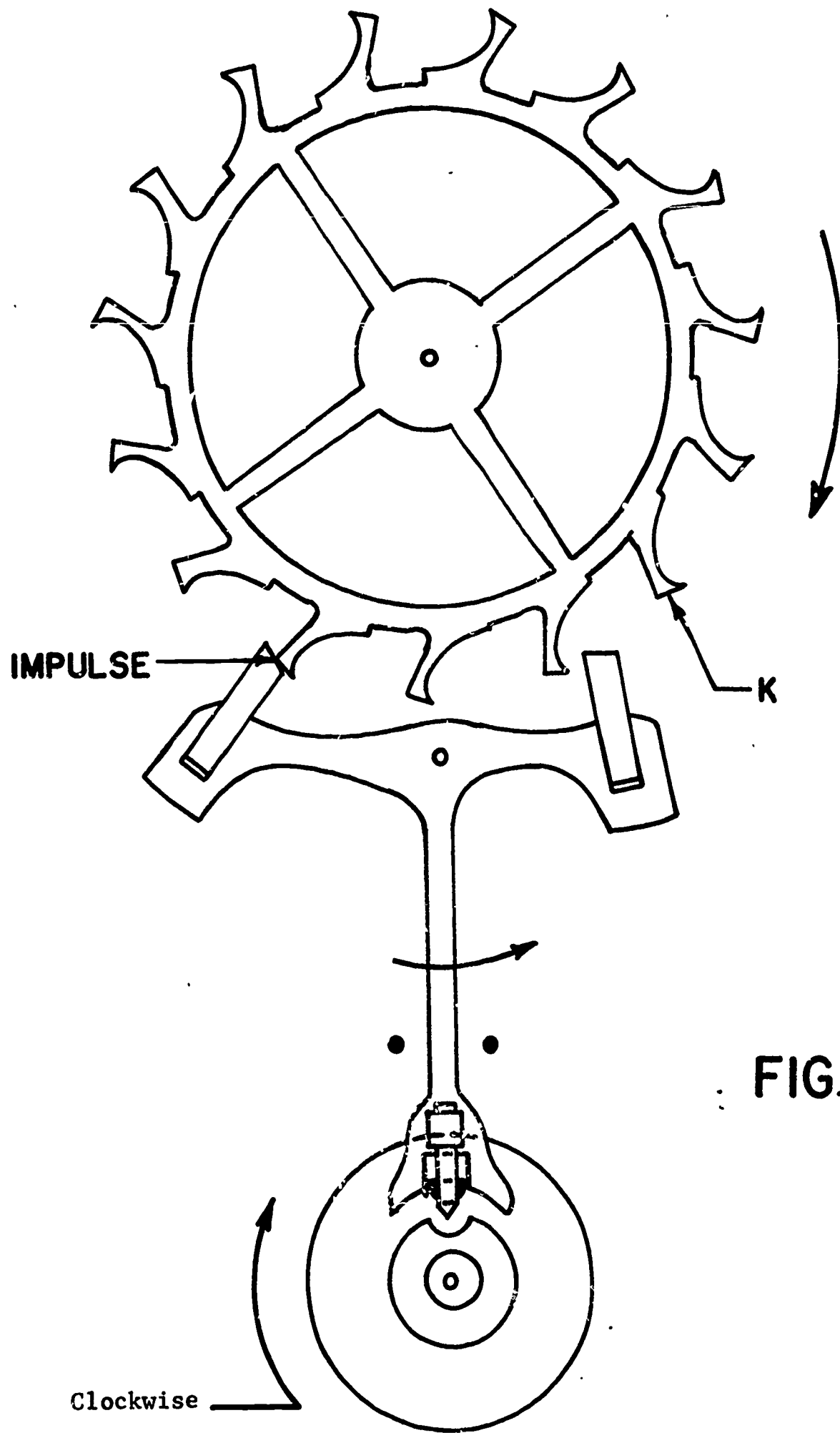

FIG. 9

Figure 9 shows an escape tooth on the impulse face of the discharge pallet stone. The pressure of the escape tooth on this impulse face forces the pallet fork to pivot in the direction of the arrow. The impulse will end when the escape tooth drops off or leaves the impulse face of the discharge pallet stone. Naturally, the pivoting of the pallet fork in the direction of the arrow will impulse the roller table via the roller jewel which is in the slot of the pallet fork at the time the impulse occurs.

As soon as the escape tooth leaves the discharge stone, the escape tooth "K" will lock on the receiving stone. This is known as "drop lock" (see figure 10).

FUNCTION OF THE ESCAPEMENT

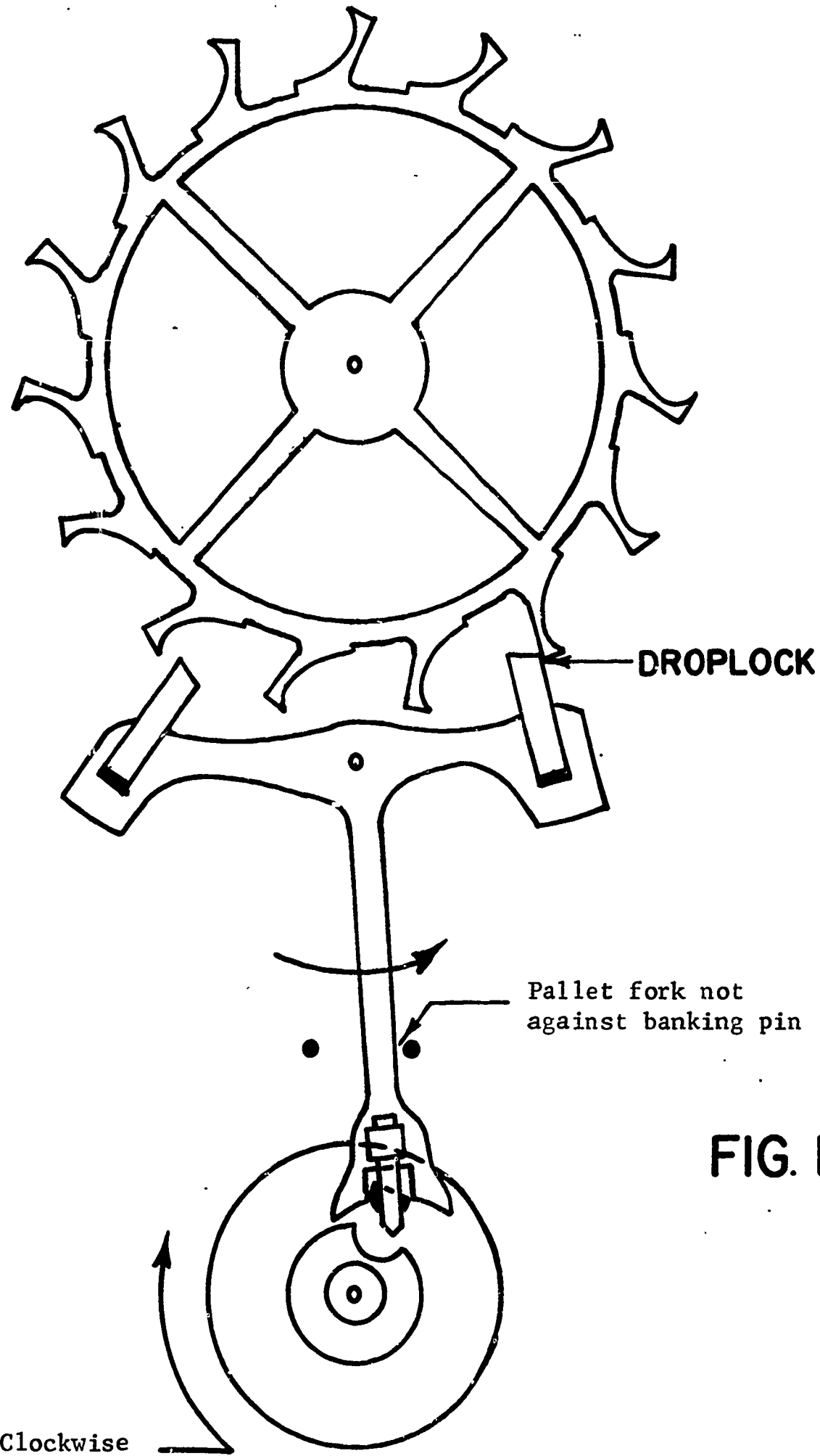

FIG. 10

Figure 10 shows the position of the pallet fork at the instant the escape tooth drops off the discharge stone. The lock that occurs when the pallet fork is in this position is called "drop lock". Note that the pallet fork has not yet moved against its banking pin.

After drop lock has occurred, the pallet fork will be drawn to the banking pin due to the pressure of the escape tooth against the locking face of the inclined pallet stone, and the escapement will return to the original starting position (see figure 11).

FUNCTION OF THE ESCAPEMENT

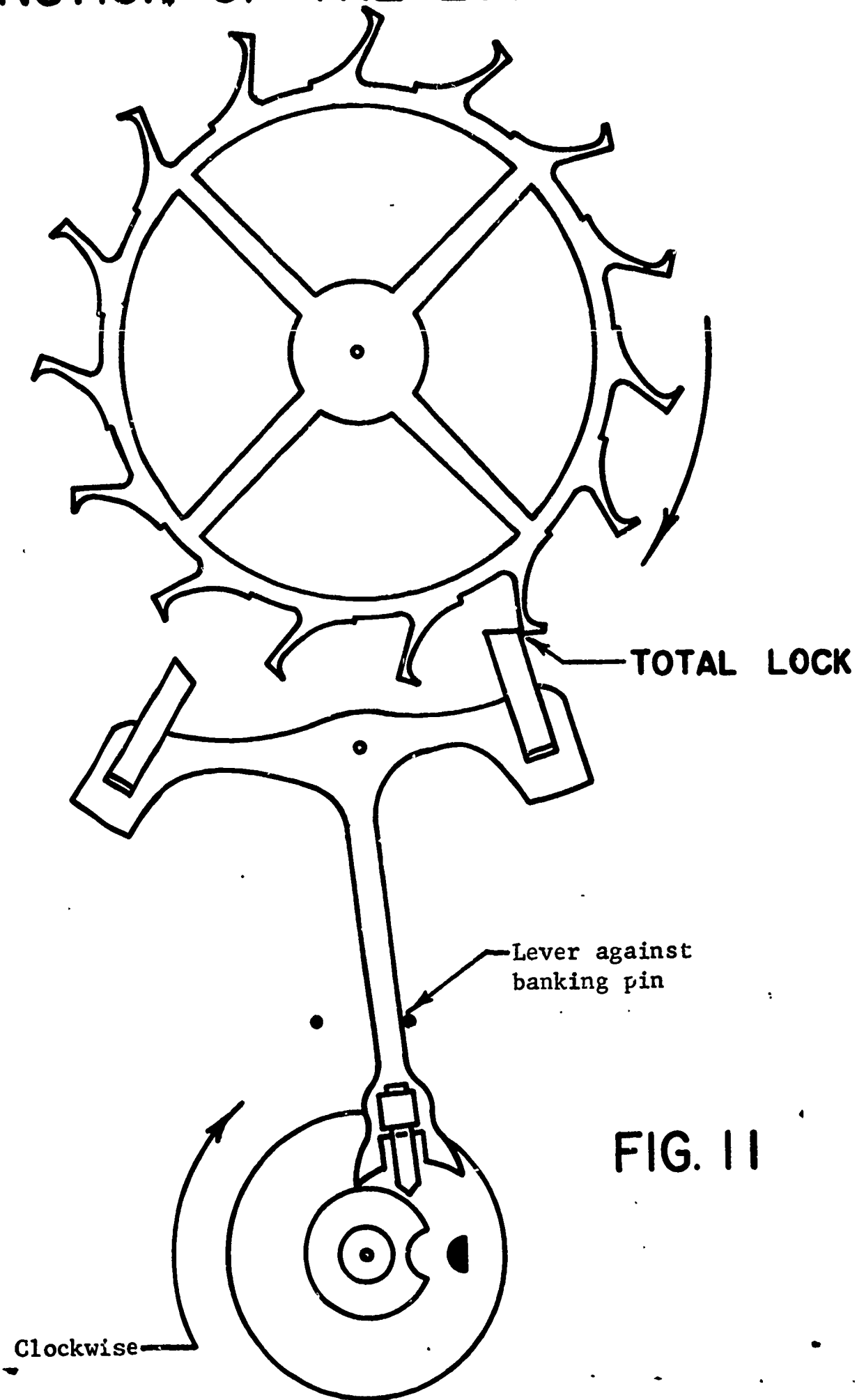

FIG. 11

Figure 11 shows total lock. Total lock consists of drop lock plus slide. Slide is the additional amount of lock that occurs after drop lock takes place, due to the pallet fork being drawn to its banking pin.

With the pallet fork against its banking pin (as shown in figure 11), the roller table unit can turn free of contact with the escapement. Then, as the balance assembly (not shown) reaches the end of its swing and the hairspring forces it to return, the roller jewel will again enter the pallet fork. This operation is repeated over and over again 18000 times per hour in the average watch. It goes without saying that in order for the escapement to function properly, it must be properly adjusted. The checks that must be made on the escapement to determine if it is properly adjusted and the corrective measures that must be taken to insure the proper operation of this mechanism, are illustrated and explained on the following pages.

Before proceeding, it is imperative that the student become familiar with the names given to designate the various locations on each part that has particular importance or relationship in reference to the escapement functions or adjustments. These are given in the eleven steps that follow. The blanks should be filled in by the students to make each sentence read correctly.

A.

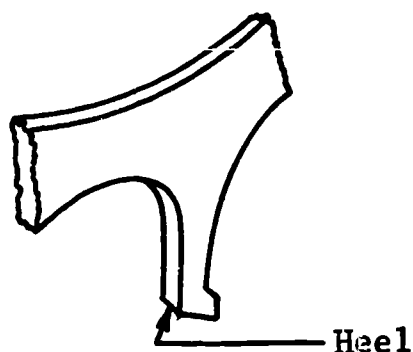

The _____ is the part of the escape tooth that comes to rest against the pallet stone at a position of lock.

B.

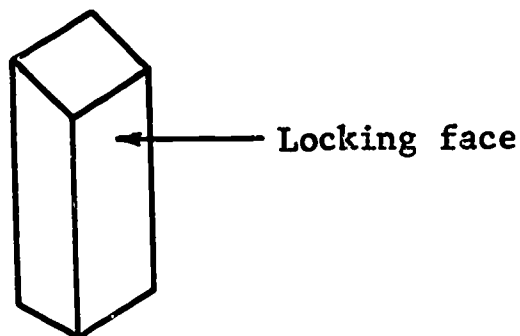

The _____ is the surface of the pallet stone on which the heel of the escape tooth locks.

C.

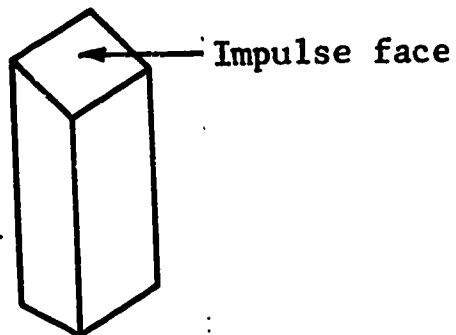

The _____ of the pallet stone is the surface that the heel of the escape tooth contacts to impulse the pallet fork.

D.

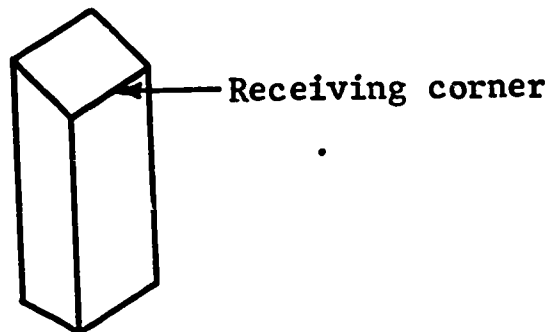

The _____ of the pallet stone is the corner at which the planes of the impulse face and locking face intersect.

E.

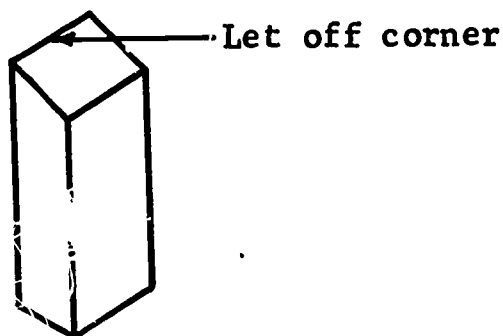

The _____ is the edge of the pallet stone from which the escape tooth drops off at the end of the impulse

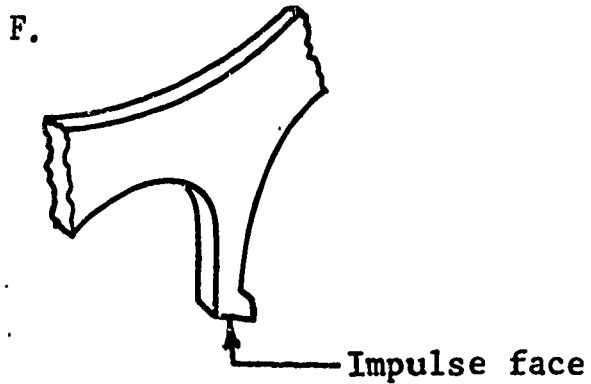

The _____ of the escape tooth is the surface of the escape tooth that rides across the let off corner of the pallet stone.

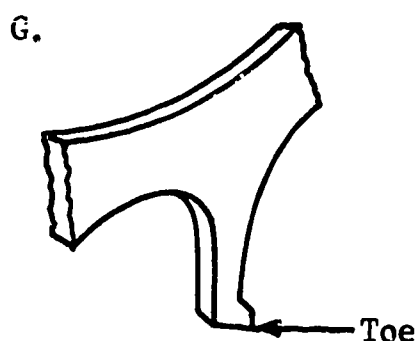

The _____ is the last point of the escape tooth to leave the _____ of the pallet stone.

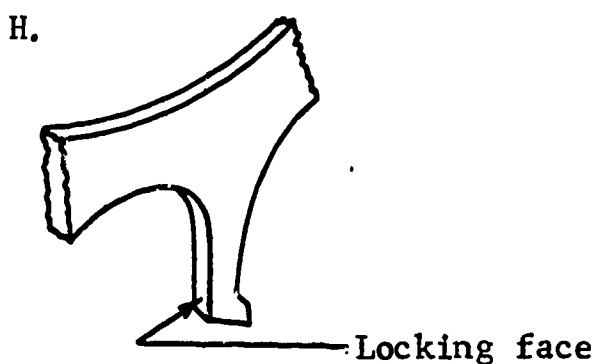

The _____ and the impulse face of the escape tooth at the point they intersect is known as the _____.

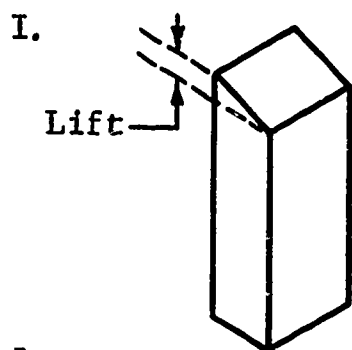

The _____ of the pallet stone is the slant or pitch of the _____.

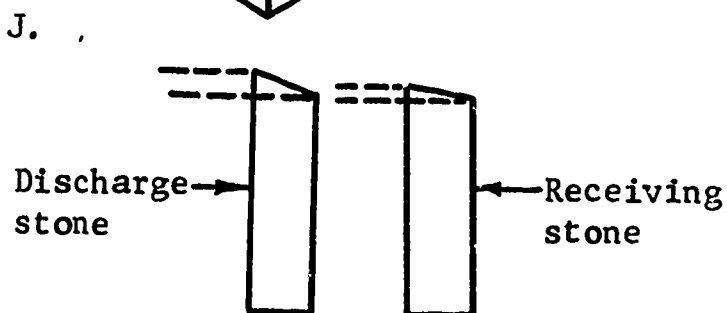

The _____ pallet stone has greater lift than the _____ pallet stone.

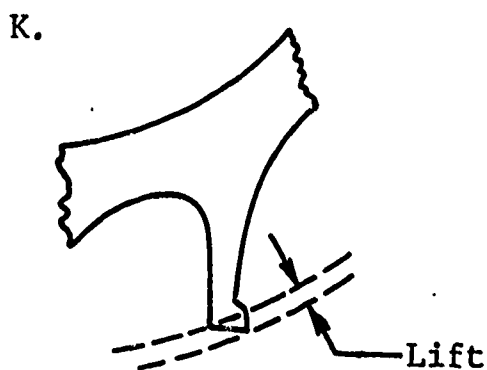

The _____ of the escape tooth is the angle or incline of the _____ of the escape tooth.

MATCHING STONES

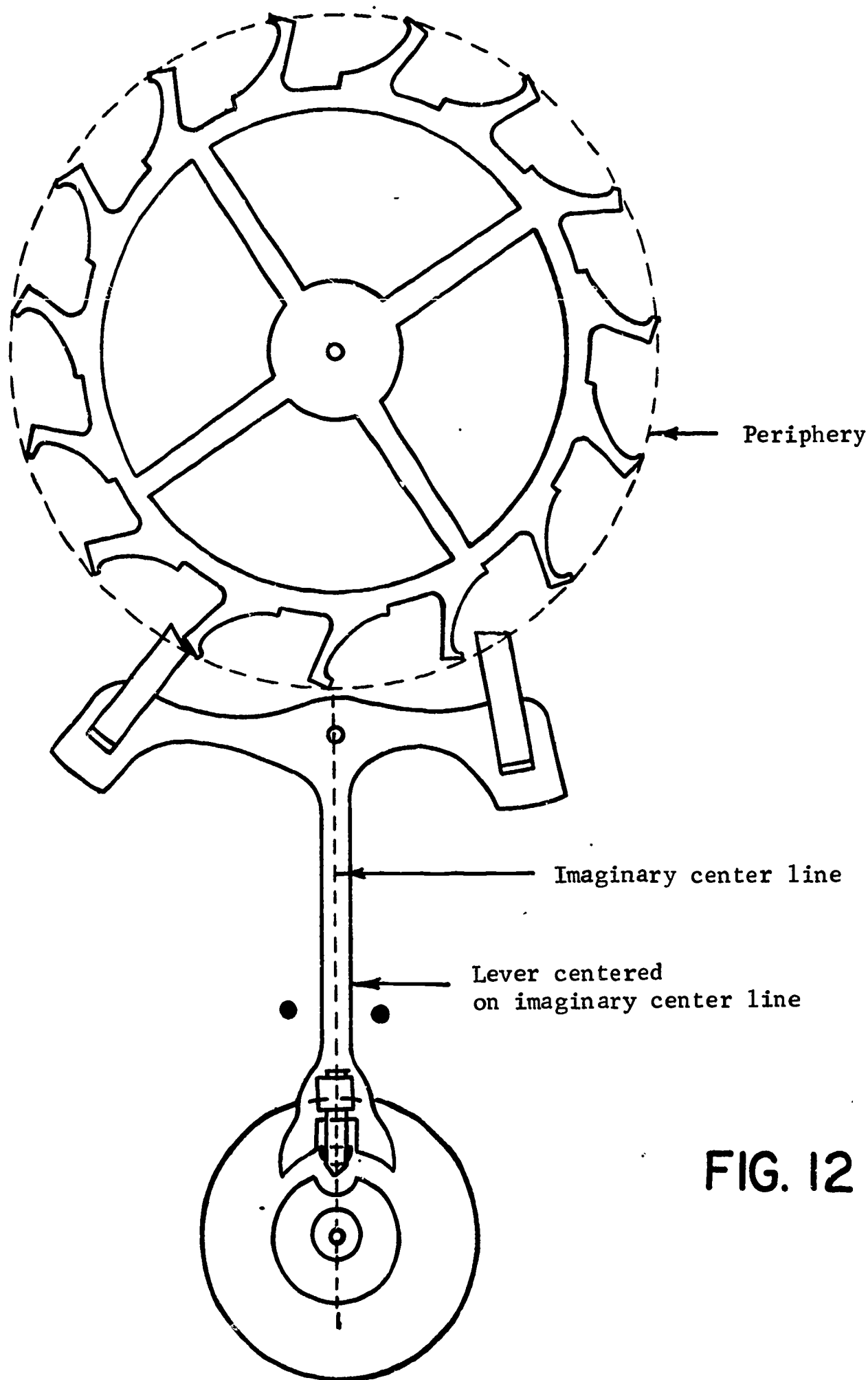
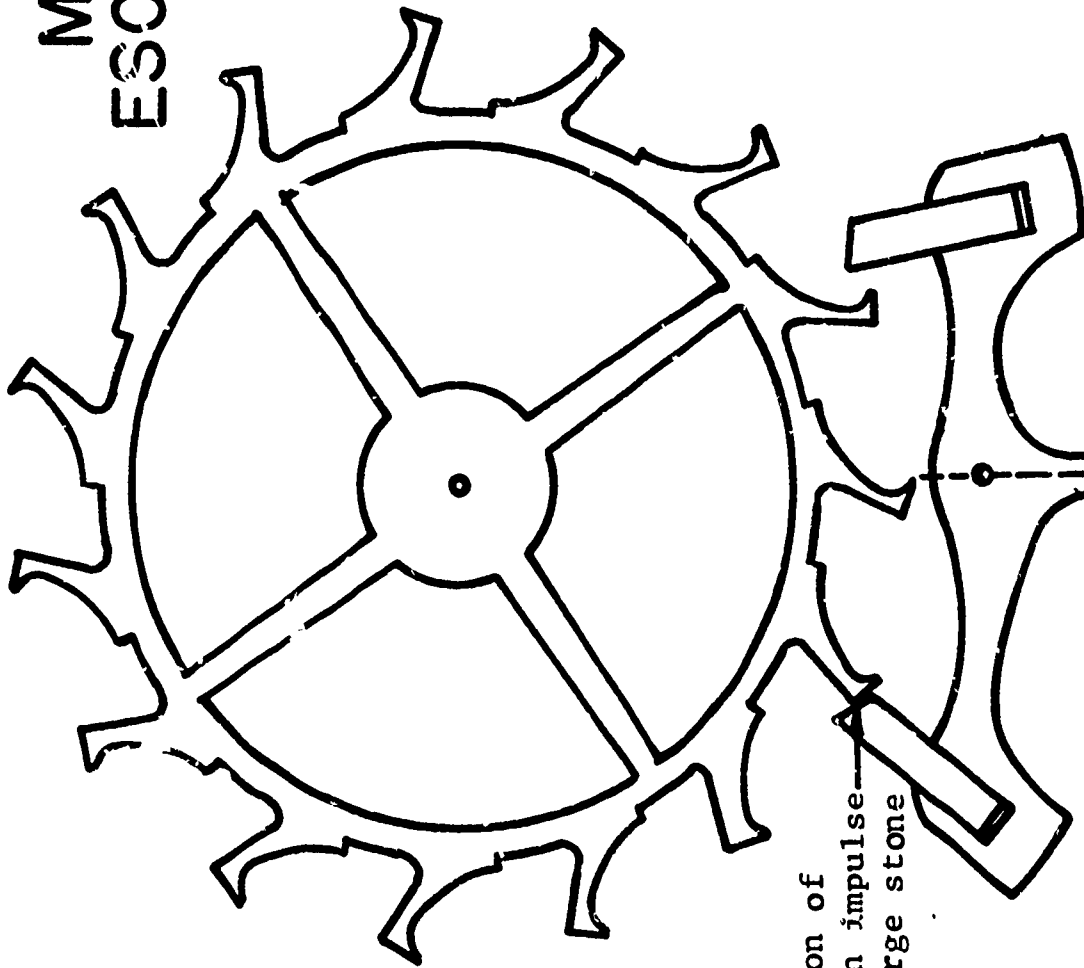

FIG. 12

Matching Stones - Figures 12 through 16

Matching stones is simply the adjustment of the pallet stones so that they will penetrate equally into the periphery of the escape wheel (see figure 12). The main goal is to have the pallet stones set so that the pallet fork will receive the same center of the impulse on each side of the imaginary center line in the escapement. The imaginary center line referred to in this text is an imaginary line extending through the centers of the pallet arbor and the balance staff. The procedure for matching the stones approximately is fully explained and illustrated in the following.

MATCHED ESCAPEMENT



Observe position of escape tooth on impulse face of discharge stone

FIG. 13

To check the pallet stones to see if they are matched, proceed as follows:

Move the lever of the pallet fork to center it on the imaginary center line in the escapement and observe the position of the escape tooth on the discharge stone (see figure 13).

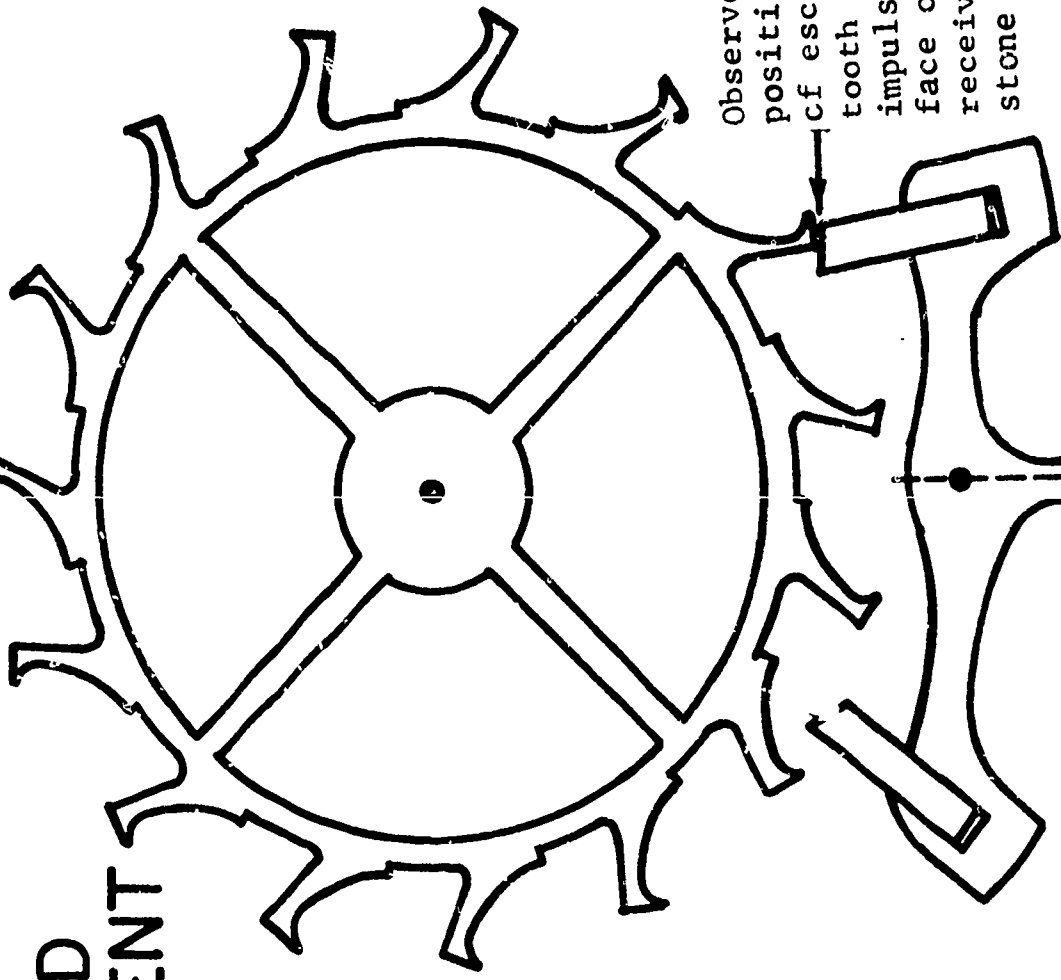

Observe position of escape tooth on impulse face of receiving stone

FIG. 14

Move the pallet fork to allow the escape tooth to drop off the discharge stone and bring the lever of the pallet fork back to center and check the position of the escape tooth on the impulse face of the receiving stone, (see figure 14). The pallet stones are matched when the escape wheel tooth travels up the impulse face of the receiving stone the same distance as it did on the discharge stone, whenever the fork is centered on the imaginary center line of the escapement, such as shown in figures 13 and 14.

Balance hole jewel

UNMATCHED ESCAPEMENT

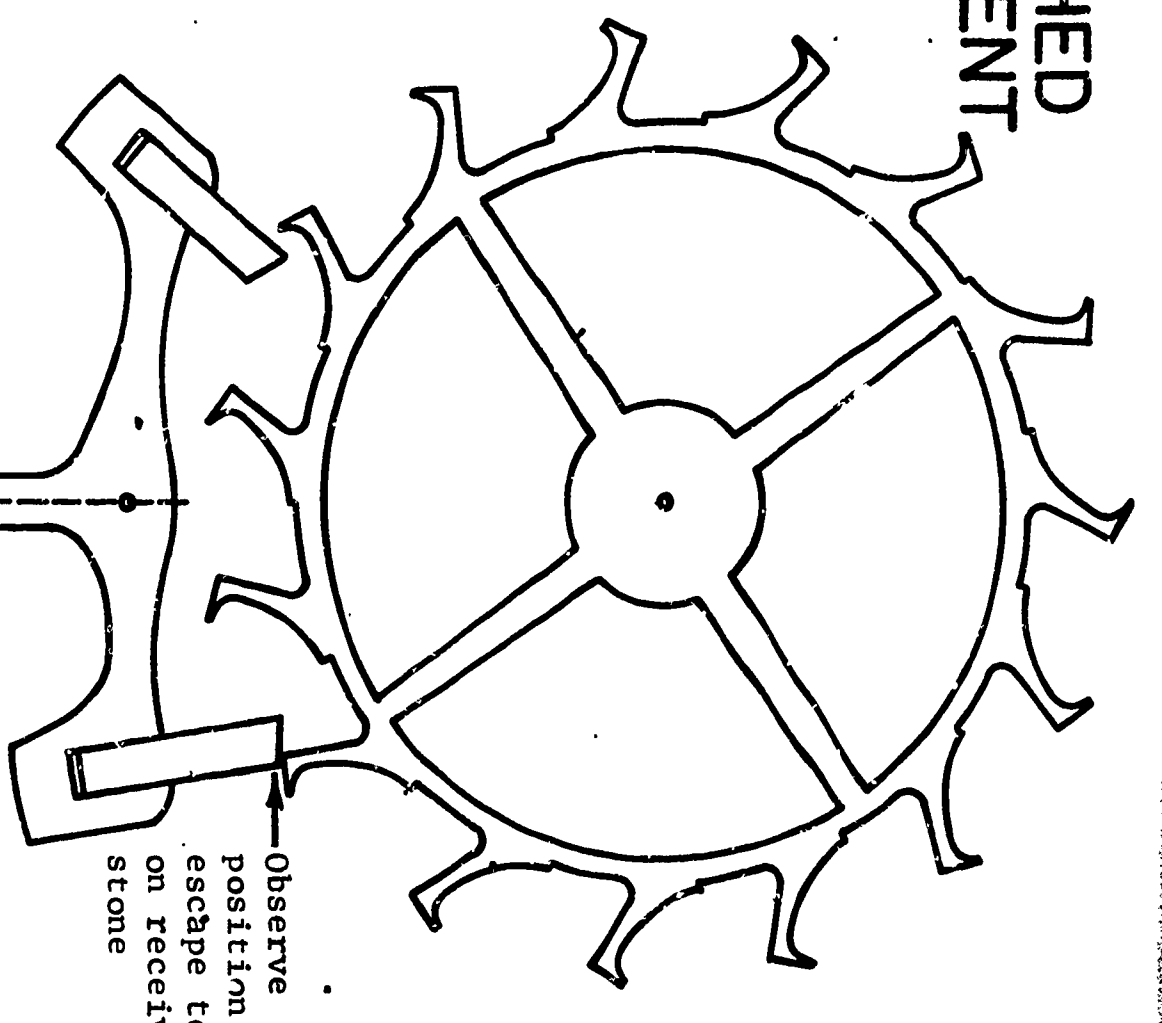
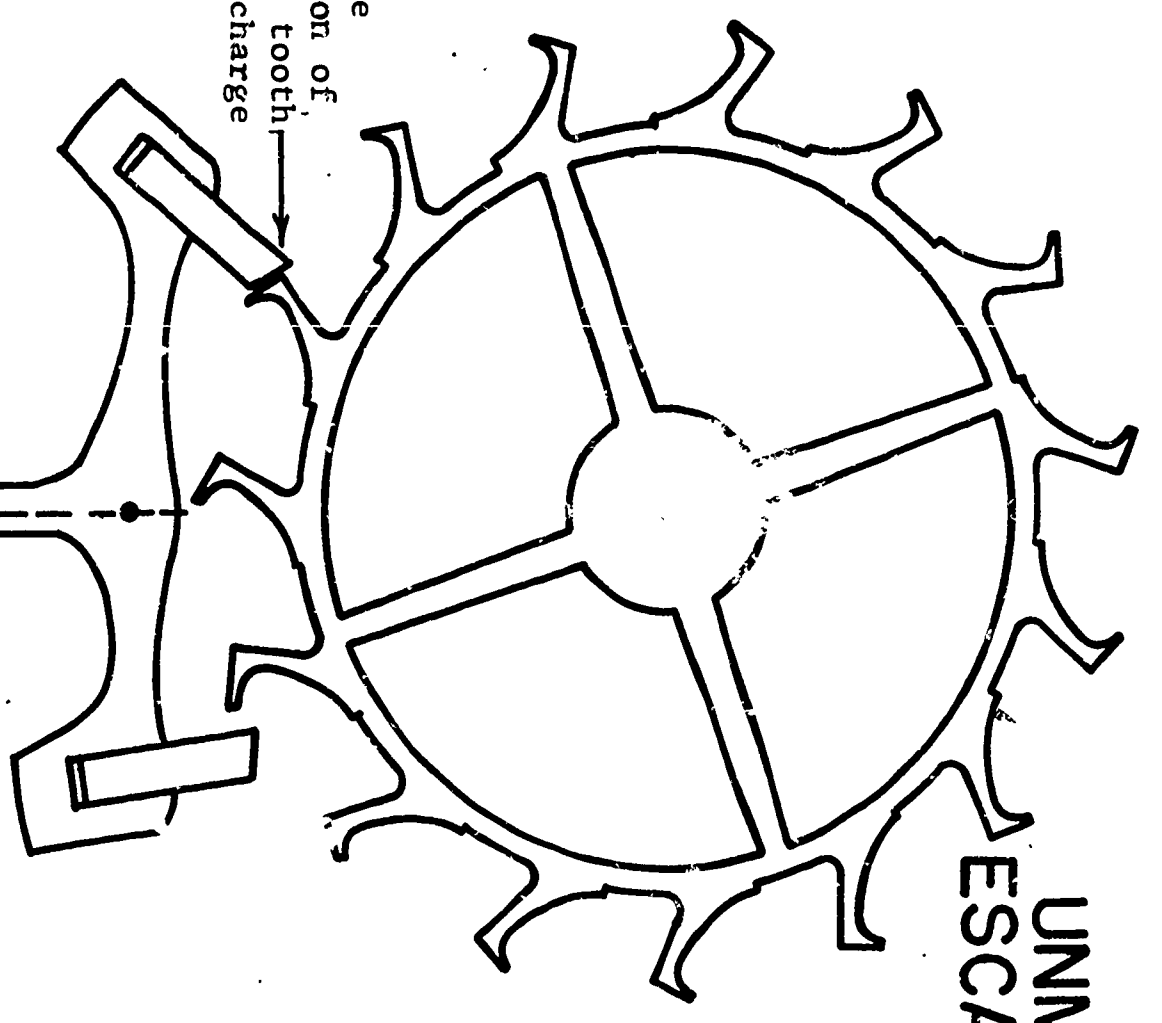
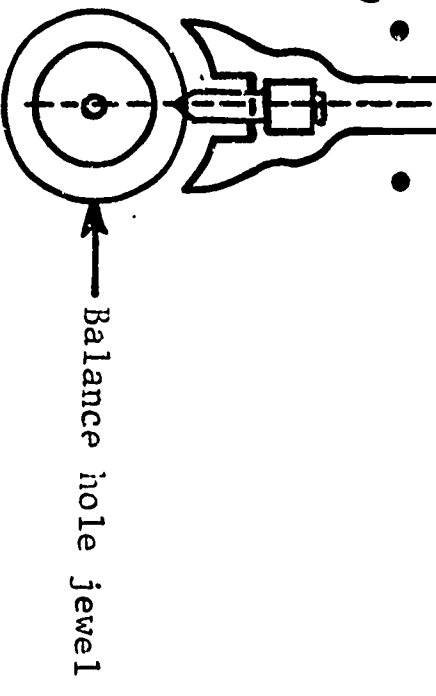
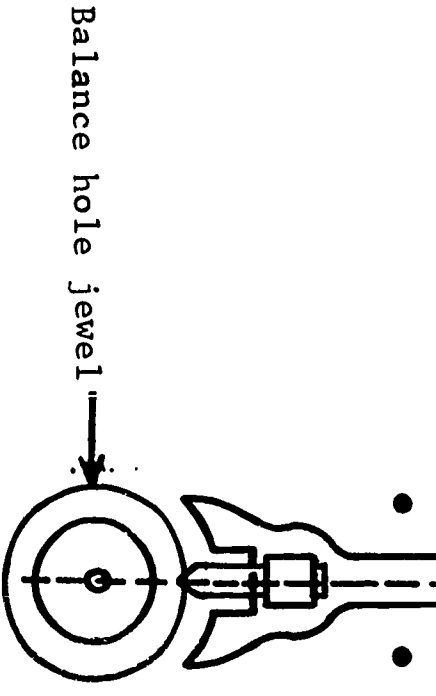

FIG. 15

FIG. 16



Figures 15 and 16 show an escapement condition in which the pallet stones are not matched. Observe that the lever of the pallet fork is centered on the imaginary line, but the escape teeth are not in the same position on the receiving and discharge stone. The escape tooth on the discharge stone (figure 15) is nearer the let off corner of the pallet stone than the escape tooth on the receiving stone (figure 16). To correct this condition and bring the stones in to match, one of the pallet stones must be adjusted. The adjustment of a pallet stone is accomplished by moving it either in or out of its slot (see figure 17).

MATCHING STONES

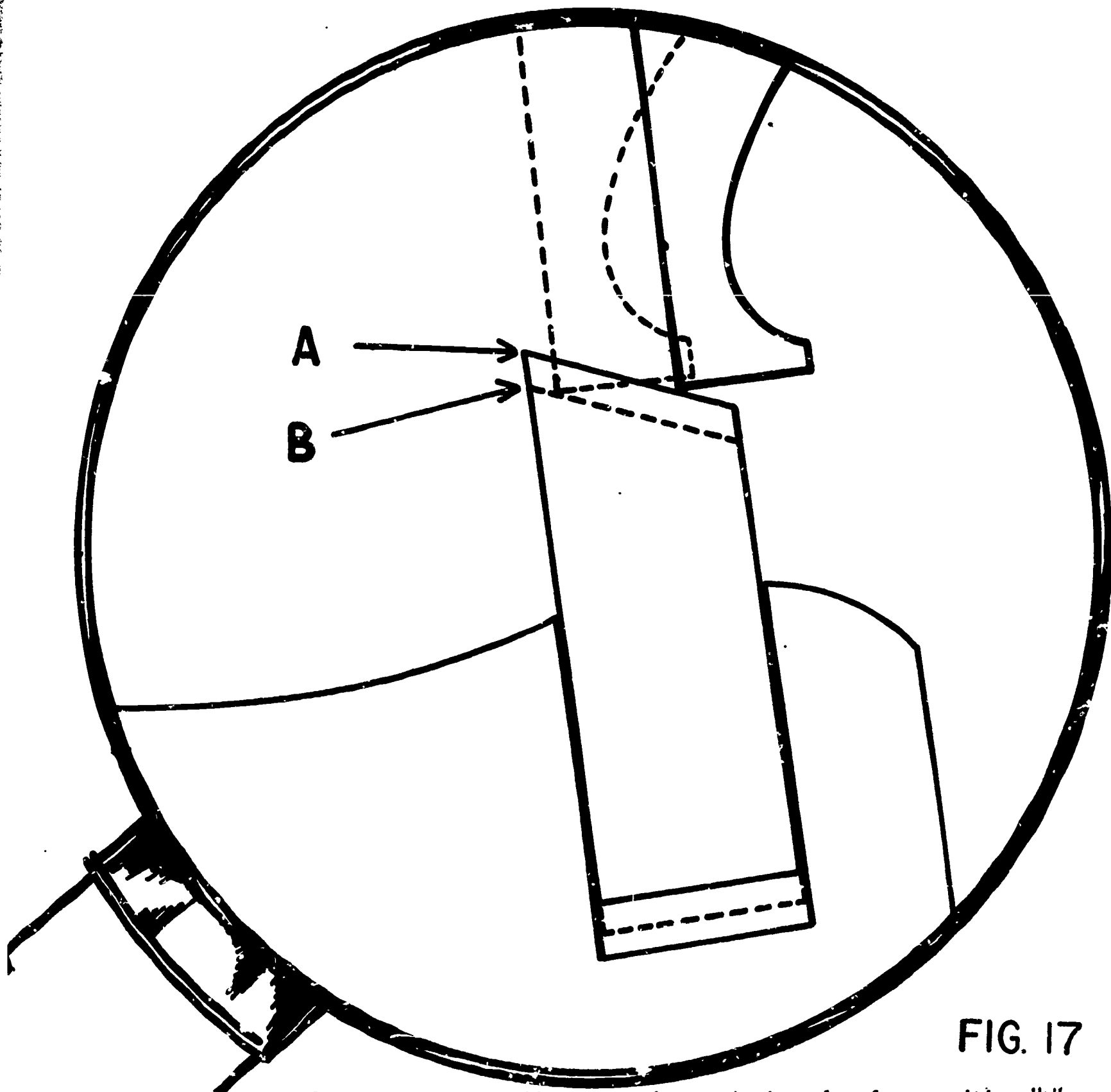

FIG. 17

Figure 17 shows that by moving a pallet stone deeper in its slot from position "A" to "B", as indicated by the dotted lines, the escape tooth will then move closer to the let off corner of the pallet stone. Now go back to figures 15 and 16 and apply this information to determine what correction should be made to correct the condition illustrated. It is obvious that to correct the out of match condition shown in figures 15 and 16, there are two possible corrective measures that can be taken: (1) the receiving stone can be set deeper in its slot so that the escape tooth will move to a position identical to that shown on the discharge side; and (2), equally as good, the receiving stone could be left alone, but the discharge stone must then be moved out of its slot so that the escape tooth will move to a position that will match that of the receiving side.

Summary

It is sufficient at this point that the student understand just exactly what is meant by matching stones and that if the pallet stones are found to be out of match, there are always two possible corrective measures that can be taken to bring about the desired results. 174

DROPLOCK

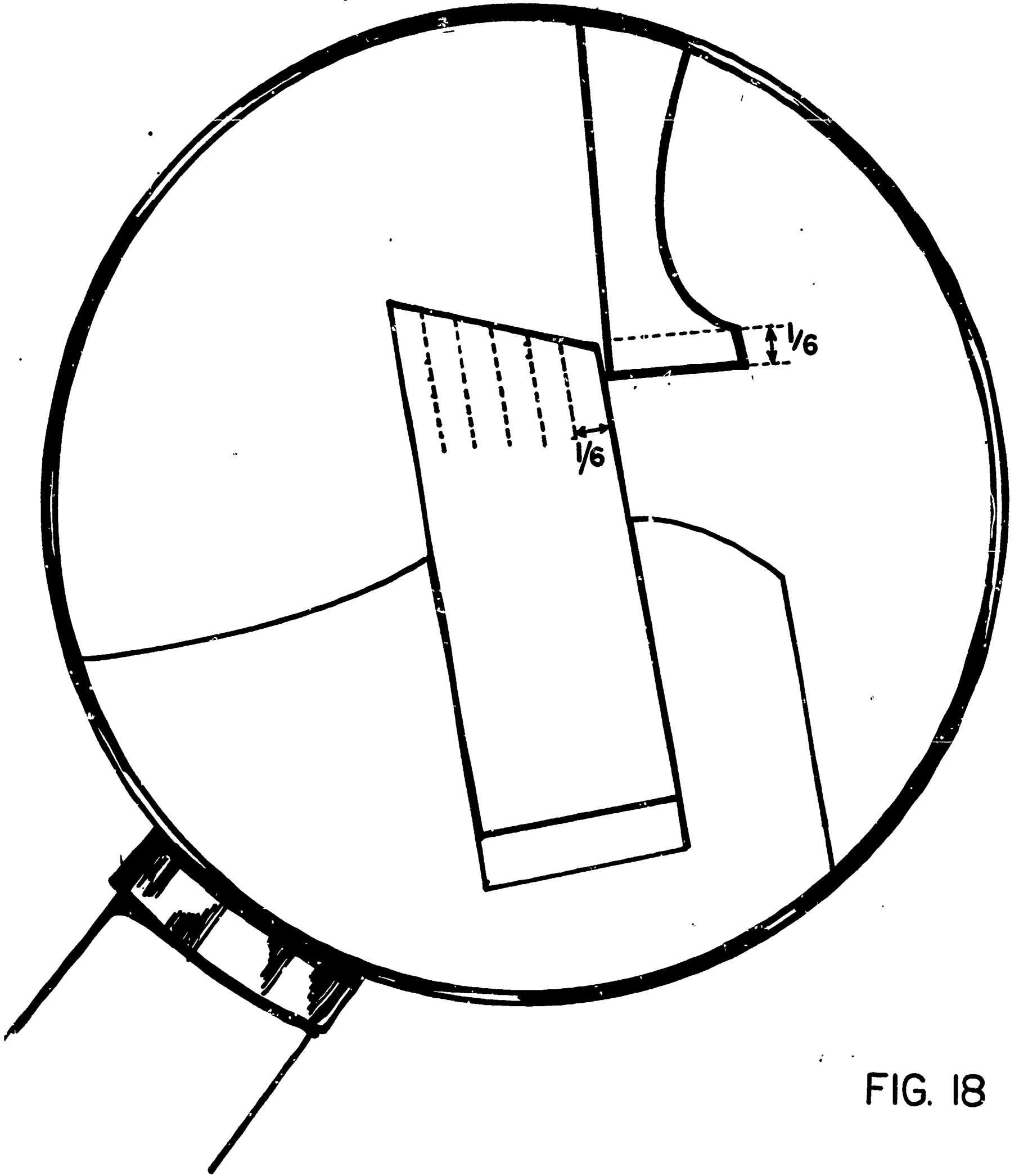

FIG. 18

DROP LOCK

- A. Checking the Match of the pallet stones is necessary to determine if the pallet stones are penetrating equally into the periphery of the escape wheel.
- B. Checking Drop Lock is the method used to determine the proper depth of penetration of the pallet stones into the periphery of the escape wheel.

Figure 5 shows drop lock on the discharge stone, and figure 10 shows drop lock on the receiving stone. Drop lock is checked by moving the pallet fork slowly until the instant the escape tooth drops off one stone. At that instant, the pallet fork should be held stationary and the amount of lap of the tooth over the locking face of the stone is the drop lock. This check should be made on each stone. The drop lock is correct when it is about $1/6$ the width of the pallet stone (see figure 18). To increase drop lock the pallet stones can be moved deeper into the periphery of the escape wheel. On the other hand, moving the pallet stones to reduce their depth of penetration into the periphery of the escape wheel will result in decreasing drop lock.

Important:

When moving the pallet stones, to acquire the proper amount of drop lock, one must continually re-check the matching of the pallet stones to be sure that they are not being moved out of match.

Summary

At this point it is sufficient for the student to understand how drop lock can be increased or decreased, the proper amount of drop lock, and that at no time should drop lock be corrected at the expense of creating an unmatched condition of the pallet stones.

**INSIDE AND
OUTSIDE DROP**

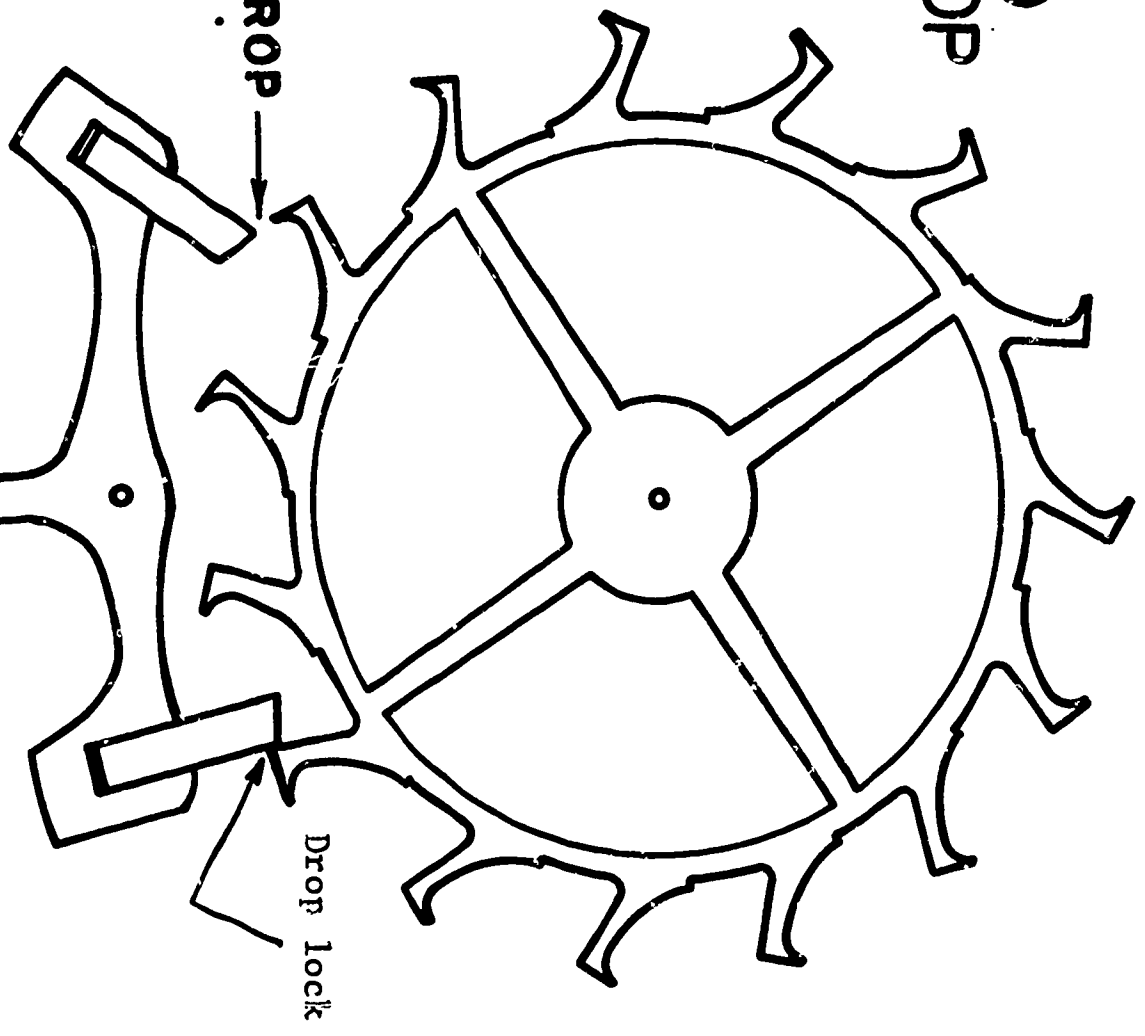
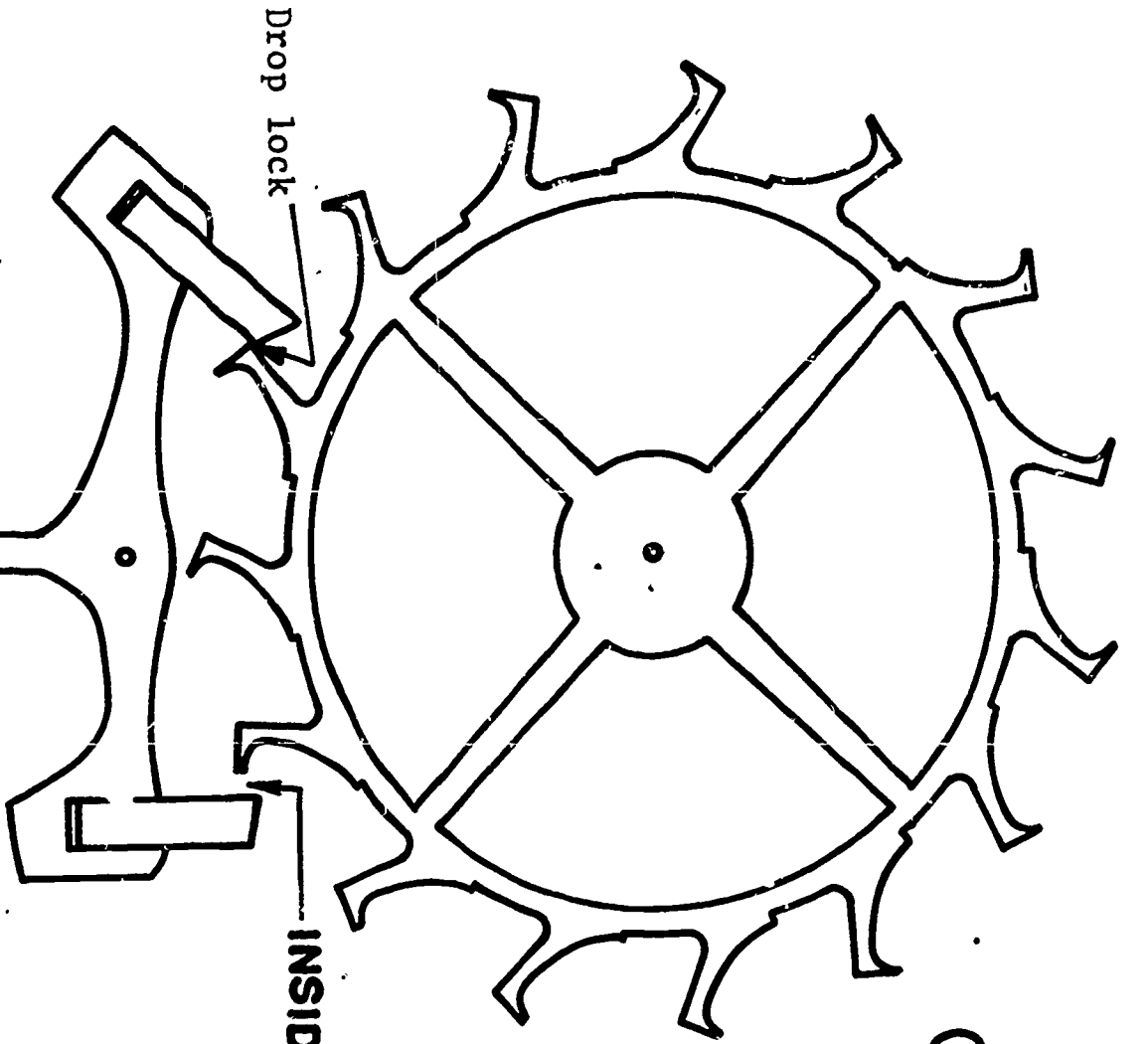

FIG. 19

FIG. 20

Inside and Outside Drop

Figure 19 and figure 20 show inside and outside drop. When inside and outside drop are correct, such as shown in figures 19 and 20, the inside drop is equal to the outside drop. Inside drop is the space that exists between the toe of the escape tooth and the receiving stone when the pallet fork is at the point of drop lock on the discharge side (see figure 19). Outside drop is the space that exists between the toe of the escape tooth and the discharge stone when the pallet fork is at a point of drop lock on the receiving side (see figure 20).

INSIDE AND OUTSIDE DROP

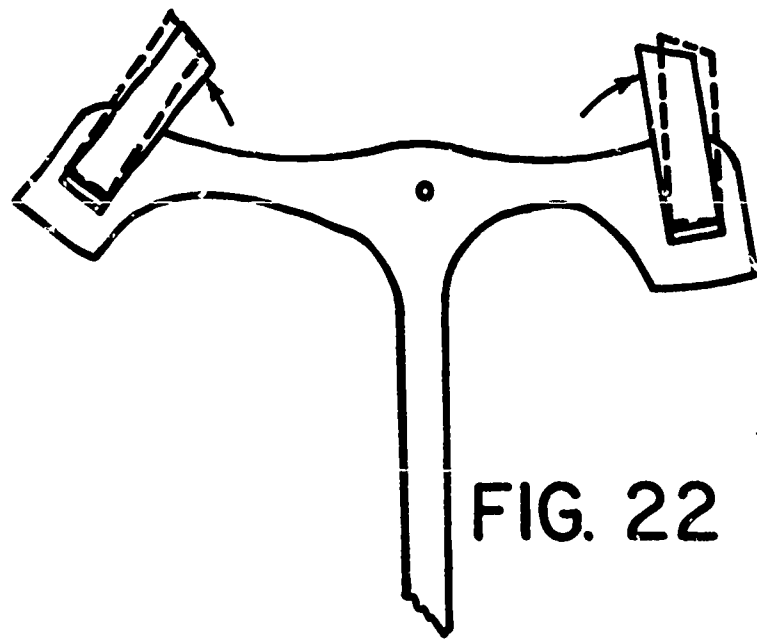
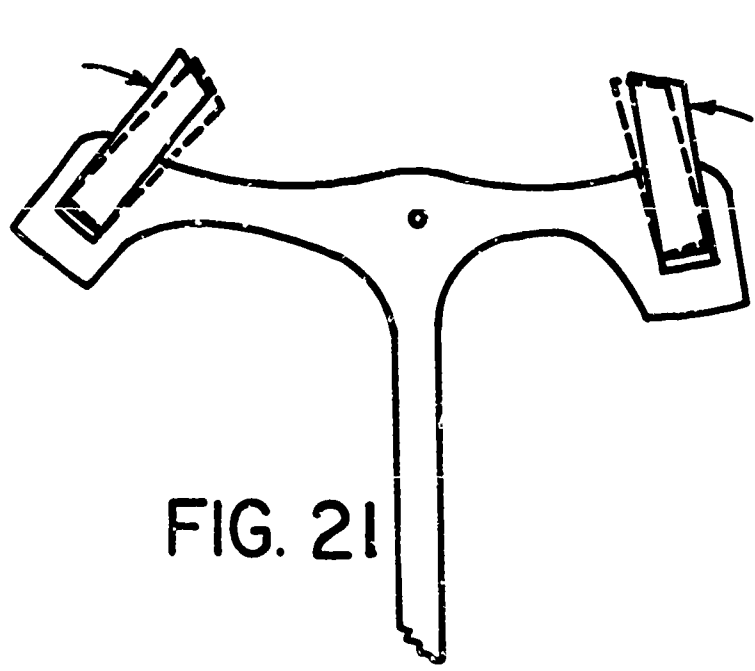

Inside and outside drop can be changed by tilting the stones as shown in figures 21 and 22. One must, however, be aware that by tilting one or both pallet stones to increase the amount of outside drop such as shown in figure 21, the amount of inside drop will be reduced. On the other hand, the tilting of one or both pallet stones as indicated in figure 22, the amount of inside drop will be increased and the amount of outside drop will be reduced. Today, pallet stones are fitted rather neatly into their slots. Therefore, inside and outside drop are rarely found to be unequal.

Summary

At this point, it is sufficient for the student to understand how inside and outside drop can be altered and that it is correct when the inside and outside drop are equal to one another.

DRAW

Draw

After drop lock has occurred, the pallet fork will be drawn to the banking pin due to the pressure of the escape tooth against the locking face of the inclined pallet stone. Figures 23 and 24 illustrate the force of draw. Figure 23 shows the direction of thrust of a polished inclined block setting on a polished surface when a direct downward pressure is applied to the inclined plane. Figure 24 shows that this same effect results on the locking face of the pallet stone when pressure is applied in the same way. Of course, in the escapement it is the heel of the escape tooth that exerts the pressure on the locking face of the pallet stone, but the results are the same. That is, the fork is forced to move and comes to rest against its banking pin.

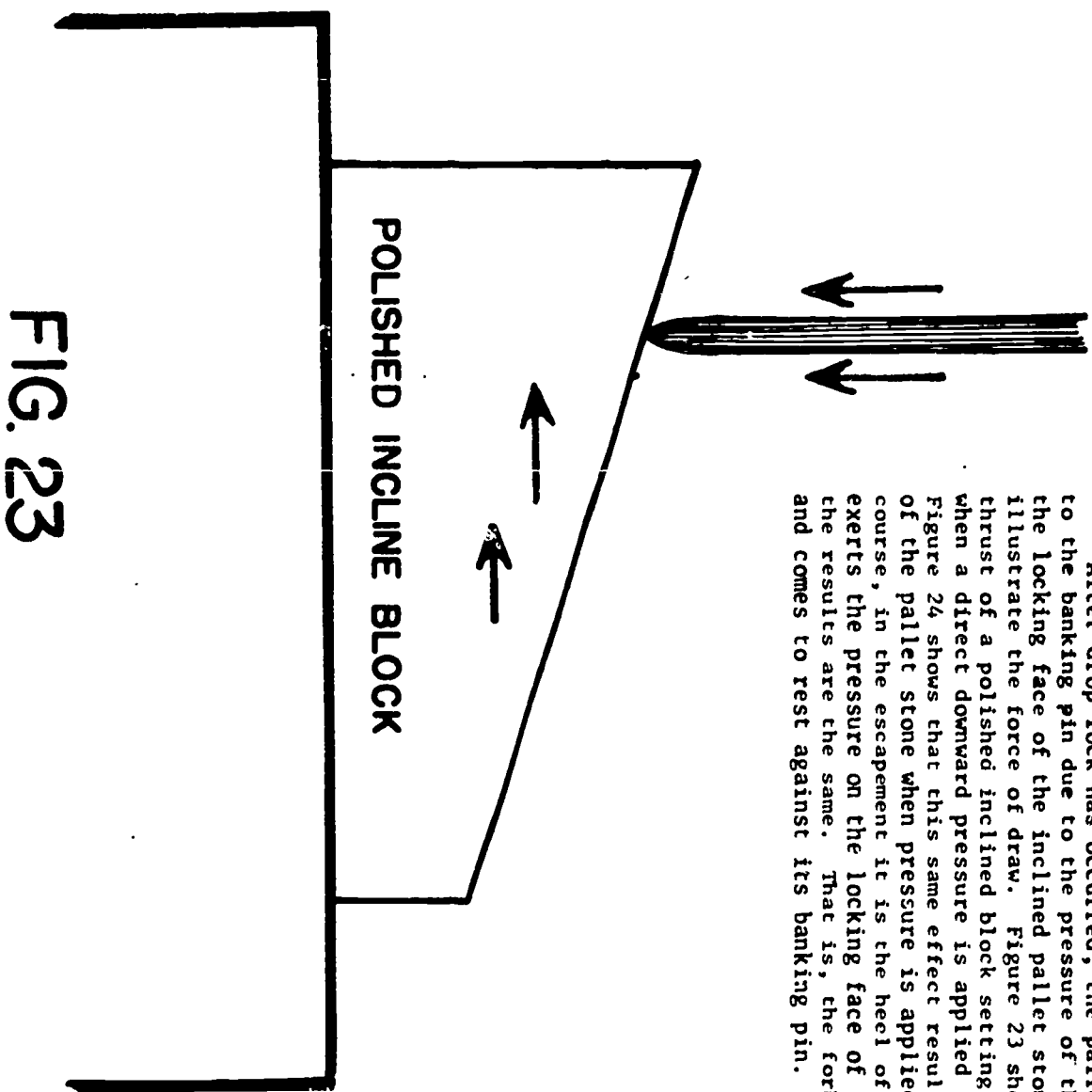

FIG. 23

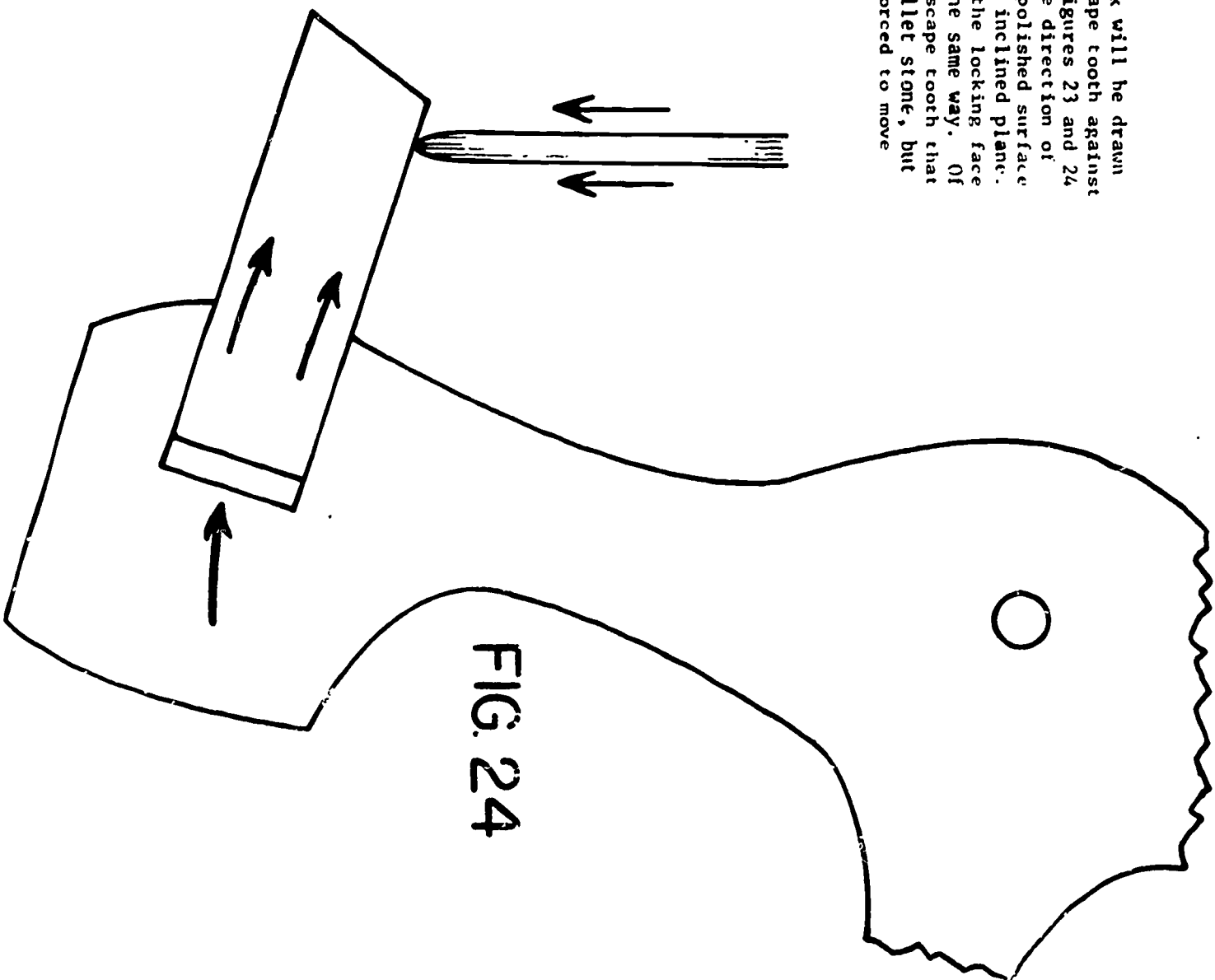

FIG. 24

DRAW

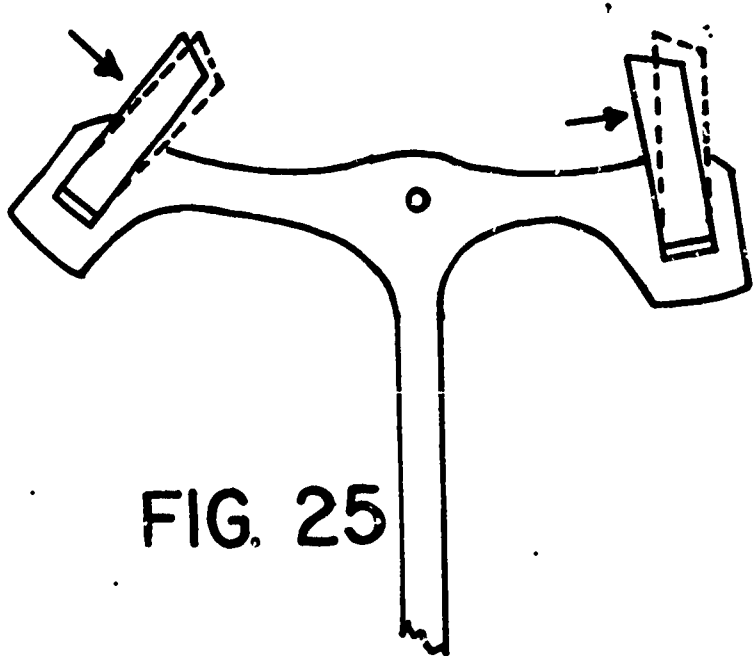

FIG. 25

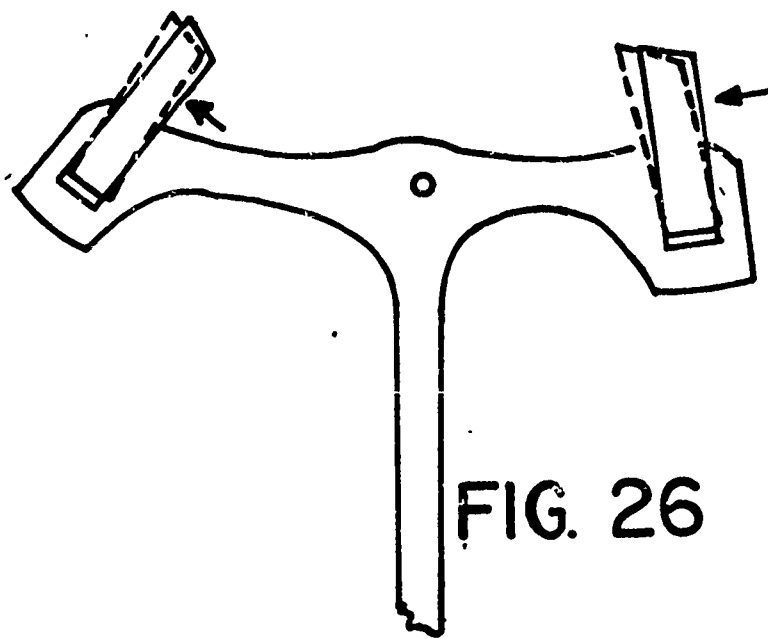

FIG. 26

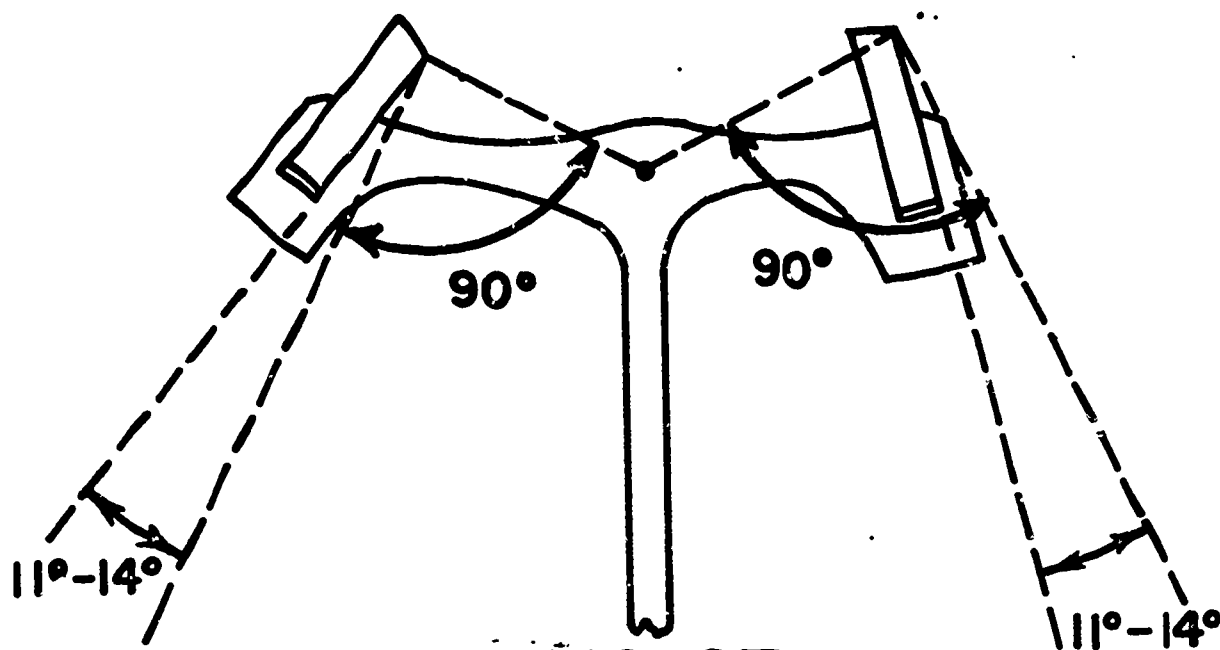

FIG. 27

Since the angle the pallet stones are set in the pallet fork determine the force of draw, it should be pointed out that if the pallet stones are tilted as shown in figure 25, the force of draw will be increased. However, if the pallet stones are tilted in the opposite direction, such as shown in figure 26, the force of draw will be reduced.

The angle of draw in watches today will vary from 11 to 14 degrees. Figure 27 shows how the angle of draw is measured on both the receiving and discharge stones.

Summary

At this point, it is sufficient that the student understand how draw occurs, the way in which the pallet stone must be inclined to result in draw, and that draw takes place after drop lock occurs.

CORNER CLEARANCE

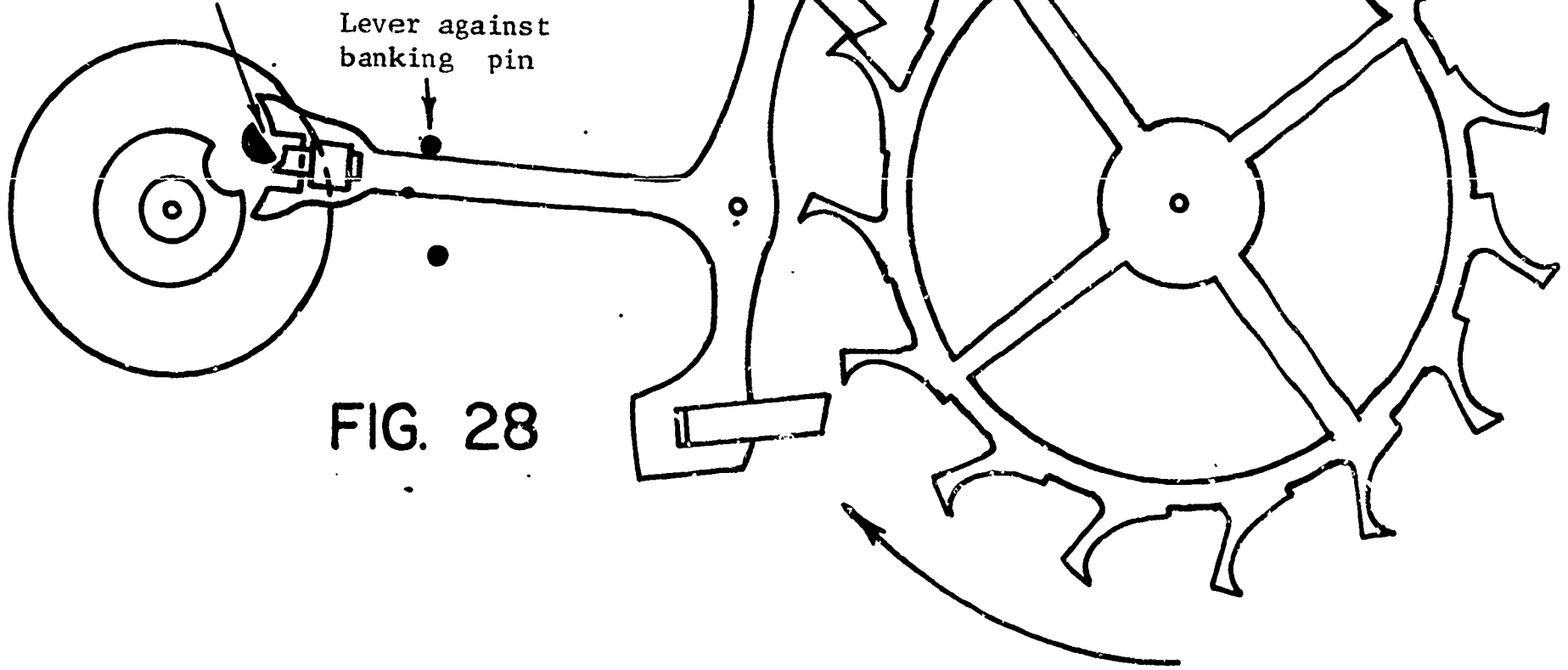

CORNER CLEARANCE

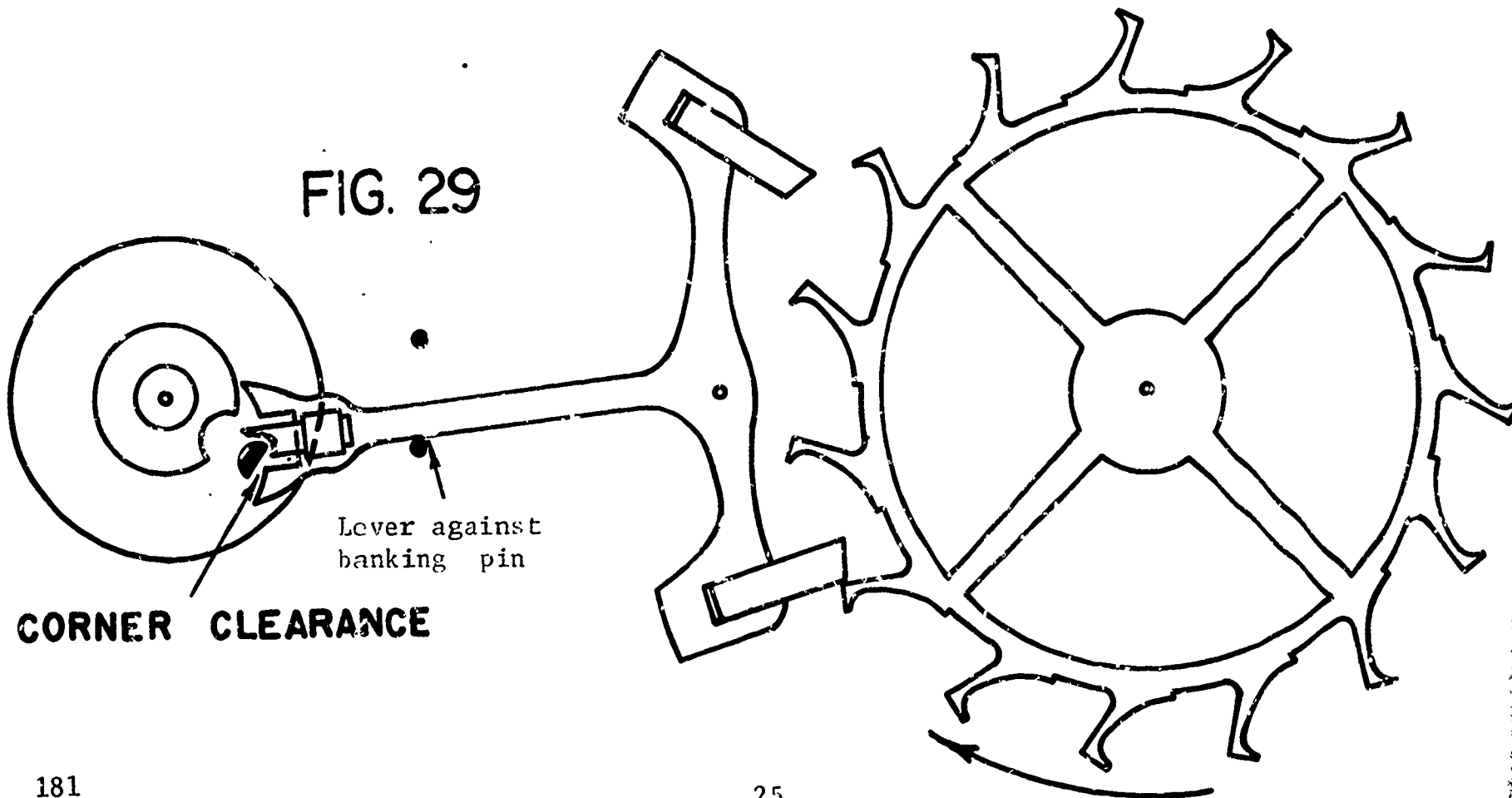

CORNER CLEARANCE

Corner clearance is shown in figures 28 and 29. Corner clearance is the space that exists between the pallet fork slot corner and the roller jewel when the pallet lever is against the banking pin. This clearance can be increased or decreased by moving the banking pins. A certain amount of corner clearance is necessary to allow the roller jewel to enter and leave the pallet fork slot without hitting or rubbing on the fork slot corner. It must be pointed out, however, that there should be no greater corner clearance than necessary. One must be aware that the greater the corner clearance, the greater will be the total lock. (See total lock figures 6 and 11). It is quite apparent that as the banking pins are moved to increase corner clearance, the total lock will likewise be increased and that the reverse is true if the banking pins are moved to decrease corner clearance.

The total lock in the escapement is a necessary evil which will be explained in full detail later. In general, the least total lock that can be set in the escapement, the better will be the time-keeping qualities of the watch.

Summary

At this point, it is sufficient for the student to understand that corner clearance is necessary, but should be no greater than needed to allow for proper freedom of the roller jewel entering and leaving the pallet fork slot. In addition, the student should understand that by moving the banking pins, the corner clearance can be altered and likewise the total lock will be affected.

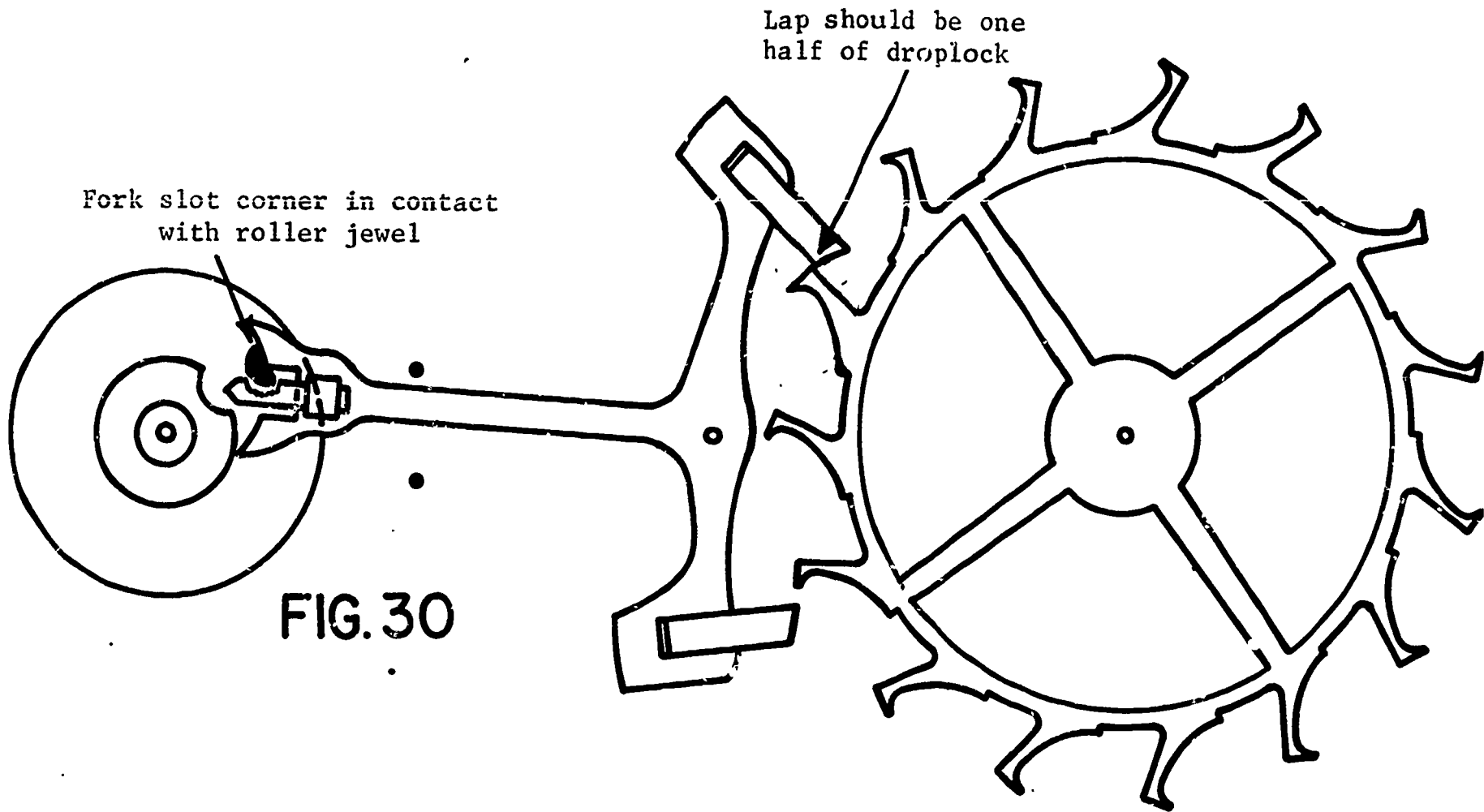

FIG. 30

CORNER TEST

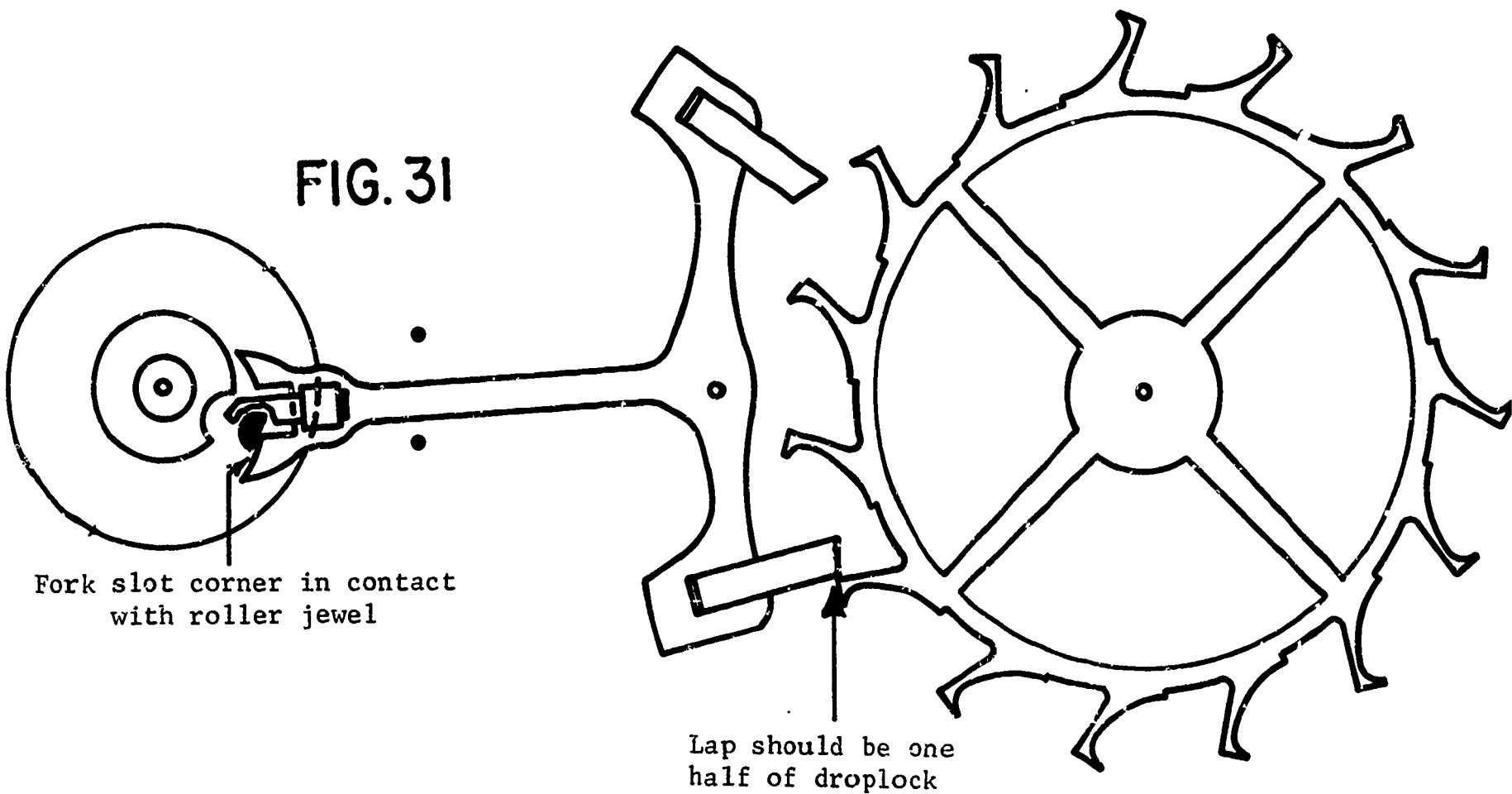

FIG. 31

Corner Test

Corner test is shown in figures 30 and 31. To make this test, the fork slot corner is brought into contact with the front face of the roller jewel. With the pallet fork held in that position, the amount of lap of the escape tooth over the locking face of the pallet stone is observed. When the escapement is correct, the lap of the escape tooth over the locking face of the pallet stone will be one-half of the lap that occurred at drop lock. Drop lock is shown in figures 5 and 10.

Corner test is taken to determine if the roller jewel is in its proper position. If the roller jewel is set too far from the center of the balance staff, then less than one half of drop lock will occur when making this corner test. On the other hand, if the roller jewel is set at a position too close to the balance staff, then over one half of drop lock will occur when making this corner test. In fact, it is entirely possible that the escape tooth could move onto the impulse face of the pallet stone. Such a condition could cause stoppage of the watch due to the roller jewel being jammed by the fork slot corner exerting a pressure against it. Such a condition is shown in figure 32.

The condition shown in figure 32 could result only through a bump or jar occurring at the instant the roller jewel is in the area illustrated. Such a bump at that time could cause the pallet fork to move away from its banking pin and if the roller jewel permits the movement of the pallet fork to such an extent that the escape tooth moves onto the impulse face of the pallet stone, such as illustrated, stoppage of the watch would most likely result.

In watches today, due to the close fit of the roller jewel, it is seldom that one would find the roller jewel in an unfavorable position, unless someone substituted an incorrect roller jewel or roller table for the original one. However, loose roller jewels or improperly set roller jewels that are out of upright can result in a condition similar to those mentioned above.

Summary

At this point, it is sufficient for the student to know that when the corner test is taken, the amount of lap of the escape tooth over the locking face of the pallet stone should be one half that of drop lock, and that this is controlled by the position of the roller jewel.

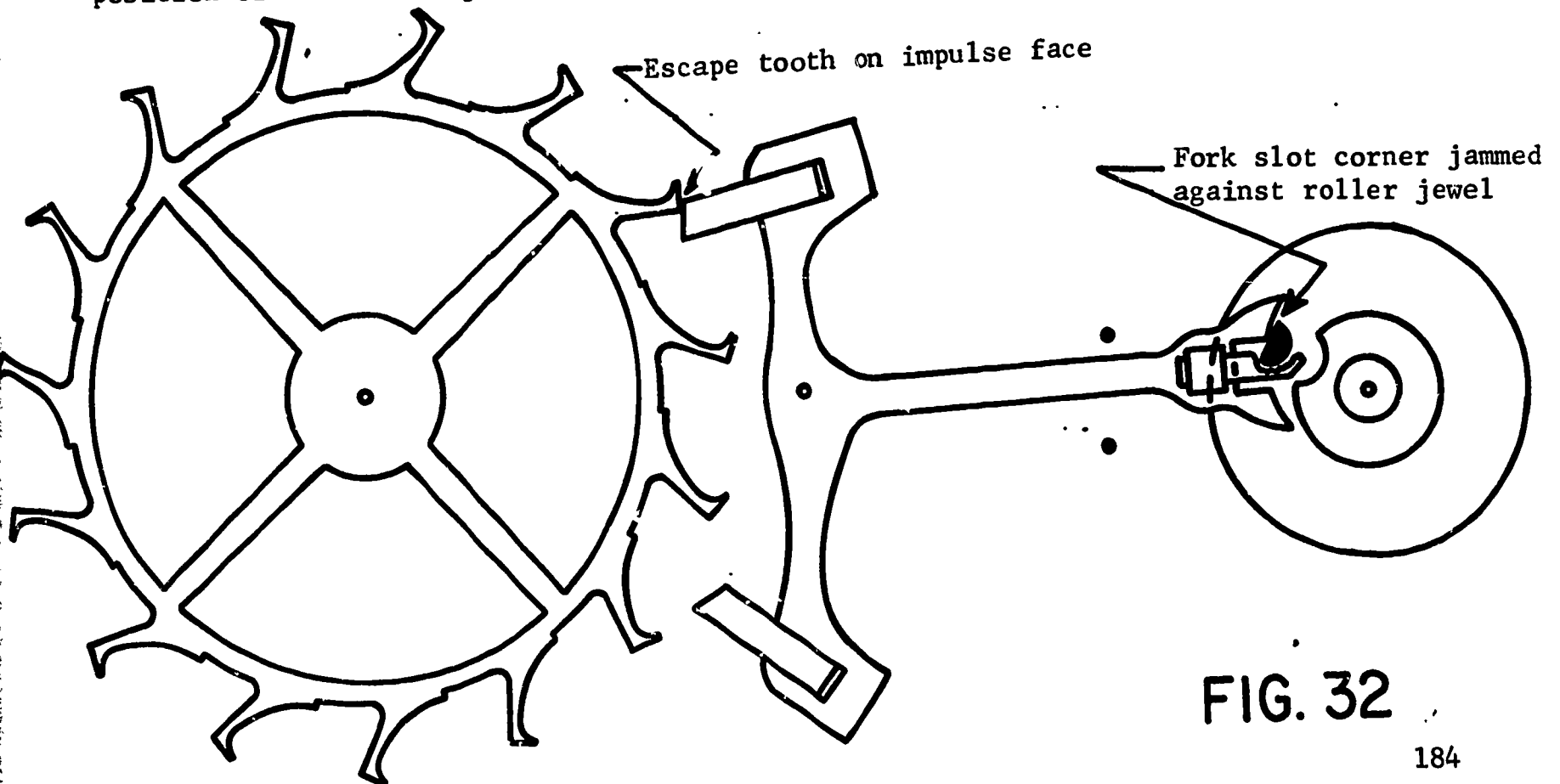
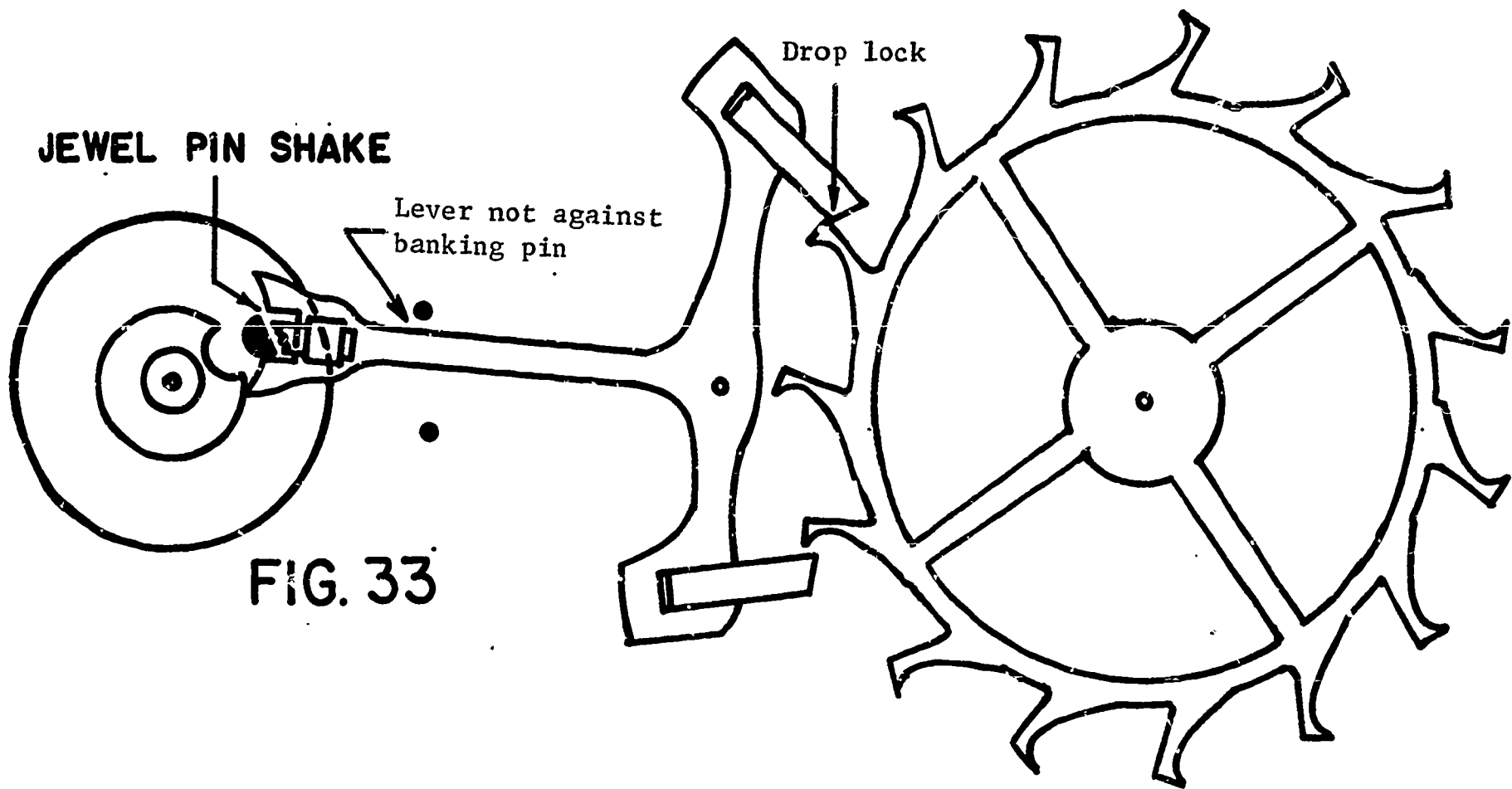
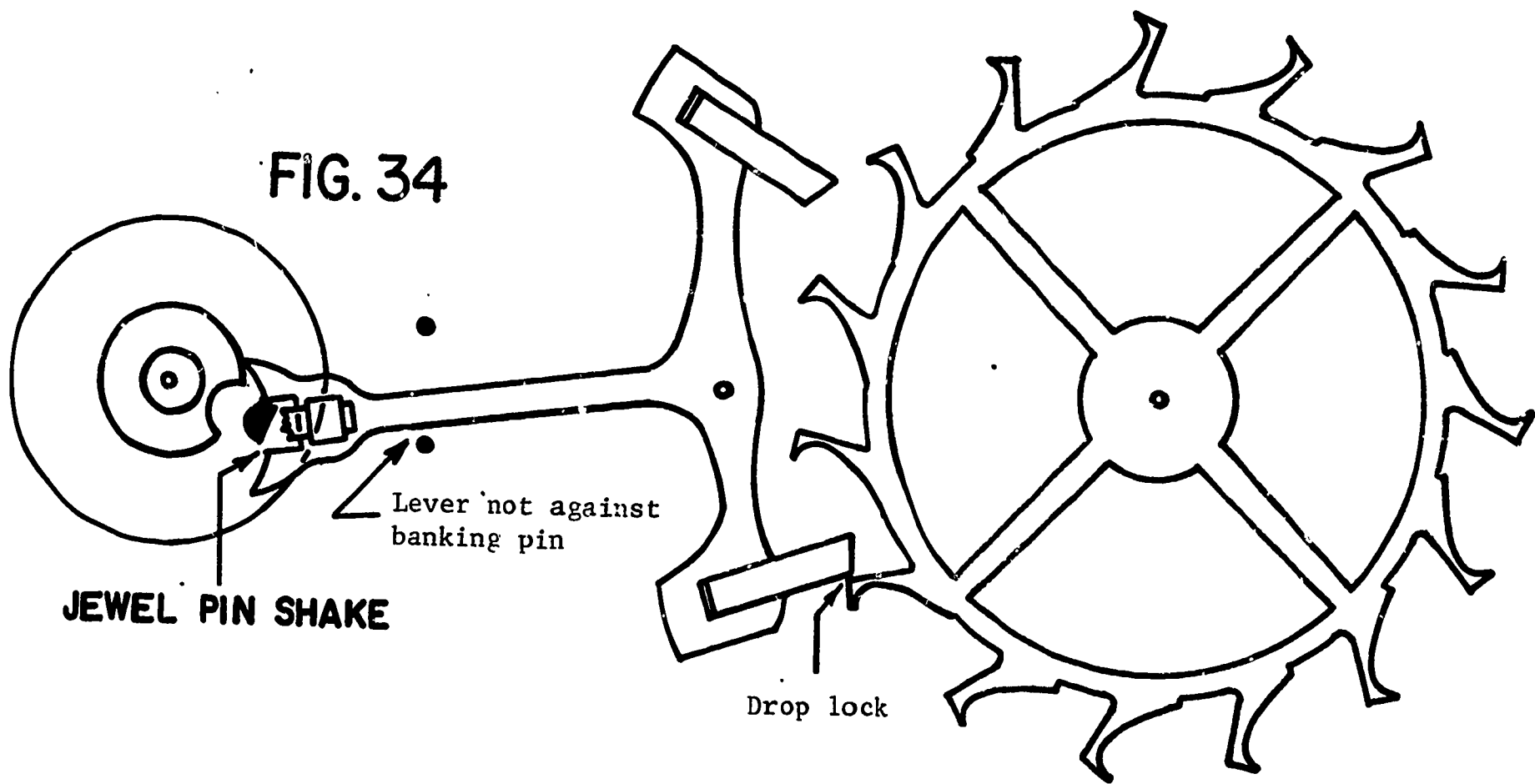

FIG. 32



JEWEL PIN SHAKE



Jewel Pin Shake

Jewel pin shake is a test to determine if the roller jewel will clear the fork slot corner at the instant drop lock occurs (see figures 33 and 34). (Jewel pin shake receives its name from the method that is used to observe this occurrence in the watch. Full information in this regard is given in section II of this book.)

It is most important that at the instant drop lock occurs, there is sufficient clearance between the roller jewel and the corner of the fork slot. This allows the roller jewel complete freedom to leave the fork slot without further contact with the pallet fork.

The amount of jewel pin shake can be altered by increasing or decreasing drop lock. Also it might be pointed out that jewel pin shake will be of the same amount on the receiving and discharge side of the escapement, if the pallet stones are matched.

Summary

At this point, it is sufficient for the student to understand how jewel pin shake is observed and that some jewel pin shake is necessary for the proper functioning of the escapement. In addition, the student should understand that the amount of drop lock has a direct relationship to the amount of jewel pin shake.

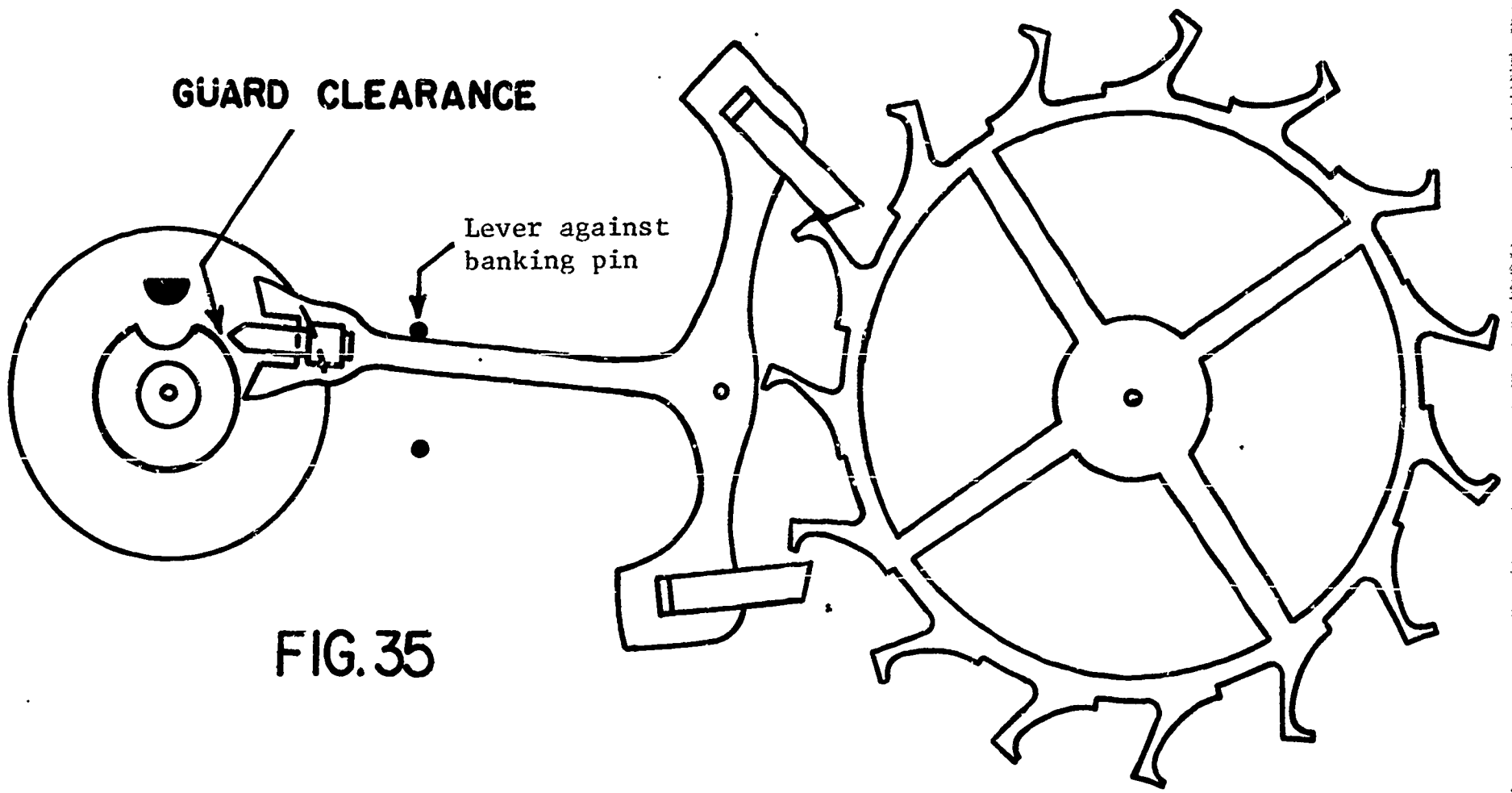

FIG. 35

GUARD CLEARANCE

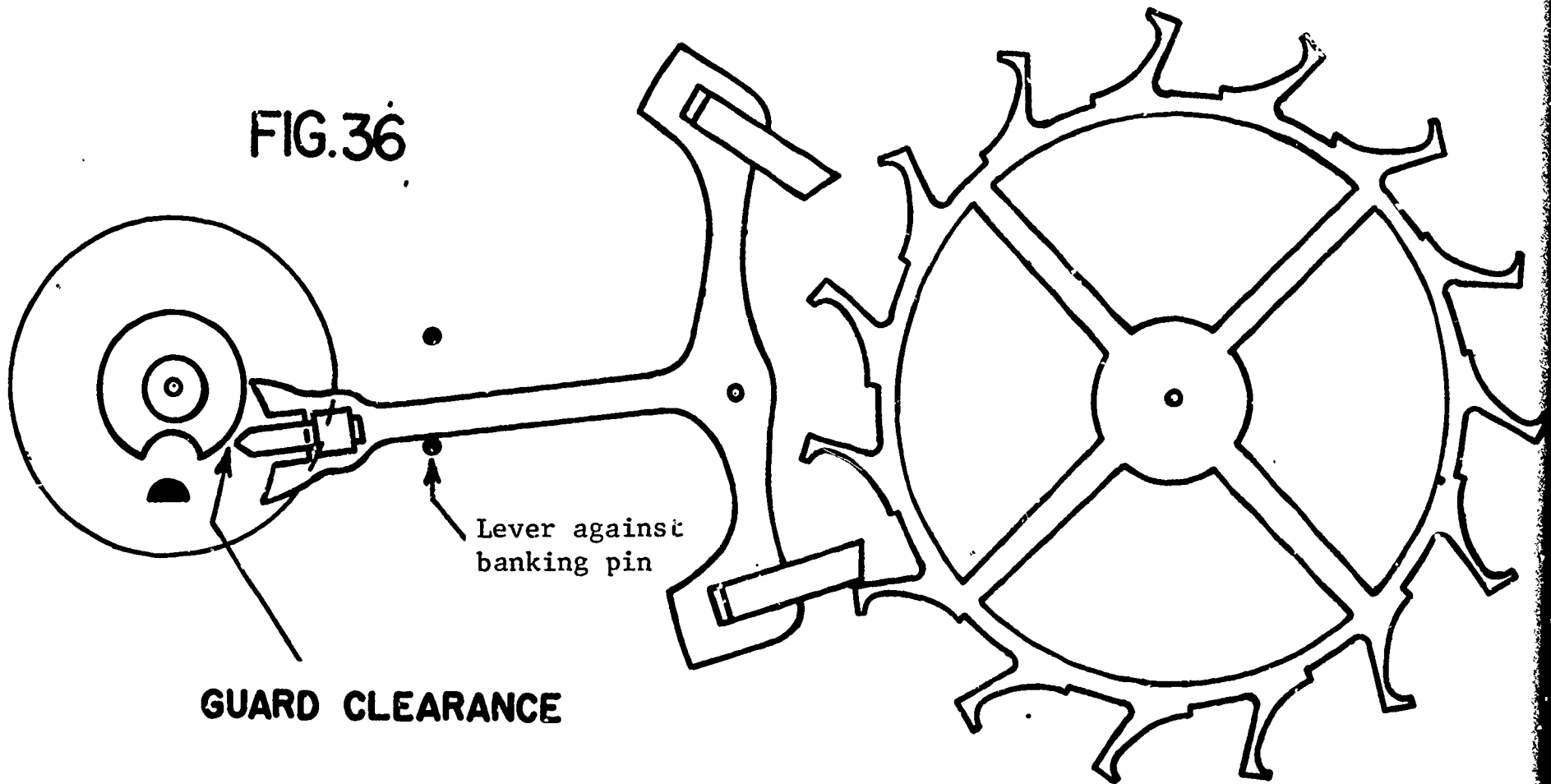

FIG. 36

GUARD CLEARANCE

Guard Clearance

Guard clearance is shown in figures 35 and 36. Guard clearance is the space that exists between the guard pin and the safety roller when the lever is against the banking pin. This clearance can be increased or decreased by either shortening or lengthening the guard pin or by moving the banking pins.

A certain amount of guard clearance is necessary to allow for the roller to turn freely without the guard pin rubbing it. However, before any adjustment should be made in reference to increasing or decreasing guard clearance, a special test should be made to determine if the guard pin is of proper length. This test, which is known as the guard test, is explained and illustrated on pages 33 and 34.

Summary

At this point, it is sufficient for the student to understand the following:

1. That there must be sufficient clearance between the guard pin and the safety roller to allow for complete freedom of the safety roller to turn.
2. That the length of the guard pin and the position of the banking pins govern the amount of guard clearance.
3. That the proper length of the guard pin can be determined by making a guard test which is explained in the following.

FIG.37

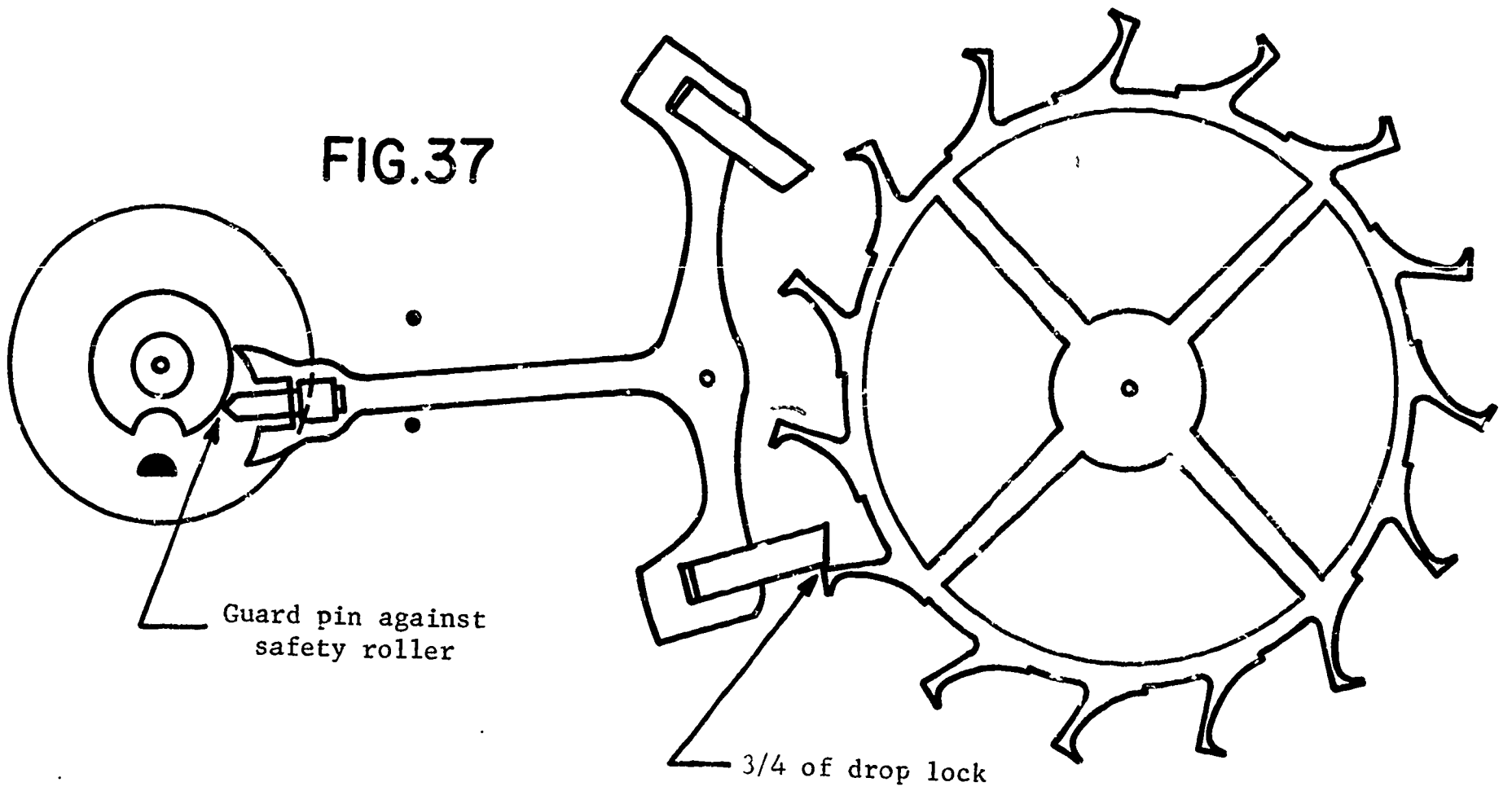

GUARD TEST

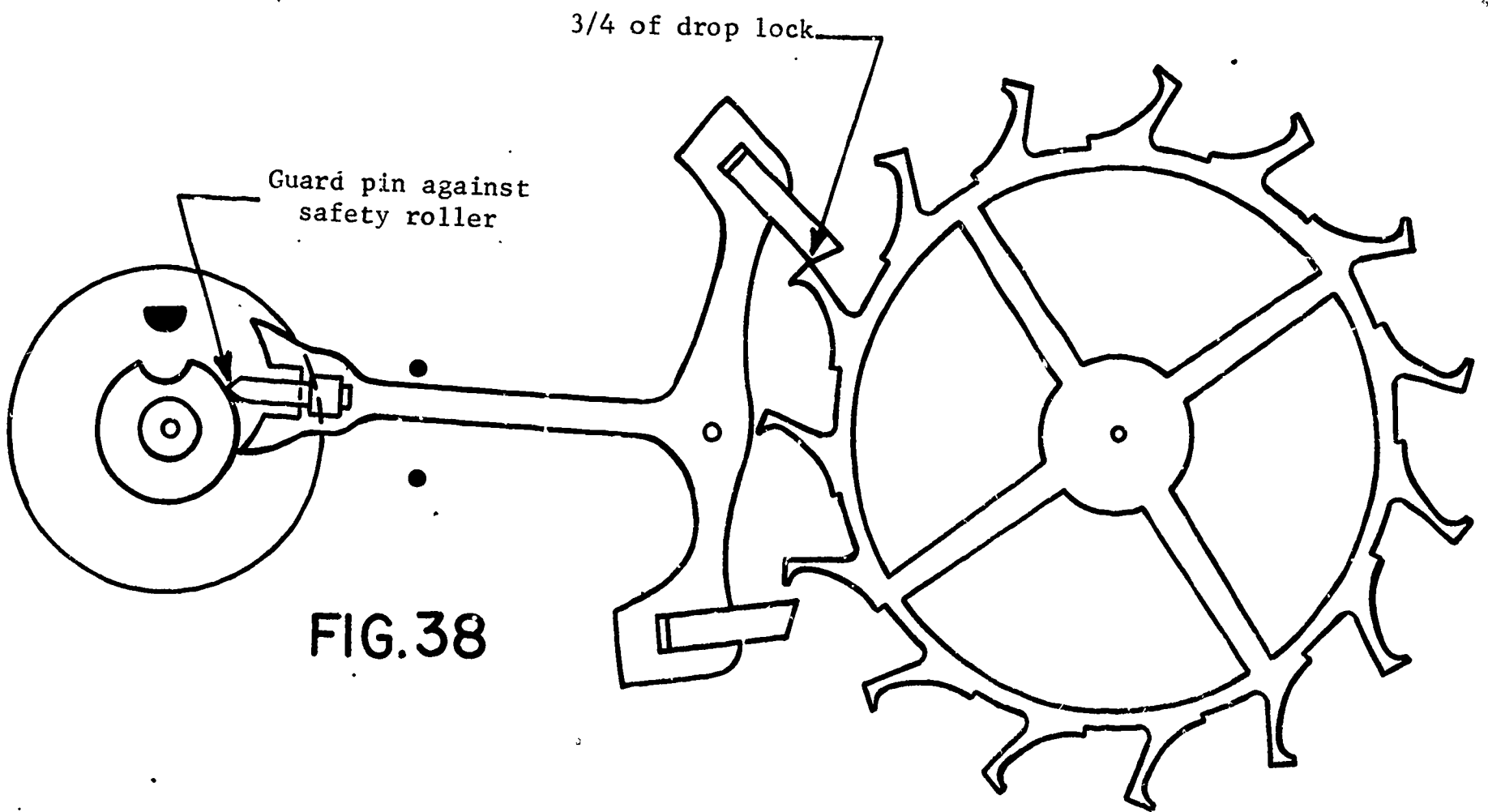

Guard Test

The guard test is shown in figures 37 and 38. To make this test, the guard pin is brought into contact with the safety roller, as illustrated. With the pallet fork held in that position, the amount of lap of the escape tooth over the locking face of the pallet stone should be observed.

When the guard pin is of proper length, the lap of the escape tooth over the locking face of the pallet stone will be $\frac{3}{4}$ of the amount of lap that occurs at drop lock (see drop lock, figures 5 and 10).

If the guard pin is too long, then the lap of the escape tooth over the locking face of the pallet stone will be greater than $\frac{3}{4}$ of the amount of lap that occurs at drop lock. On the other hand, if the guard pin is too short, then the lap may be less than $\frac{3}{4}$ of the drop lock.

If the guard test does not show to be exactly the same on the receiving and discharge side as shown in figures 37 and 38, then this would indicate that the guard pin is not straight.

Summary

At this point it is sufficient for the student to understand the following:

1. That the guard test is a test used to determine if the guard pin is of proper length.
2. That when the guard test is taken, the amount of lap of the escape tooth over the locking face of the pallet stone should be $\frac{3}{4}$ of that which occurs at drop lock.

HANG - UP

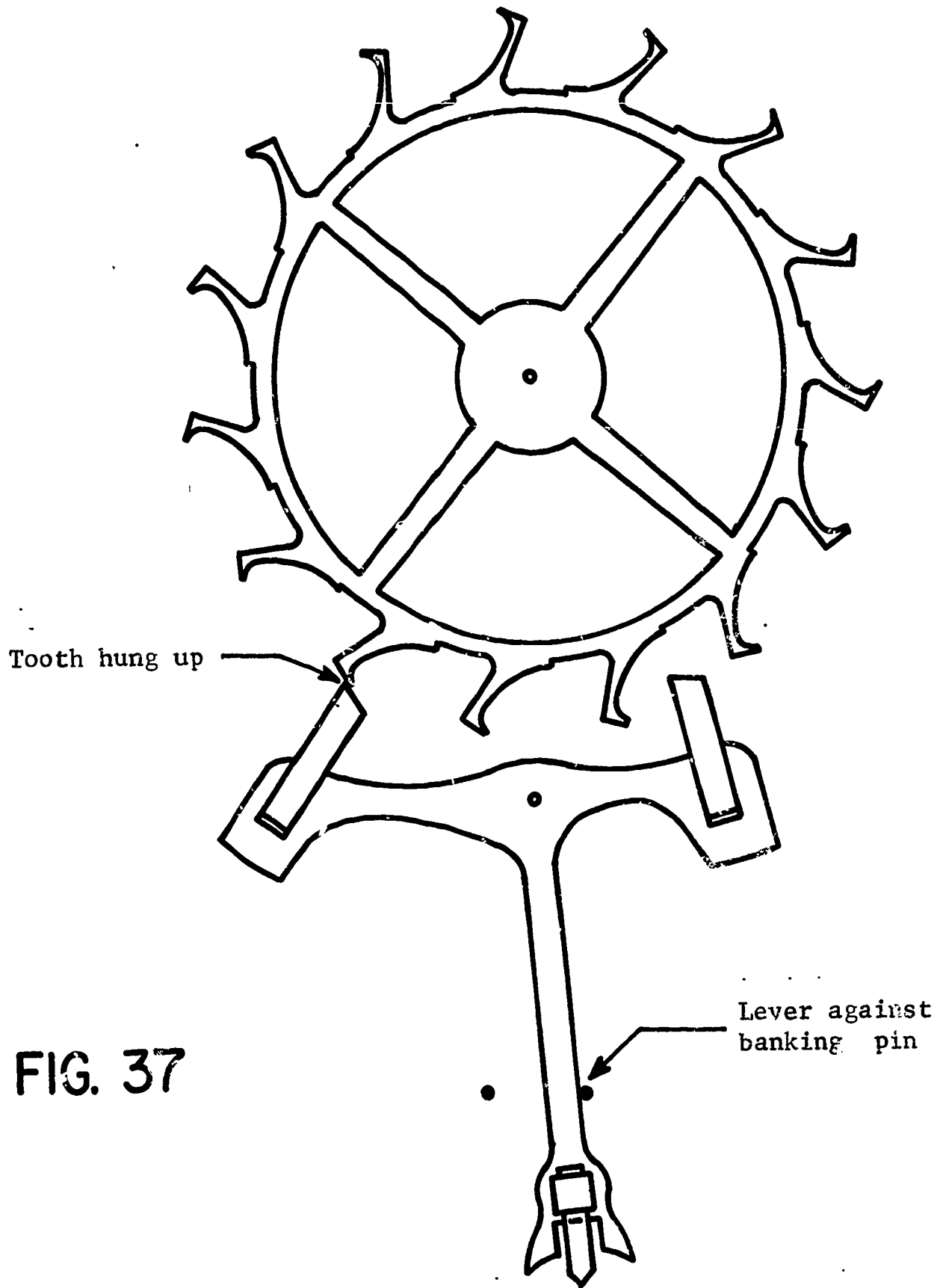

FIG. 37

HANG UP

Figure 37 shows the hang up on the discharge side. A hang up is evident when the lever is against the banking pin, but the escape tooth cannot drop off the impulse face of the pallet stone. This, of course, will cause stoppage of the watch. There are two possible corrections that can be made to eliminate a hang up: (1) the banking pin can be moved to allow the lever to move a greater distance before contacting the banking pin, and (2) the pallet stone could be moved deeper into its slot.

If drop lock shows to be $1/6$ the width of the pallet stone and the pallet stones are matched, then the hang up should be eliminated by moving the banking pins to give more angular movement to the lever. If a hang up occurs on the discharge stone, but does not also occur on the receiving stone, this indicates that the pallet stones are not matched or the banking pins are not set equally from the imaginary center line in the escapement. If the hang up occurs on one particular tooth on the escapement wheel, it must be attributed to a bad tooth. At this point, it is quite evident why a certain amount of slide in the escapement is necessary to prevent a hang up from occurring. (Pages 7 and 11 explain the function of slide).

Test Covering the Materials in Section 1 of this Book

1. Adjusting the pallet stones so that they penetrate equally into the periphery of the escape wheel when the pallet fork is centered on the imaginary center line is termed _____.
2. To adjust the depth of penetration of the pallet stones into the periphery of the escape wheel _____ is checked.
3. To determine if the pallet stones have the proper amount of separation between one another _____ are checked.
4. The pressure of the escape tooth on the locking face of the pallet stone and the angle the pallet stone is set in the slot of the pallet fork determines the force of _____.
5. The space between the guard pin and the safety roller when the fork is against its banking pin is called _____.
6. Checking the amount of lock when the pallet fork is moved to bring the guard pin into contact with the safety roller is termed _____.
b) How much lock should be present when this check is made? _____
7. _____ is the space between the roller jewel and the corner of the fork slot when the pallet fork is against its banking pin.
8. a) Checking the amount of lock when the corner of the fork slot is brought into contact with the face of the roller jewel is termed _____.
b) How much lock should be present when this check is made? _____
9. What is the proper amount of drop lock that should be set in the escapement?
_____.
10. Total lock in the escapement consists of drop lock plus _____.
11. What test is made to determine the space that exists between the face of the roller jewel and the fork slot corner at the instant drop lock takes place?
_____.
12. What test is taken to determine the proper length of the guard pin? _____
13. What test is taken to determine the proper position of the roller jewel in relation to the center of the staff? _____

14. If the receiving stone is moved outwards so that it will penetrate deeper into the periphery of the escape wheel, which of the following will occur? Check the two correct answers.

1. Drop lock will be increased on the receiving stone
2. Corner clearance will be increased
3. Drop lock will be increased on the discharge stone
4. Drop lock will increase on both stones
5. Jewel pin shake will be increased on the discharge side of the escapement
6. Jewel pin shake will be increased on the receiving side of the escapement
7. Jewel pin shake will be increased on the receiving and discharge side of the escapement

15. What two things control the amount of guard clearance? 1) _____
2) _____

16. What part of the escapement can be adjusted to increase or decrease corner clearance? _____

17. Why is slide necessary? _____

18. What is the term used when referring to a condition where the pallet lever is against the banking pin but the escape tooth cannot drop off the pallet stone?

19. The purpose of the escapement is to change the _____ motion of the train into the _____ motion of the balance.

20. How much corner clearance should be set in the escapement? _____

APPENDIX C

SIXTEEN POINT CHECKING SYSTEM AND WORK SHEET

THE 16 POINT CHECKING SYSTEM

This checking system is designed to give a continuous flow of instructions through the entire job, eliminating any chance of the student missing any vital information in the operation of completing a first-class watch repair job. In conjunction with this checking procedure, a work report sheet is used as a control so that the student will not assemble his watch carelessly, thereby eliminating the possibility of covering up poor workmanship. You will notice that on the progress report there are numbers from one to sixteen. Each time a student completes a check, the instructor will mark the time in the numbered square provided for the particular check completed. The instructor will mark the report sheet in this fashion each time that one of the sixteen checks is made. When the student first receives the watch upon which he is to work, he should immediately fill out the work report giving the following information about the watch: 1) manufacturer's name; 2) caliber number; 3) parts damaged; 4) necessary repairs; and 5) materials ordered. Once this work sheet has been filled out, the student should have it checked by the instructor, and the instructor will make a careful examination of the watch to determine if the work sheet has been filled out correctly.

At this point, the student should then begin to disassemble the watch and continue by overhauling it by following the sixteen steps listed. For the student to get the most out of the checking system, he must first check all items himself carefully before submitting it to the instructor. In this way, the student will improve his practice of observance, and form the habit of relying on himself. By making these checks, the student will soon discover his weak points and special attention can then be given to those areas of work in which the student is having the greatest difficulty.

16 Consecutive Checks and Examinations Required to Complete a Watch Repair Job

1. Check the watch over carefully to see that broken or damaged parts are ordered immediately.
2. Check each part as it is being removed from the movement in the disassembly and complete as many repairs before the watch is cleaned as possible.
3. Check the condition of the parts after they have been removed from the cleaning machine to make sure that the cleaning operation was performed satisfactorily.
4. Check the mainspring, barrel, barrel cap and oil.
5. Check the condition of time train.
6. Place barrel in watch and check for kick-back.
7. Oil train jewels and check for proper reservoir of oil around each pivot.
8. Oil winding and setting parts and check for proper winding and setting.
9. Replace pallet fork and make necessary checks on the escapement.
10. Replace balance assembly in the watch and make the necessary checks in conjunction with the escapement.
11. Check the trueness of the hairspring, flat, round, curb pins, and perfect⁷² beat.
12. Check for regulation of mean time rate, isochronism, and positions with the use of the rate recorder.
13. Replace cannon pinion and check setting and winding mechanism.
14. Replace dial and hands and make all the necessary checks on these parts.
15. Case the movement and make the necessary checks for the proper clearance of the hands, tightness of the movement in the case, and proper snap of the case.
16. Final 24-hour test and run-down test for a period of 36 to 40 hours.

What You Must Do For Check Number 1

Check the watch and proceed as follows:

- a. Check the winding to see if the mainspring is broken.
- b. Check to see if the setting bridge or sleeve is broken by pulling the stem out and testing the proper snap of stem. A broken setting bridge is easily detected, for the watch will always jump back into winding position.
- c. The balance wheel should be oscillated to see that it is true and the balance pivots should be checked by looking through the upper jewel to see that there is not a flash on the pivot.
- d. The hairspring should be checked to see that it is not damaged.
- e. The watch should be looked over in every respect, paying particular attention to any rust spots that may appear on any part of the movement. When rust is evident around the stem or setting mechanism, it is most important to remove the dial and hands in order to check this mechanism to see if the rust is very extensive.

What You Must Do For Check Number 2

- a. Examine each part as it is being removed from the movement.
- b. Check for rust on every part.
- c. Check every pivot to see that it is not damaged or bent.
- d. Check the jewels in the watch, to see that there are no cracked jewels.
- e. Check pallet stones to see that they are not chipped or damaged.
- f. When removing barrel cap, make sure that it snaps off only after sufficient pressure has been applied to it.
- g. In the examination of each part, a close check is not made at this time as many of the parts will not be clean enough for that purpose. A much closer check will be made on the parts as each part is handled in the assembly of the watch.

What You Must Do For Check Number 3

- a. When the parts are dumped out of the basket into the assembly tray, each part should be checked over quickly with the use of a watchmaker's loupe. Special attention should be paid to the jewels, because if there is gummed oil still remaining on the jewels, the cleaning job was not done satisfactorily. It is also worthwhile at this time to examine the pivots. If the jewels are clean, and the pinion leaves are clean, it is almost certain that the cleaning operation was performed effectively.

What You Must Do For Check Number 4

- a. Examine the condition of the mainspring.
- b. Check the width, strength and length of the mainspring.
- c. If correct, replace mainspring and barrel using mainspring winder.
- d. Check the oiling of the mainspring.
- e. Check the fit of the mainspring around barrel arbor.
- f. Check the mainspring end for proper shape to catch in barrel.
- g. Check the snap of the cap on barrel and replace in same position as removed.
- h. Check the end shake and side shake of barrel arbor.
- i. Check the cleanliness of the barrel and barrel teeth.
- j. Check the oiling of the barrel arbor after the cap is on.
- k. Check the condition of the barrel teeth to see if they are bent or worn.

What You Must Do For Check Number 5

- a. Jewel holes must be cleaned with pegwood if necessary.
- b. Jewels must be checked for chips or cracks.
- c. Check the train wheel pivots for rust, polish, cuts and straightness.
- d. Check the pinions for rust, pits and polish.
- e. Check the pivots for pithing - check that clean pithwood is being used.
- f. Check plates for tarnish, fingerprints, and polish jewel settings.
- g. Assemble time train and check end shake and side shake.

- h. Check wheels for trueness and upright.
- i. Lift each wheel with tweezers to check for end shake and to see if each wheel is free enough to fall back to its original position.
- j. Spin train to see that it spins freely, in dial up, dial down and a vertical position.

What You Must Do For Check Number 6

- a. Replace barrel and barrel bridge and check the oiling of the barrel arbor - upper and lower bearing.
- b. Check oiling of crown wheel.
- c. Replace ratchet wheel.
- d. Note: do not oil remainder of movement until after kick-back is checked.
- e. Wind watch slightly to check kick-back or recoil. This check should be made in dial up and dial down positions. If the watch does not have kick-back, this indicates that the train is not as free as it should be. First, however, before checking into the train itself to determine if there is some frictional error, it would be worthwhile to examine the mainspring around the barrel arbor. Many times the loose fit of the mainspring around the arbor will prevent kick-back from occurring within the train. In such instances, the arbor is simply slipped in the mainspring instead of the train receiving the reversal torque, that normally occurs. If the barrel is found to be satisfactory, then the train should be checked to see if the trouble can be located. First, the train should be examined carefully to see if each wheel is free, and if no trouble can be found, then it is advisable to remove the train wheels from the watch and replace each wheel in the watch individually and to check the spin of each wheel. If each wheel spins freely, this indicates that the pivots and the jewels are in good condition and that one need not look further for defects or faults in those areas.

Next, place two wheels at a time in the watch and check the spin of the wheels. Thus, any error of improper depthing or a badly formed tooth on a wheel or pinion will be detected. It is simply a process of elimination in order to locate the particular trouble, and of course, proper corrective measures must be taken to correct an error when one is found.

What You Must Do For Check Number 7

- a. Oil all the train jewels in the watch, and at this point it is advisable to oil also the balance jewels.
- b. Check to see that there is a ring of oil around each train pivot and that the jewels are not over-oiled or under-oiled.
- c. Check the jewels that have caps to see that the globule of oil has been formed properly between the flat cap and curved hole jewel.

What You Must Do For Check Number 8

- a. Oil stem properly.
- b. Oil friction parts of setting.
- c. Oil wolf teeth of clutch wheel and winding pinion.
- d. Oil clutch wheel groove.
- e. Oil points on setting lever that contact the setting bridge or the clutch lever.
- f. Never oil dial train. Note: dial train means all wheels following center wheel staff. Consult instructor on some types of intermediate wheels connecting clutch at setting positions that require oil.

What You Must Do For Check Number 9

- a. Check condition of pallet arbor pivots.
- b. Check for chipped or loose stones, shellac or gummed oil on pallet stones.
- c. Check guard pin for straightness and proper shape.
- d. Check polish of pallet arbor, pivots and fork slot.
- e. Check end shake of pallet fork.

- f. Check height of pallet stones in conjunction with escape wheel teeth.
- g. Check matching stones.
- h. Check drop lock.
- i. Inside and outside drop.
- j. Draw.
- k. Hang-up of stones on escape wheel teeth.

What You Must Do For Check Number 10

- a. Check tightness of roller jewel in roller table - uprightness of roller jewel.
- b. Check the height of the balance wheel in conjunction with the fork bridge and the center wheel.
- c. Check the clearance of the curb pins to balance bars.
- d. Check the height of the guard pin in relation to safety roller.
- e. Check the proper length of roller jewel and fit of roller jewel to fork slot.
- f. Check the guard clearance.
- g. Check the corner clearance.
- h. Check the jewel pin shake.
- i. Check the guard test.
- j. Check the corner test.

What You Must Do For Check Number 11

- a. Check the hairspring in-the-flat.
- b. Check the hairspring in-the-round.
- c. Check the quadrant of the hairspring to see that it is formed properly between the curb pins.
- d. Check the perfect beat of the watch by equalizing the force to receiving and discharge pallets.
- e. Check for the collet wobble.
- f. Check for trueness of the balance wheel, and for the flash of the balance pivots.

g. Check for trueness of roller table.

What You Must Do For Check Number 12

- a. Place the watch on the timing machine and take a rate in the dial down position, then turn the movement over to dial up position and take a rate. There are three things that should be observed from the rate that was taken:
1. Dial up should indicate the same time as dial down.
 2. Observe the closeness of the lines to determine if the watch is in perfect beat.
 3. Observe how the watch is running in reference to the time error over a 24-hour period.
- b. Adjust the mean time rate of the watch so that the dial up and dial down positions will record on time. Do not move the regulator more than one degree in adjusting the mean time rate. Any other alteration must be made by adjusting the curb pins or by adding or removing weight from the balance wheel.
- c. If the rates in dial up and dial down are found to be different from one another, then this indicates a mechanical error in the watch which must be traced out before proceeding.
- d. If the watch is found to be out-of-beat, then of course, it should be put in proper beat at this time. We might emphasize that if the watch was put in proper beat in accordance with the proper procedure at the bench, then an out-of-beat condition would not be indicated on the timing machine.
- e. When the above conditions have been satisfied, the next step would be to take a rate in a pendant down and pendant up position. At this point, all the printed ratings should be turned over to the instructor so that he may examine the watch and observe the rates at the same time. If everything has proved to be satisfactory, the instructor will then request that an isochronal test be made on the timing machine, which consists of leaving

the ratchet wheel down three revolutions and taking a rate in the dial up position.

What You Must Do For Check Number 13

- a. Check for proper lubrication of cannon pinion on center post.
- b. When replacing the cannon pinion, be sure that the leaves of the cannon pinion do not come down on top of the minute wheel teeth so as to bend the teeth of the minute wheel.
- c. Check tightness of cannon pinion.
- d. Check to see that cannon pinion does not ride up when watch is being set.

What You Must Do For Check Number 14

- a. Make sure that the hands are fitted securely to the parts to which they are attached.
- b. Make sure that the hands are adjusted so that there is equal space between the hands and the hands are set as close to the dial as possible.
- c. Check to be sure that the hands are shaped to the contour of the dial.
- d. Check to see that the hands are positioned so that they are synchronized with one another.

What You Must Do For Check Number 15

- a. If there is no case for the movement, simply disregard this check and proceed with the next check, number 16.
- b. Check for proper snap of the case.
- c. Check for the clearance of the hands under the crystal.
- d. Check the crystal to see that it is securely fitted into the case.
- e. Check to see that the crown is next to the stem and reasonably close to the case.
- f. Check for tightness of movement in case.
- g. Check the spring bars to see that proper spring bars are used for the particular type of case so that the band is held securely to the case.
- h. Check the lug holes to see that they have not been worn badly by the spring

bars to a point where the hole may break through and allow the spring bar to come out of place.

What You Must Do For Check Number 16

- a. Set the watch on time with a master clock.
- b. Let the watch run for a period of 24 hours and check the error in the time.
- c. Allow the watch to run until it completely runs down and check the length of run. The watch should run a minimum of 36 hours, preferably 40 hours, if it is in "A 1" condition.

GRADING OF WATCHES

Listed below is the Grading System that will be used on all practice watches. A total of 70 points or more must be obtained on each watch in order for a student to pass.

| | | |
|---|-----|-------|
| Function of winding ----- | 3% | _____ |
| Function of setting ----- | 3% | _____ |
| Centering, clearance and fit of hands ----- | 5% | _____ |
| Cannon pinion tightness ----- | 4% | _____ |
| Dial Adjustment ----- | 4% | _____ |
| Condition of all steel work and jewel settings ----- | 4% | _____ |
| Condition of cleaning ----- | 10% | _____ |
| Condition of oil ----- | 8% | _____ |
| Condition of regulator pins ----- | 2% | _____ |
| Quadrant curve in conjunction with curb pins | 5% | _____ |
| Flatness and trueness at the collet ----- | 5% | _____ |
| Hairspring adjusted in-the-round ----- | 6% | _____ |
| Hairspring adjusted in-the-flat ----- | 6% | _____ |
| Trueness of balance wheel ----- | 7% | _____ |
| Endshake of balance staff ----- | 4% | _____ |
| Sideshake of balance staff ----- | 4% | _____ |
| Condition of balance pivots ----- | 5% | _____ |
| Condition of drop lock, inside and outside drop ----- | 4% | _____ |
| Condition of draw ----- | 3% | _____ |
| Corner and guard test and guard clearance -- | 5% | _____ |
| Freedom of train ----- | 3% | _____ |

TOTAL 100%

SAMPLE WORK REPORT

Student Name: _____ Date: _____ Time: _____

| Manufac- turer's Name | Caliber No. | Parts Damaged | Necessary Repairs | Materials Ordered |
|-----------------------------|-------------|---------------|----------------------|----------------------|
| | | | | |

| | | | | | | | |
|-------|----|----|----|----|----|----|----|
| 1 | 2 | 3 | 4 | 5 | 6 | 7 | 8 |
| Time: | | | | | | | |
| 9 | 10 | 11 | 12 | 13 | 14 | 15 | 16 |
| Time: | | | | | | | |

Comments: _____

Grade: _____

Estimate of repairs can be written on the back of this sheet.

APPENDIX D

INCLINE GRAVITY CLOCK - JETS PROJECT

INCLINE GRAVITY CLOCK

**A PROJECT DESIGNED ESPECIALLY FOR THE
JUNIOR ENGINEERING TECHNICAL SOCIETY**

By

Hugh G. Wales, Ph.D.

William O. Smith, Jr.

Gray Lawrence

**Watch Technician
and
Micro-Precision Technology**

**University of Illinois
Urbana, Illinois**

JETS PROJECT

Making an Incline Gravity Clock

The complete clock unit with incline plane is shown in figure 1. This clock indicates the time by the hand pointing to the linear time scale on the side of the incline plane.

Instead of the hand turning as you would expect on an ordinary clock, the drum will turn and move down the incline. The drum makes one revolution every twelve hours. The incline plane is made long enough to allow for two revolutions of the drum, which is twenty-four hours of run.

In order that the drum will stay in position on the incline plane, the clock movement inside the drum is weighted (see figures 2 and 3). The clock movement in the drum is supported by the center tube of the hour wheel being fitted securely into a center hole, drilled in a disc (figure 2).

Thus, as the clock movement runs, the movement itself will turn at the same ratio as an hour hand turns on an ordinary clock (once every twelve hours).

With this arrangement, and the drum placed on an incline plane, the movement will not turn but the drum will roll down the incline plane at the rate of one revolution every twelve hours. In order to provide this unit with a time indicator, all that is necessary is to loosely fit a hand as shown in figures 1, 2 and 3 to the drum lid, so that it is free to point to the bottom.

To make this incline gravity timepiece, proceed as follows:

1. An inexpensive alarm clock will be satisfactory for this project. If one is not available, a new suitable Westclox alarm clock movement without case can be ordered from the Gem City School of Horology, Seventh and State Streets, Quincy, Illinois, at \$1.95 each.
2. For this illustrated text, the Westclox alarm clock is used. However, if one wishes to use another make or model alarm clock, do not hesitate to do so, as only small apparent changes would most likely result.

3. Remove the clock movement from its case. Usually this is done very easily by removing the case screw, et cetera.
4. Remove all hands by pulling them up with two screwdrivers as shown in figure 4. Two pencils can be used to provide the fulcrum points, as illustrated.
5. Remove dial. Most alarm clock dials are held on by metal lips that are bent over to grip the movement. Once the lips are straightened, the dial will easily come off.
6. Now remove the alarm bridge, figure 5, by bending back the lips "B", located either side of the bridge, to unclamp it from the movement.
7. Lift off the hour wheel from the center post.
8. Remove the alarm arm "A" (figure 3) from the clock movement. If this arm is riveted, the rivet heads can be drilled off to allow removal of the arm.
9. Having removed the alarm arm, the hole "H" in the center of the arm must be enlarged by drilling, filing or reaming so that it will fit over the hour wheel tube (figure 4).
10. The hour wheel should now be placed on the center post and the alarm arm "A" placed over the hour wheel and screwed down in place. The opposite end should be bent to fit under the plates. The new purpose of this arm is to keep the hour wheel from moving out.
11. Measure outside diameter of the movement.
12. Select plastic cylinder 1 inch larger in diameter than the movement and long enough to clear each end of the protruding post of the movement.
13. Machine a plastic disc about 3/16 inch thick to fit neatly into the cylinder.
14. Drill a hole in the center of the disc so that the hour wheel tube can fit tightly into the hole (see figures 2 and 3).
15. Place the plastic disc (figures 2 and 3) into the cylinder to a position that centers the movement when it is inserted into the cylinder with the hour tube frictioned into the hole in the disc (see figures 2 and 4).

16. Make sure the disc is parallel to the lid in the cylinder and cement it in place on each side of the disc by running plastic cement around the circumference of the disc.
17. The movement must be weighted before inserting into the cylinder. By holding the center shaft on each end (figure 4), allow the heaviest part of the movement to drop to the bottom. Rarely will the movement be heavy enough at one place as desired. To increase the weight of the movement at the heaviest place, take a fishing sinker, such as illustrated, and attach it to the bottom or heaviest place of the movement (see figures 2 and 3). Mark the exact place which can be considered the bottom.
18. Insert the movement into the cylinder so that the hour wheel will enter the hole in the disc friction tight.
19. Machine a lid for each end of the cylinder about 1/4" larger in diameter than the cylinder (see figures 2 and 3) so that it will fit friction tight.
20. Drill a hole in the center of one lid for installation of the indicator hand.
21. The minute hand from the alarm clock movement can be used as an indicator. An arbor, however, would have to be made such as shown in figure 2. The arbor is inserted through the hole in the plastic disc and the hand frictioned onto the end of the arbor. It is important that the arbor turn freely in the plastic disc, so that the hand will always fall freely to the bottom by its own weight. This arbor can be made out of a small nail or tack.
22. The incline plane can be made of wood and the numbers to be used on the incline plane can be purchased at a hardware store. The angle of the incline should be such that the place which has been marked as the bottom of the movement will move to 45 degrees from the horizontal when the clock is placed on the incline. Be sure the clock is placed on the incline in the proper direction. If it is placed on the incline backwards, it will try to move up the incline which will put a drag on the

clock train and stop it. The length of the incline must be sufficient to allow for two revolutions of the drum and about 3 inches longer to give sufficient clearance for the drum on each end of the incline plane.

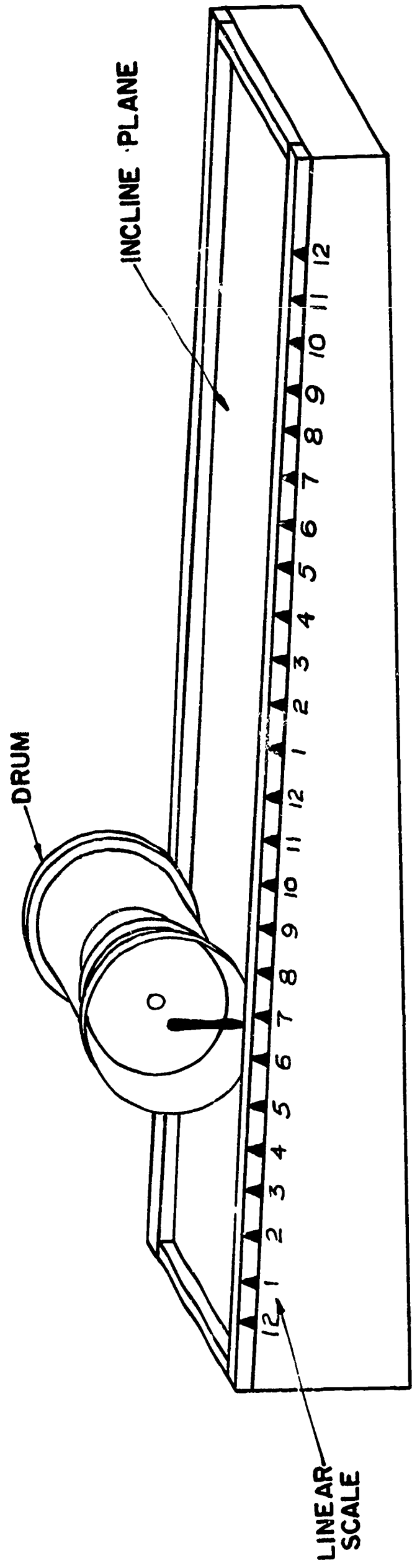

FIG. 1

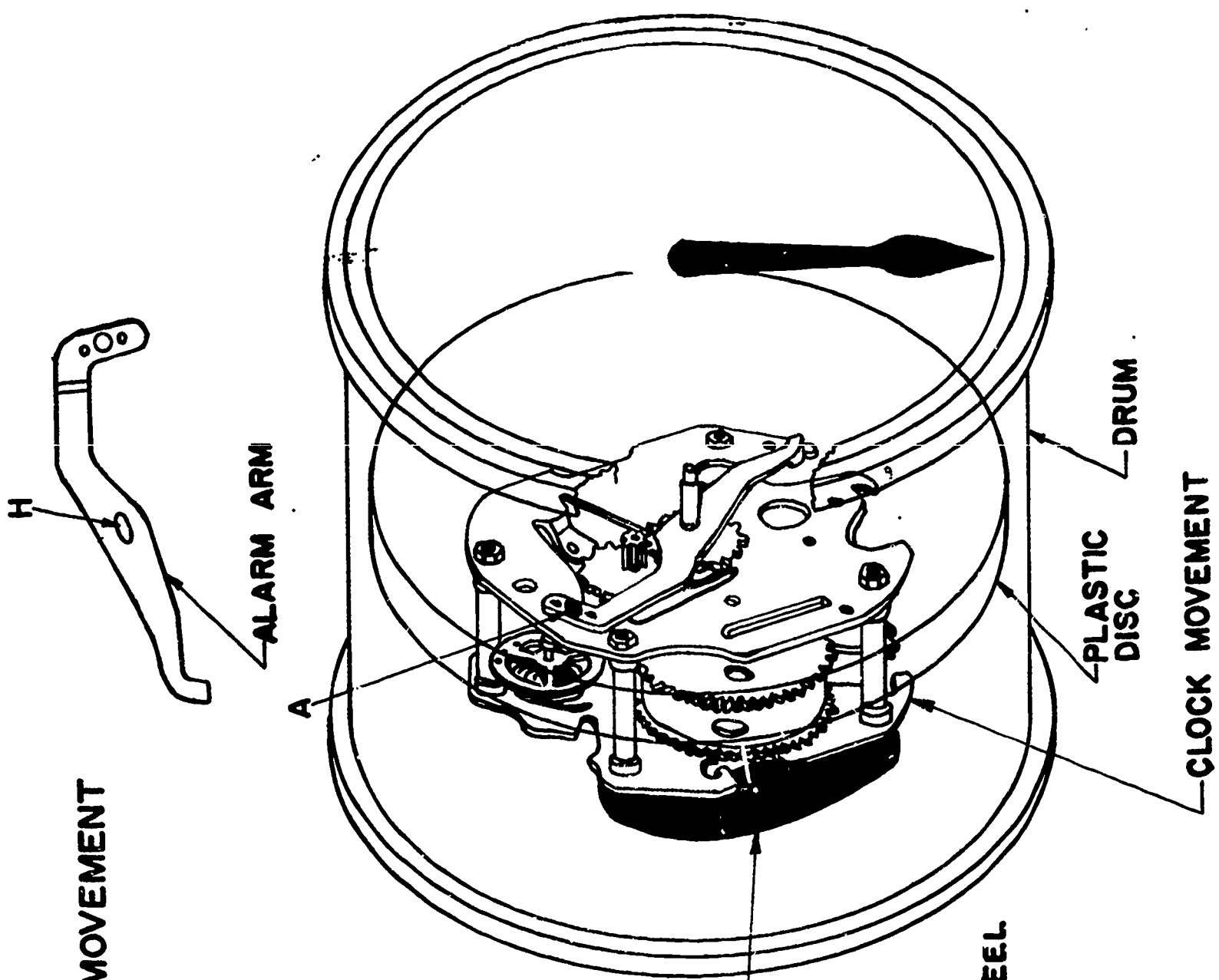

FIG. 3

CENTER LINE OF MOVEMENT

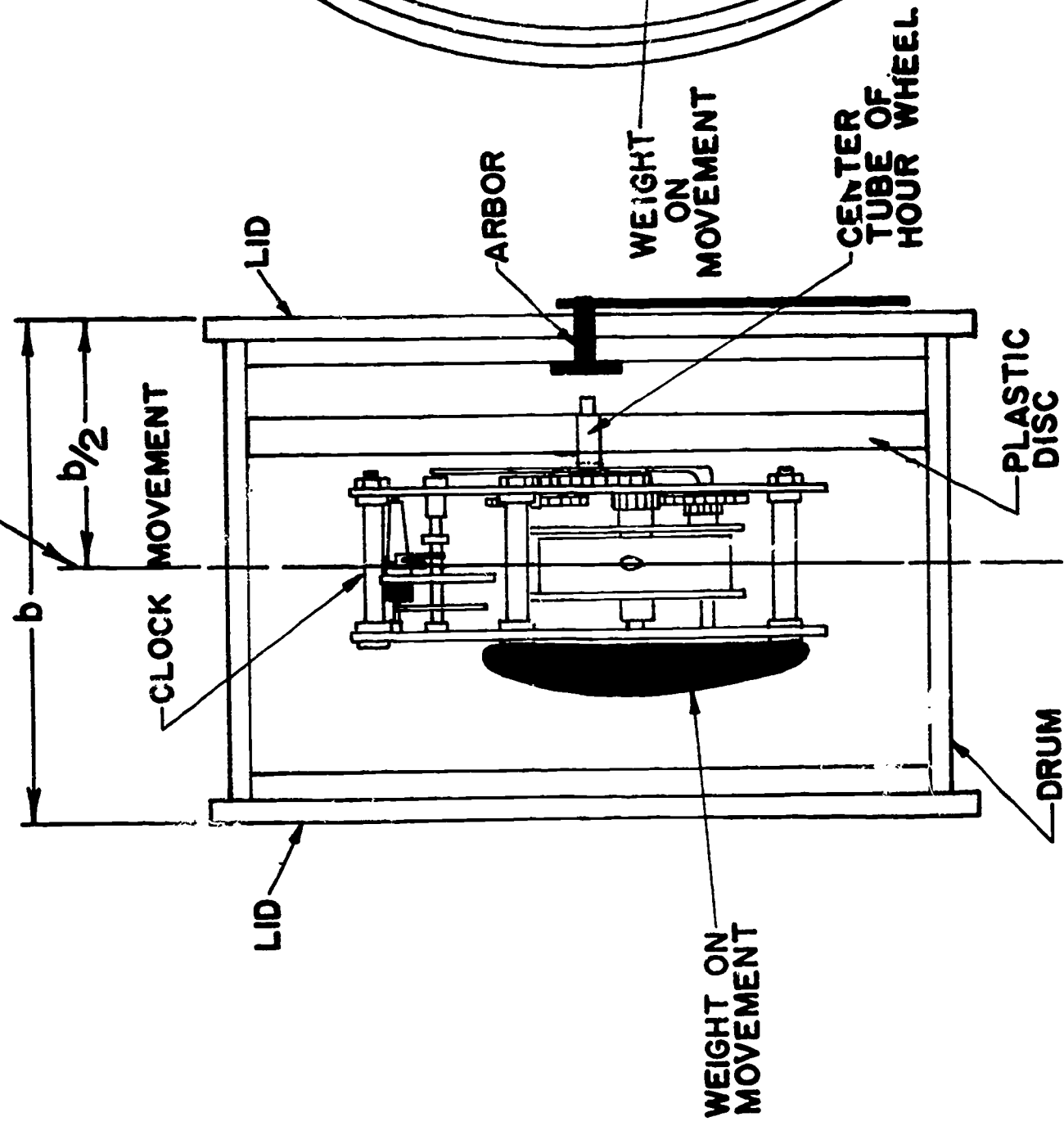

FIG. 2

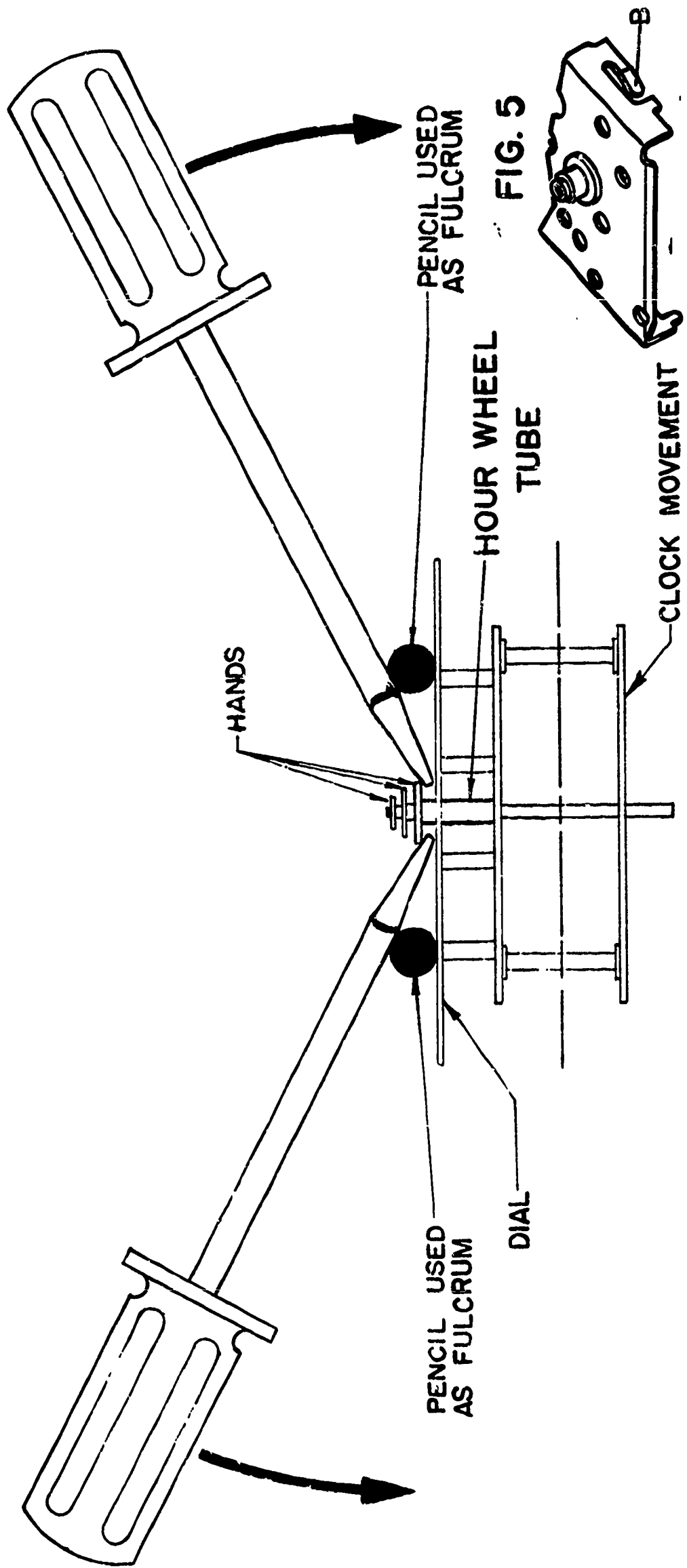
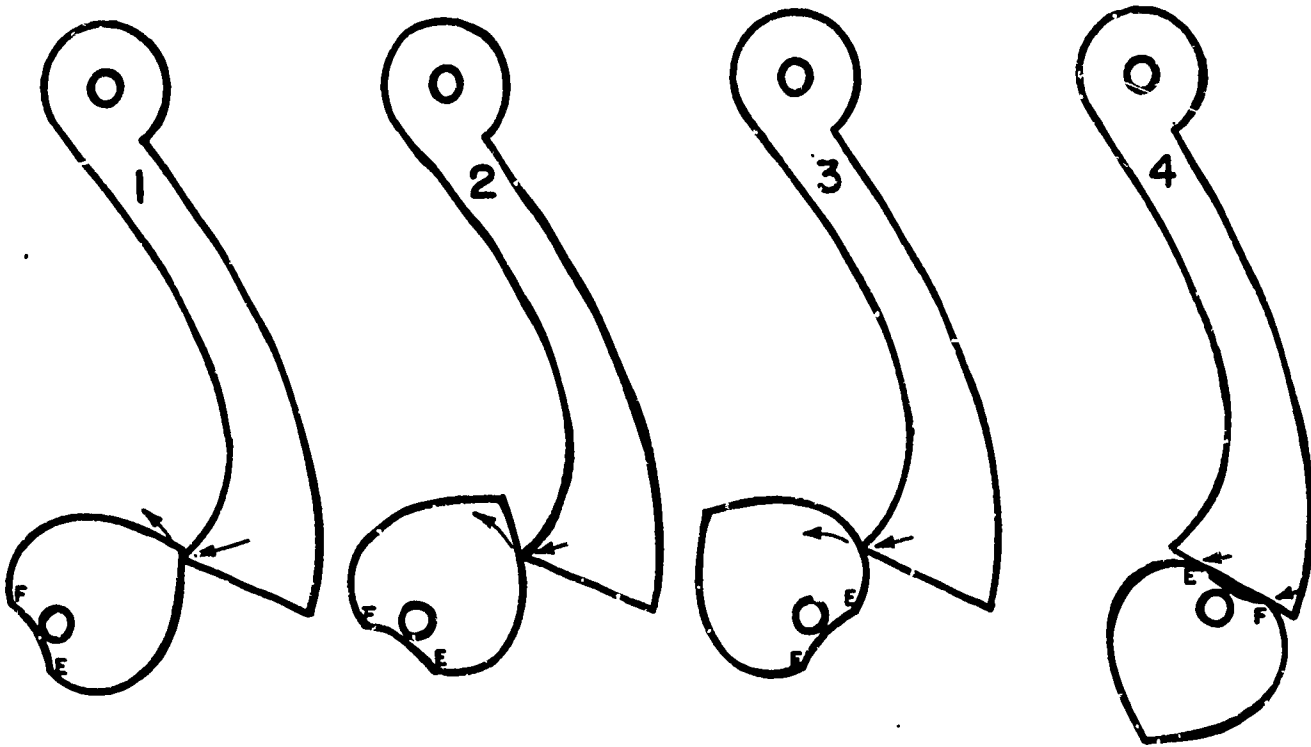
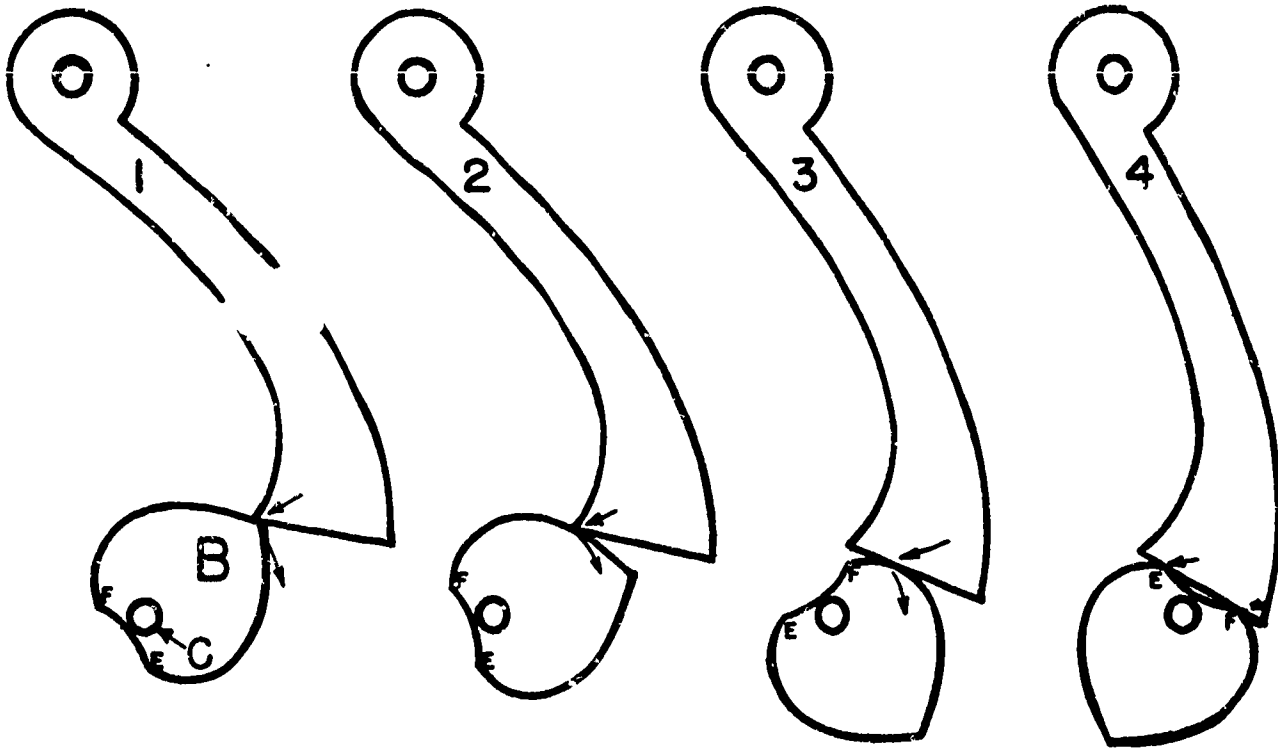

FIG. 4

APPENDIX E
CHRONOGRAPH ILLUSTRATIONS

- A - Flyback Lever
- B - Heart
- C - Staff
- D - Sweep Seconds Hand



- A - Flyback lever
- B - Flyback lever branch
- C - Flyback lever branch
- D - Minute register heart
- E - Seconds heart
- F - Minute register wheel
- G - Seconds wheel
- H - Minute register pawl
- J - Lobe of heart
- K - Lobe of heart
- L - Inclined plane of minute register pawl

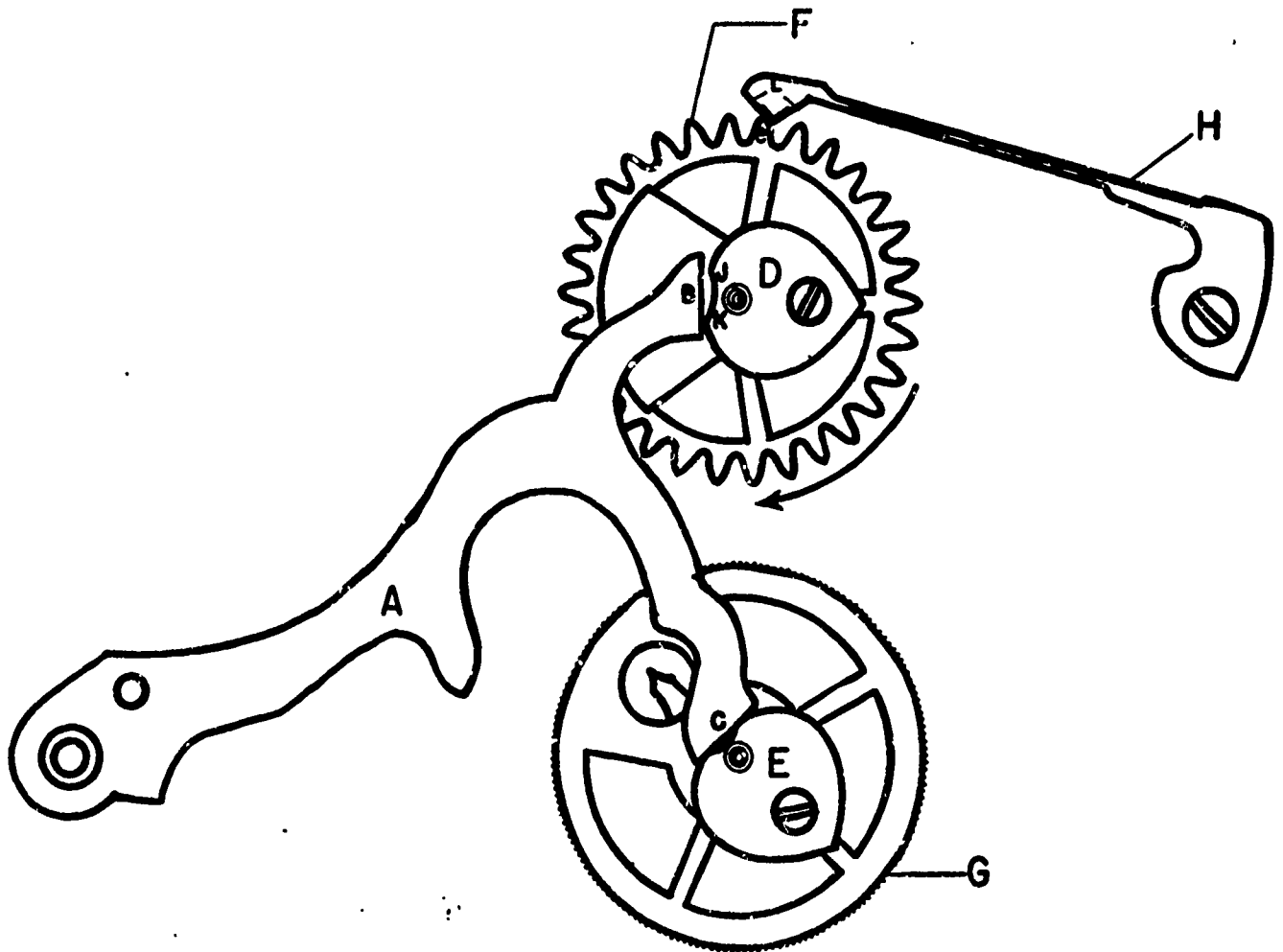
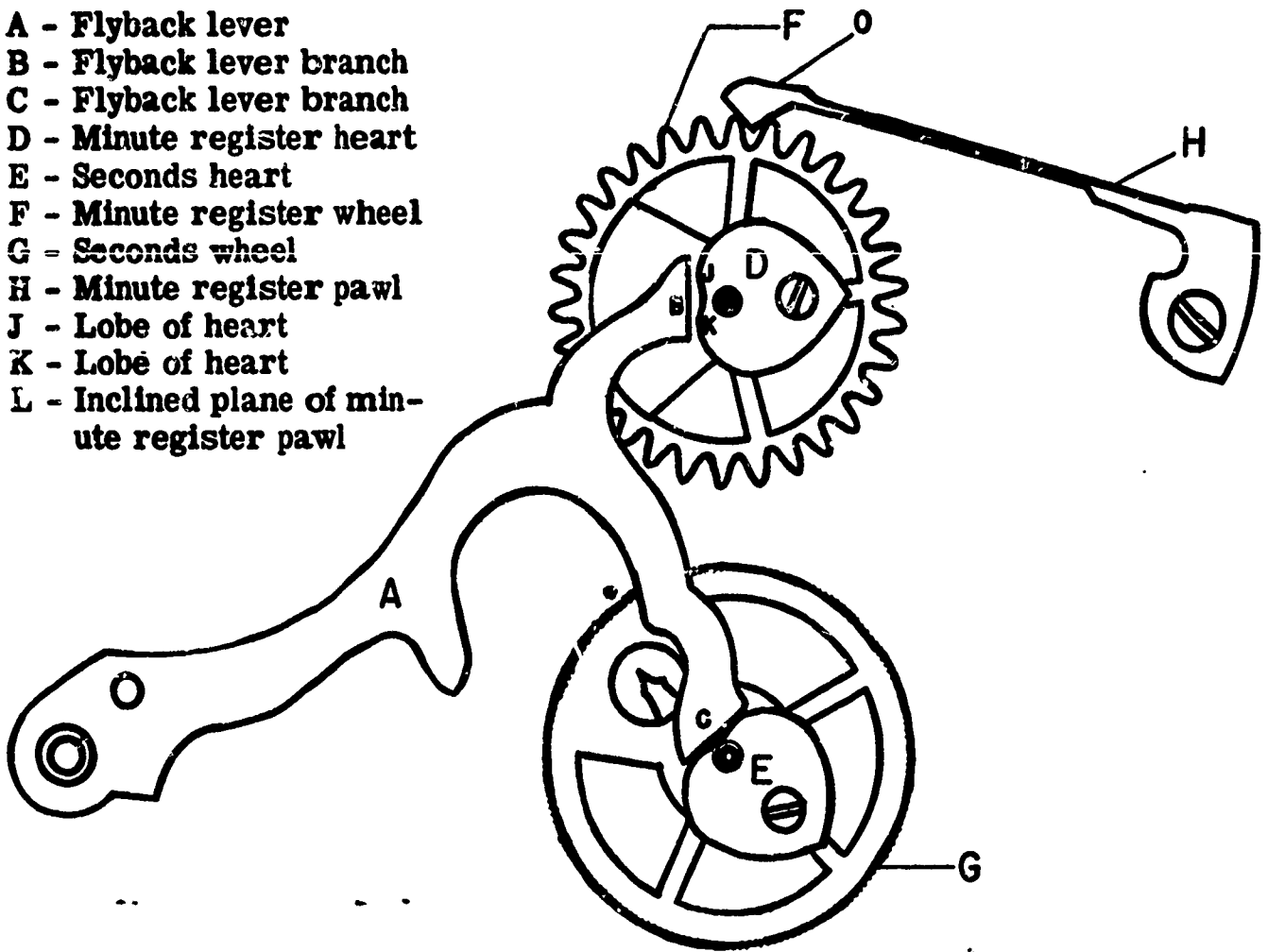

- A - Flyback lever
- B - Flyback lever branch
- C - Flyback lever branch
- D - Minute register heart
- E - Seconds heart
- F - Minute register wheel
- G - Seconds wheel
- H - Minute register pawl
- J - Lobe of heart
- K - Lobe of heart
- L - Inclined plane of minute register pawl

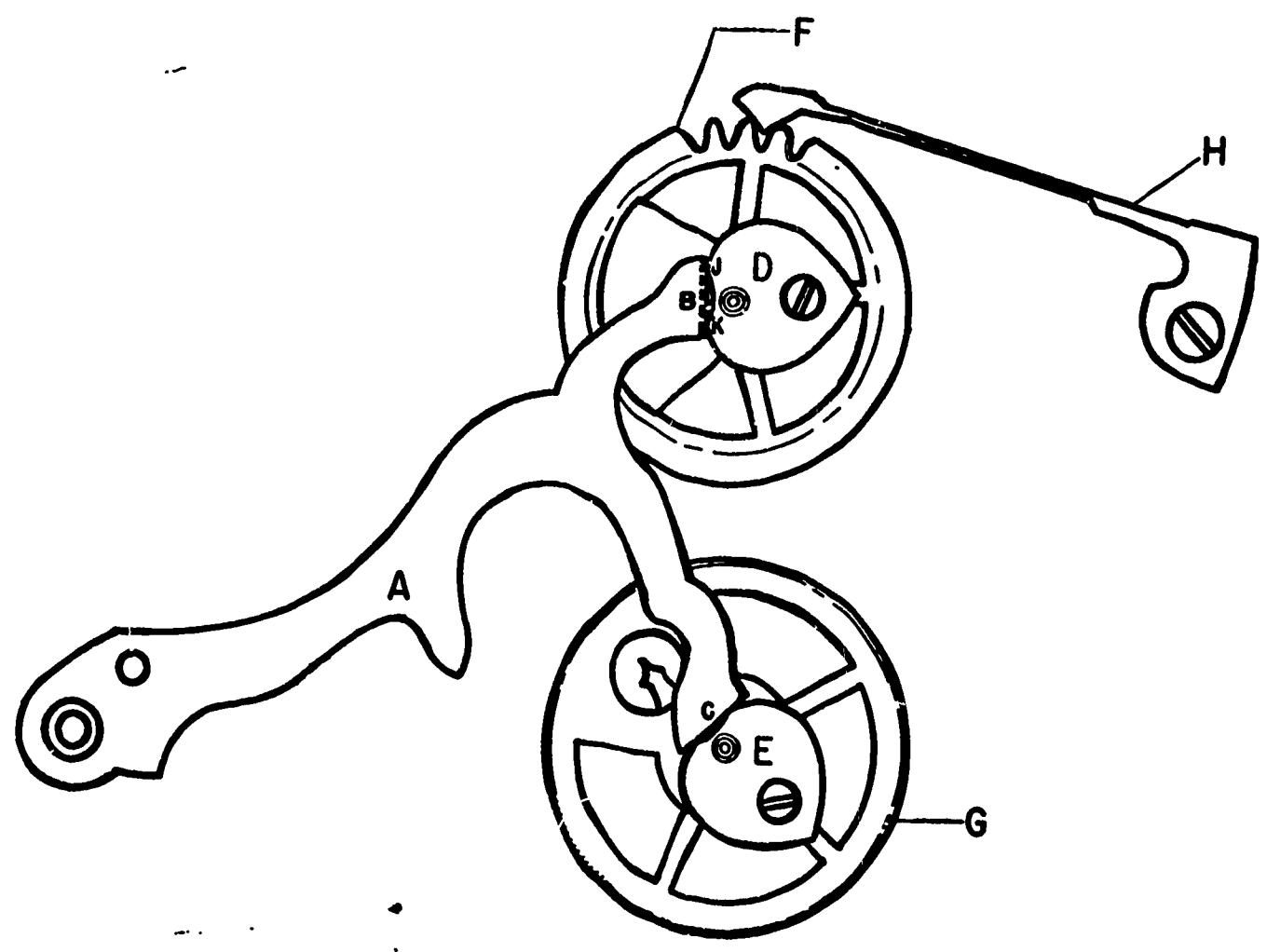
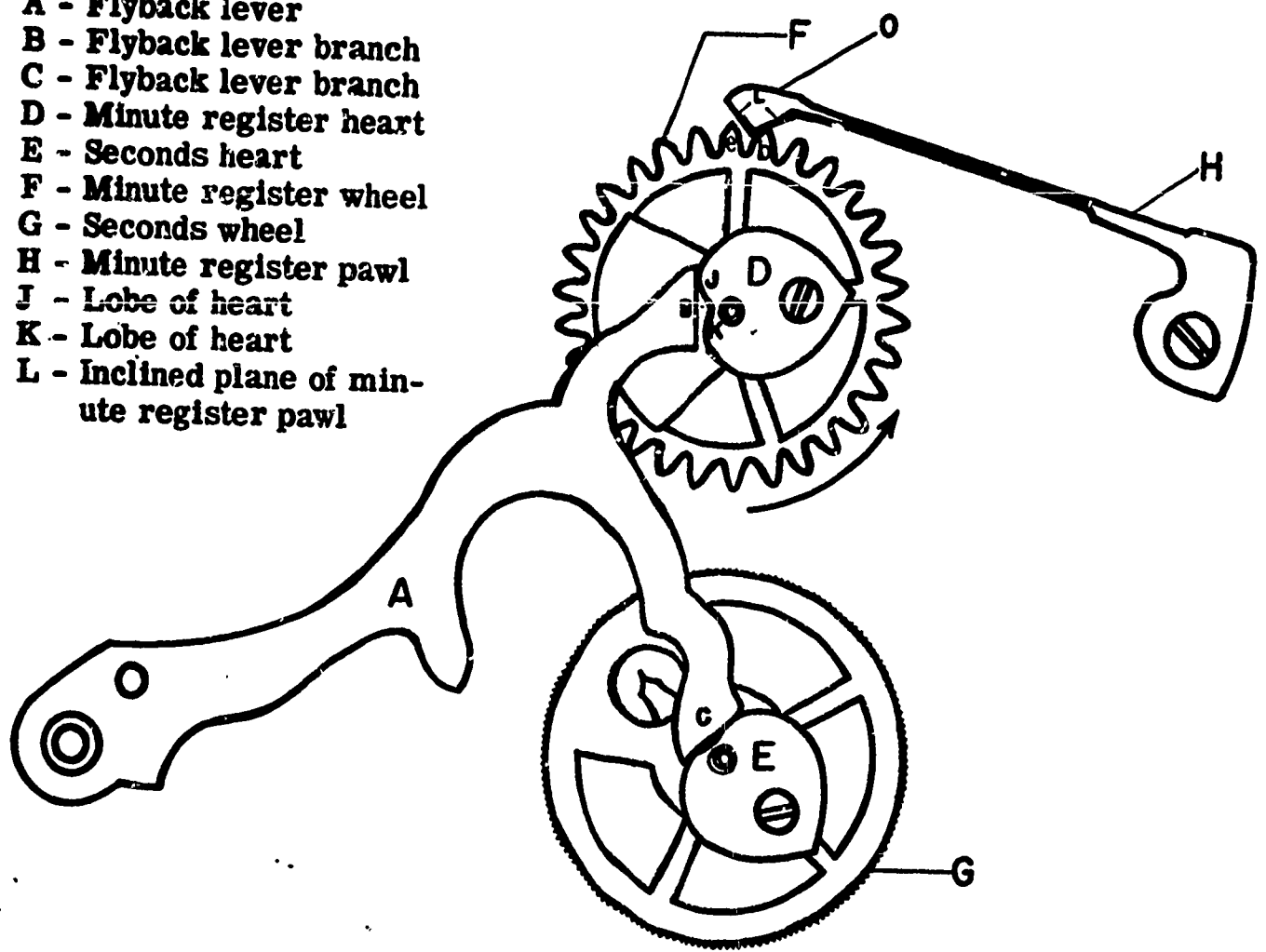

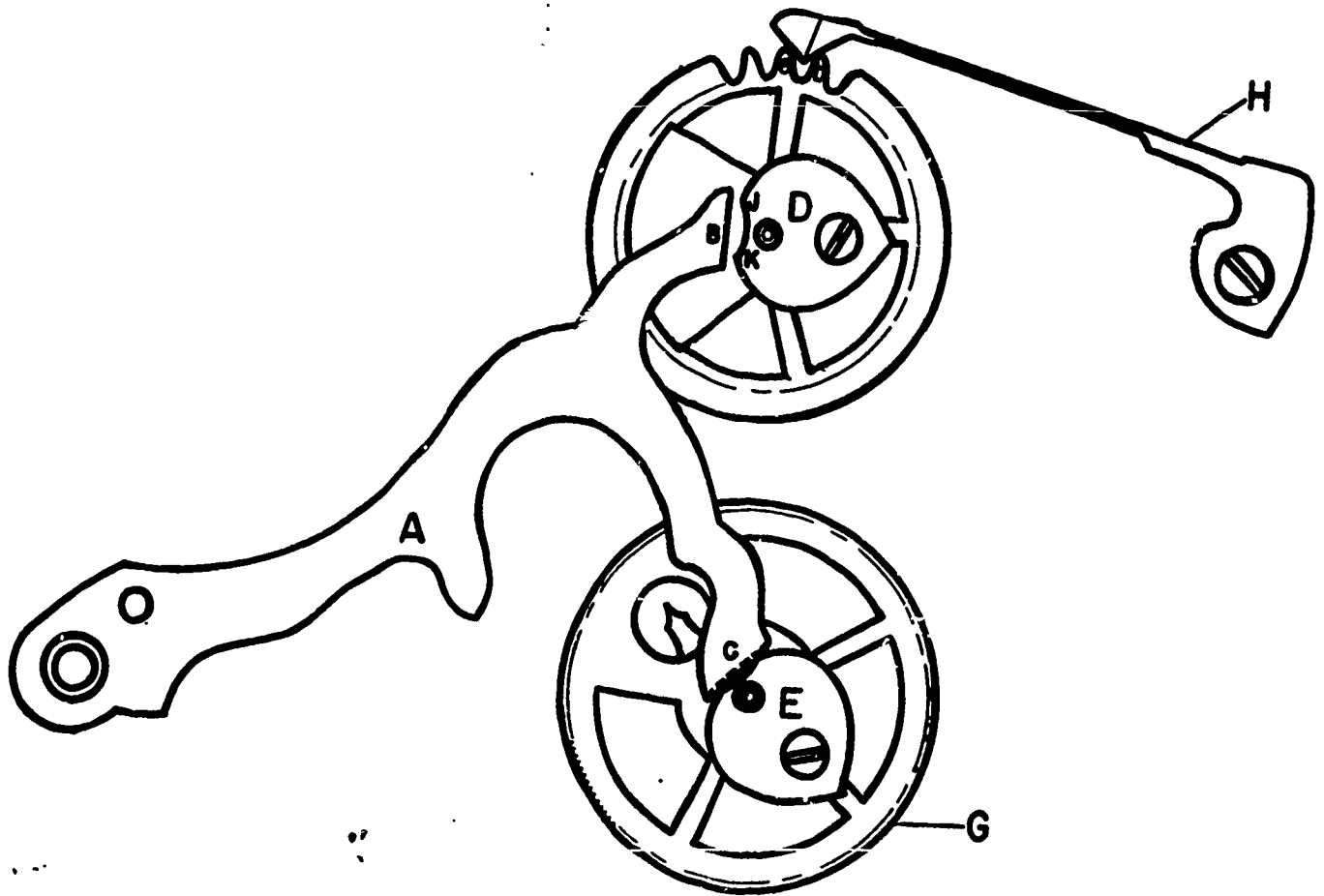
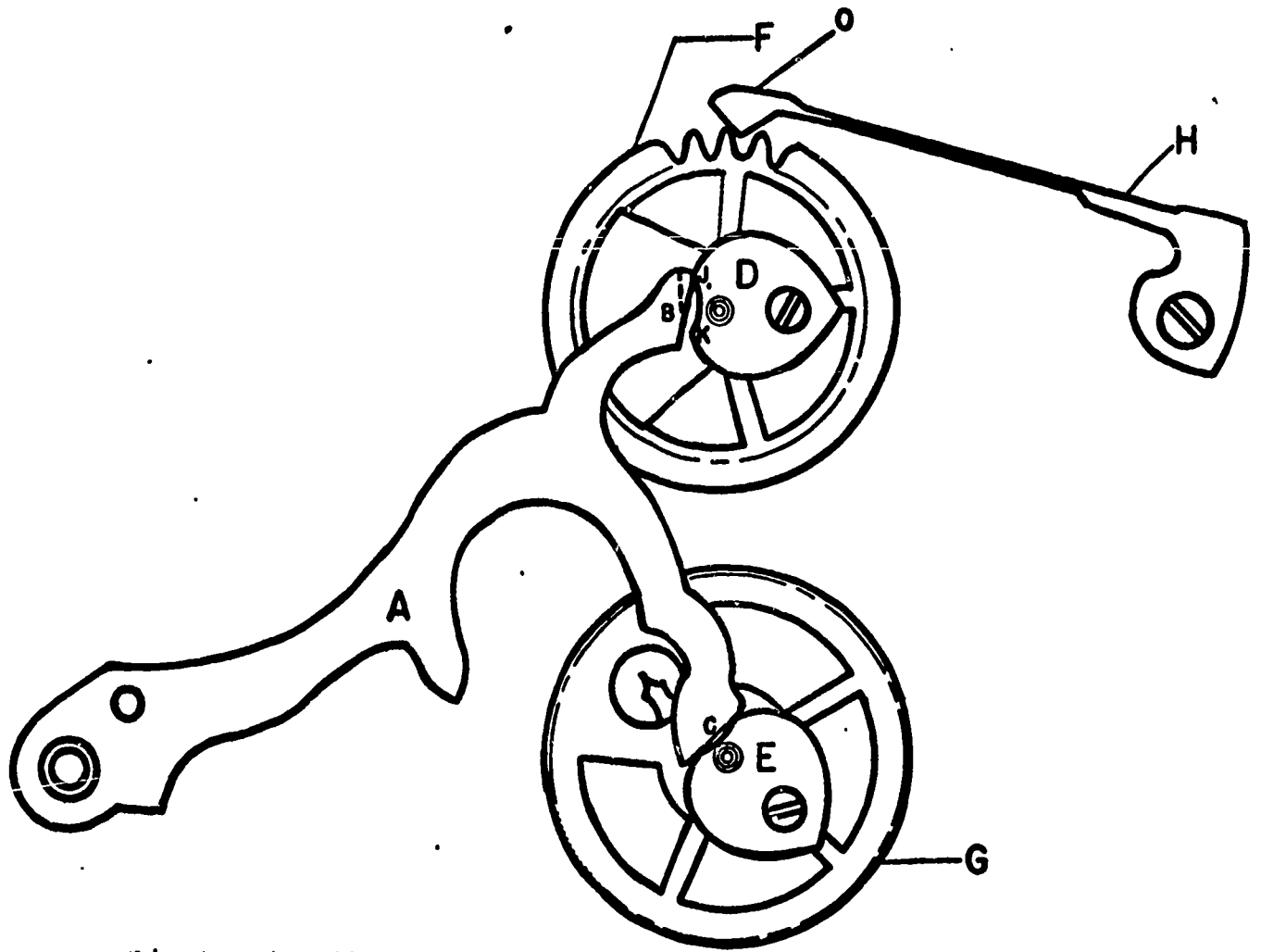

C - Branch of Flyback Lever
E - Heart

F - Lobe of Heart
G - Lobe of Heart

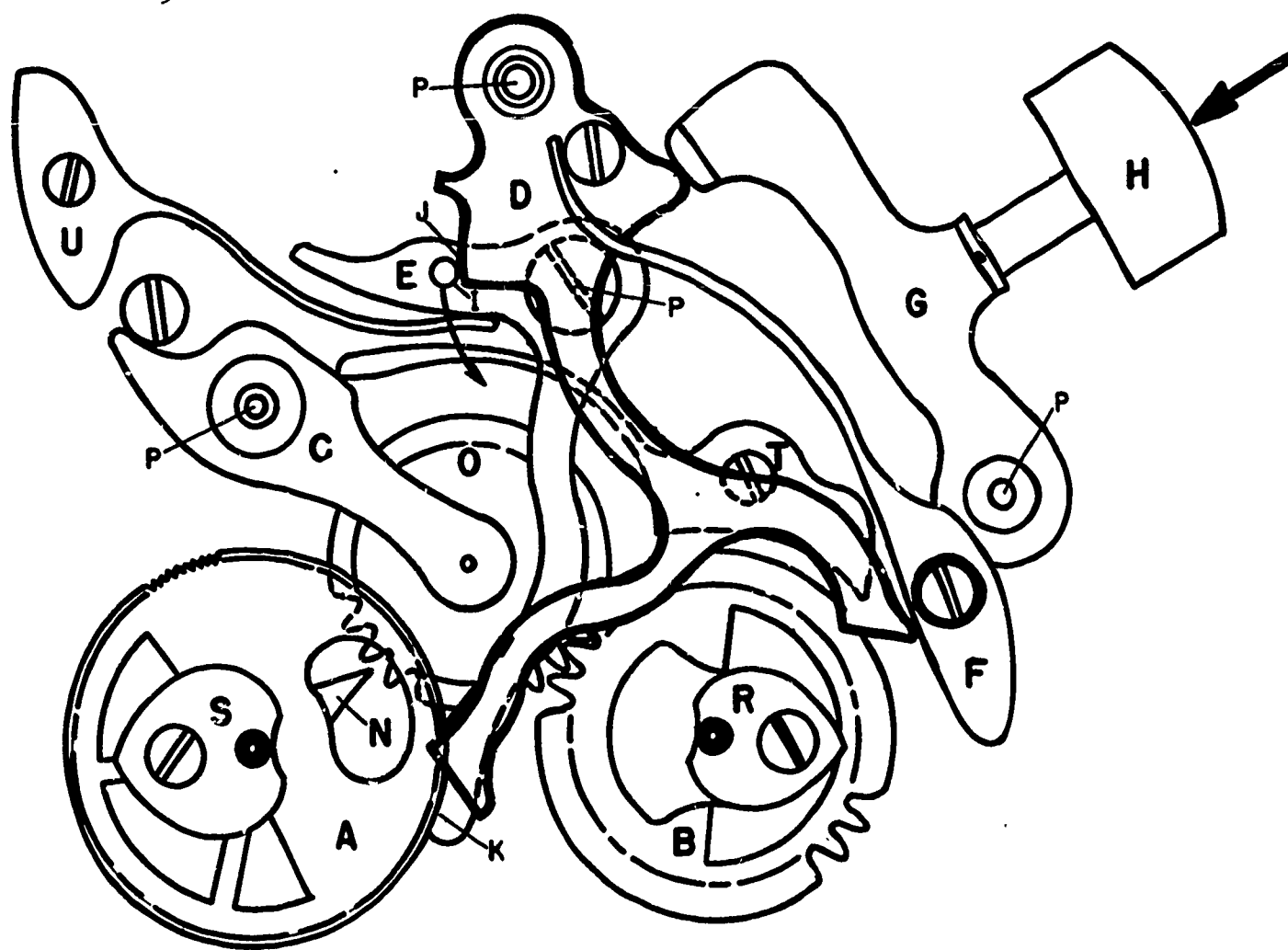
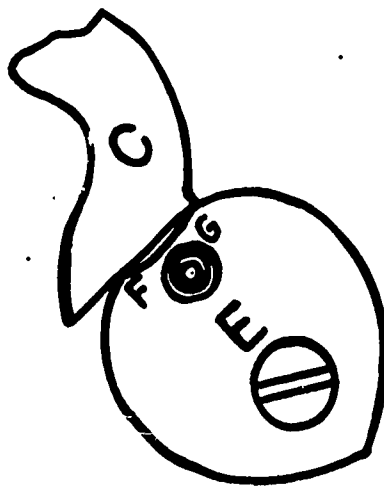
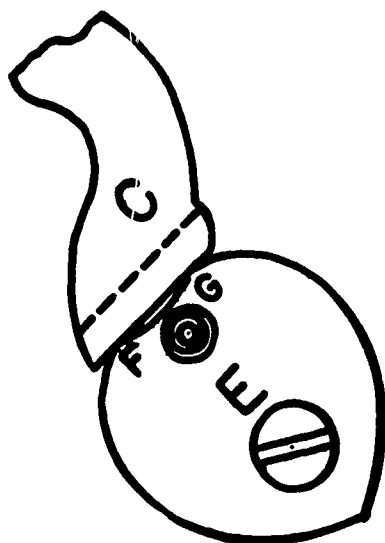

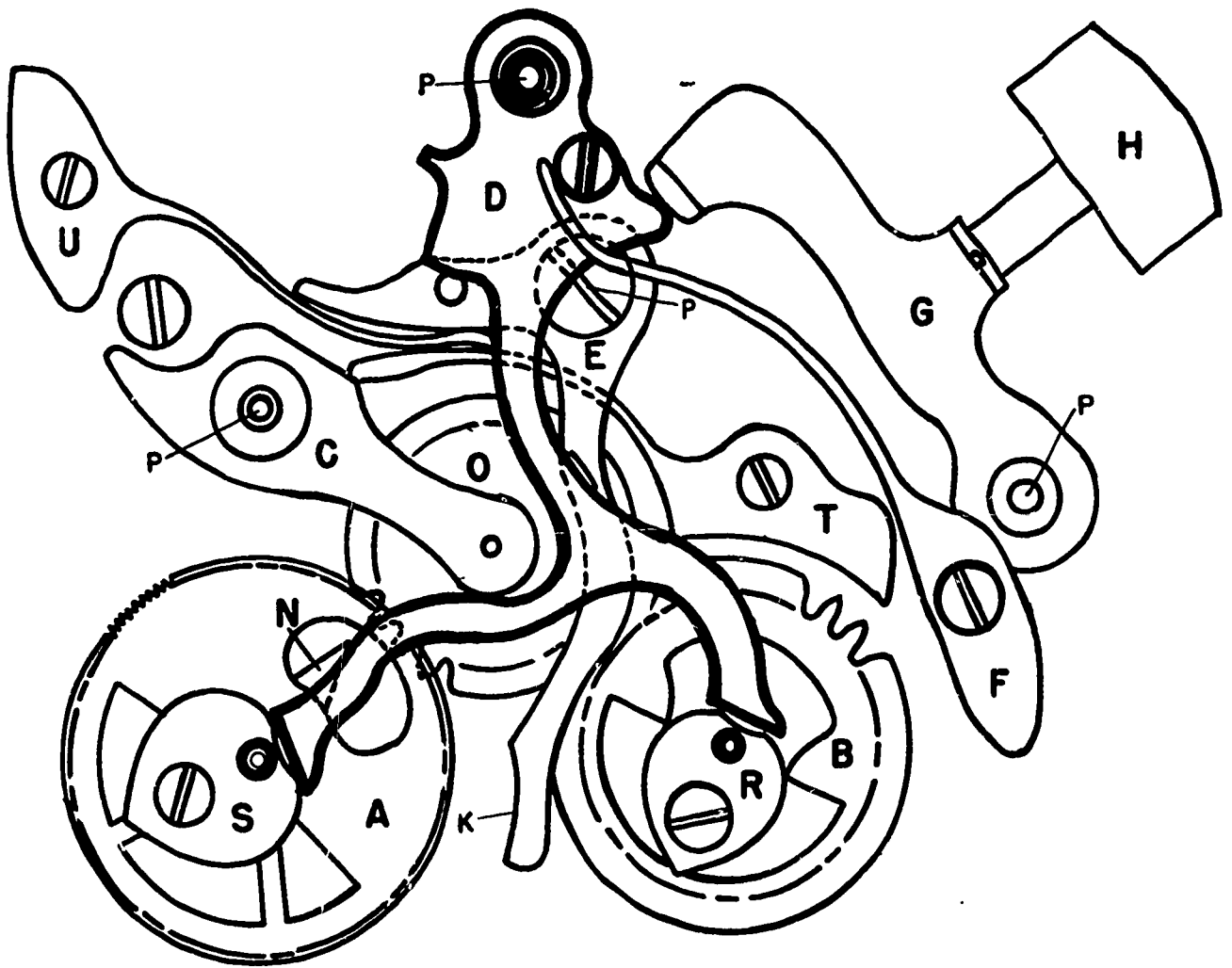
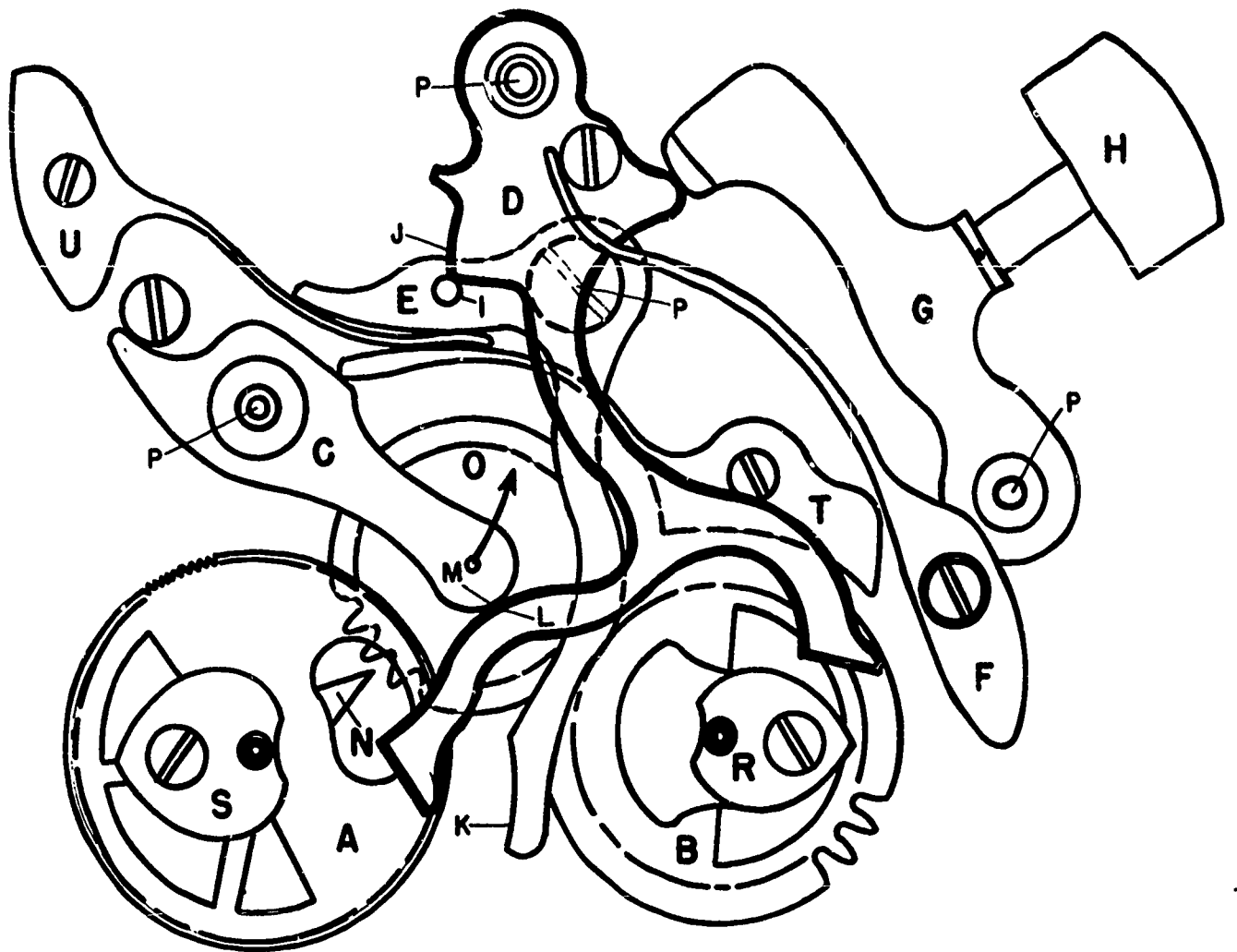

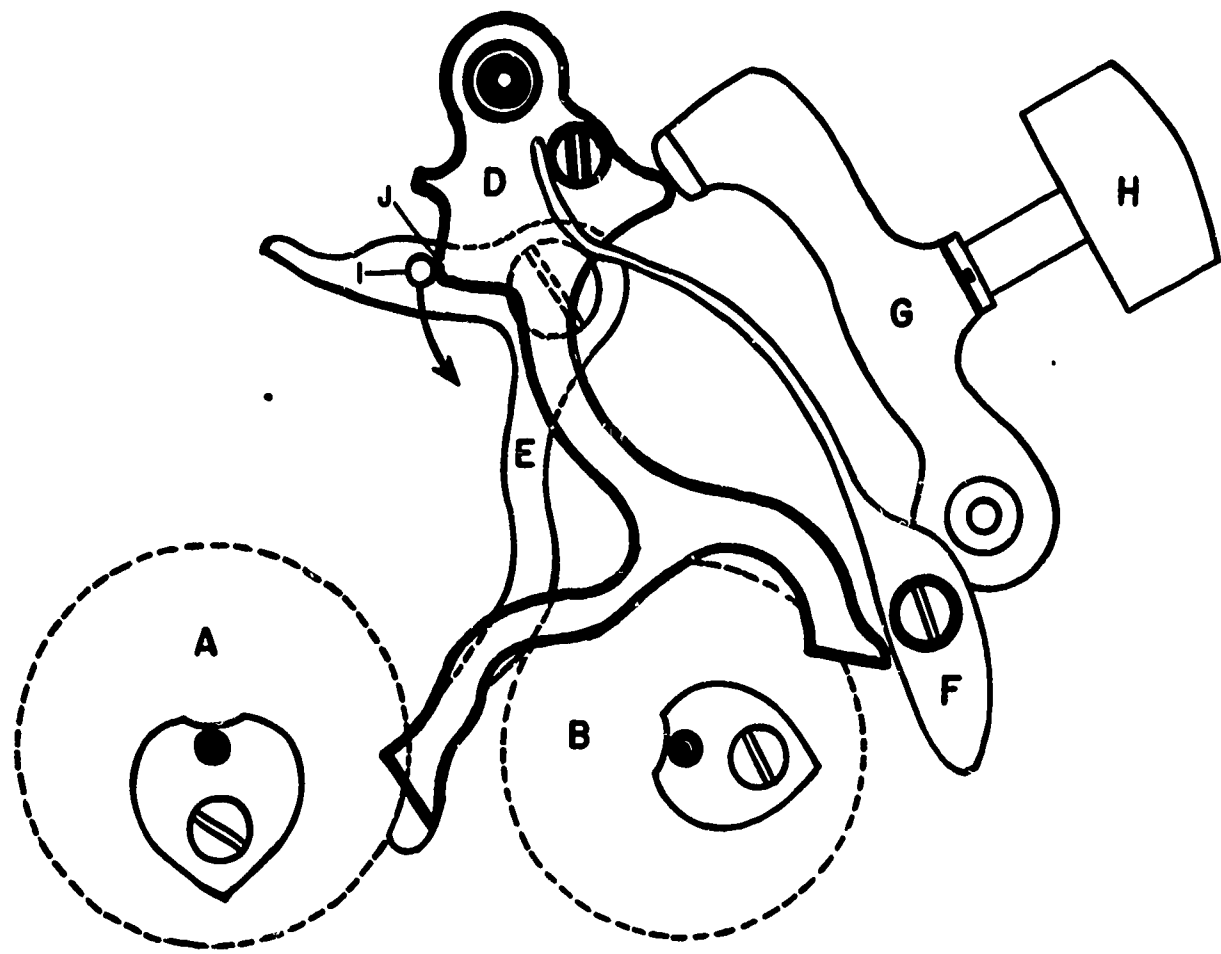
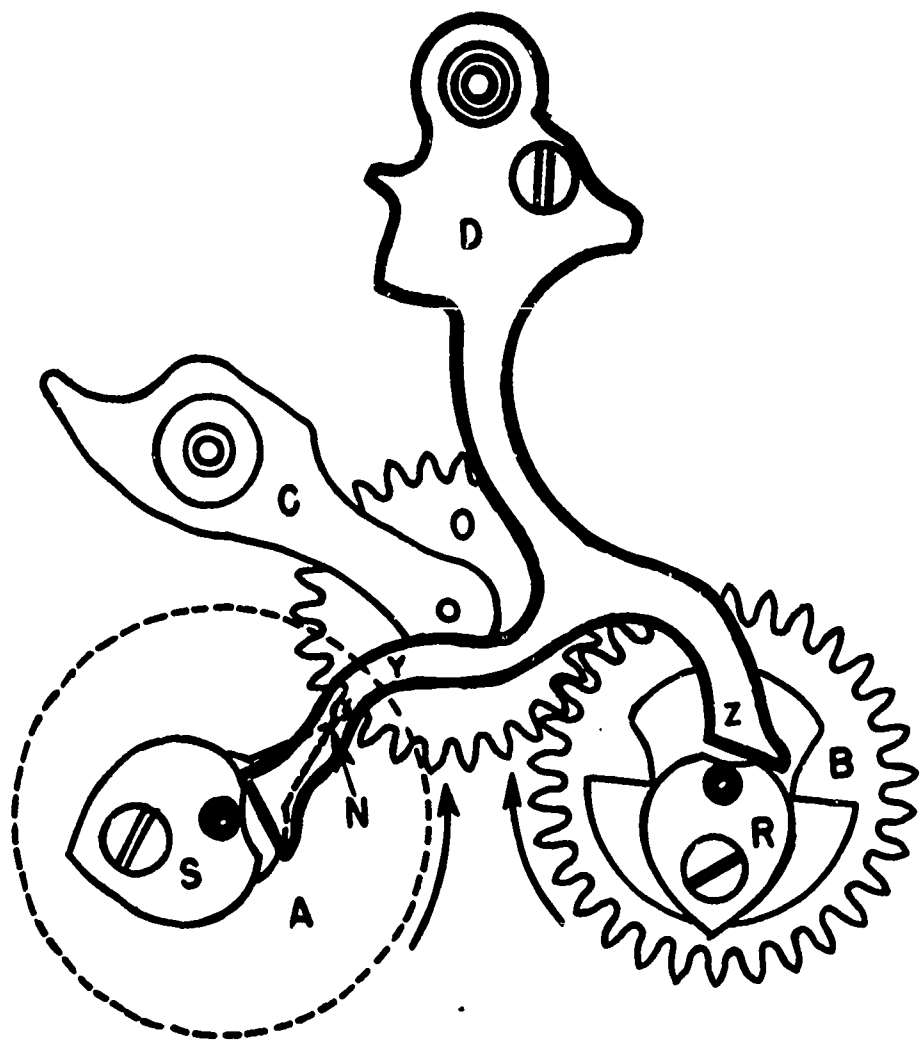

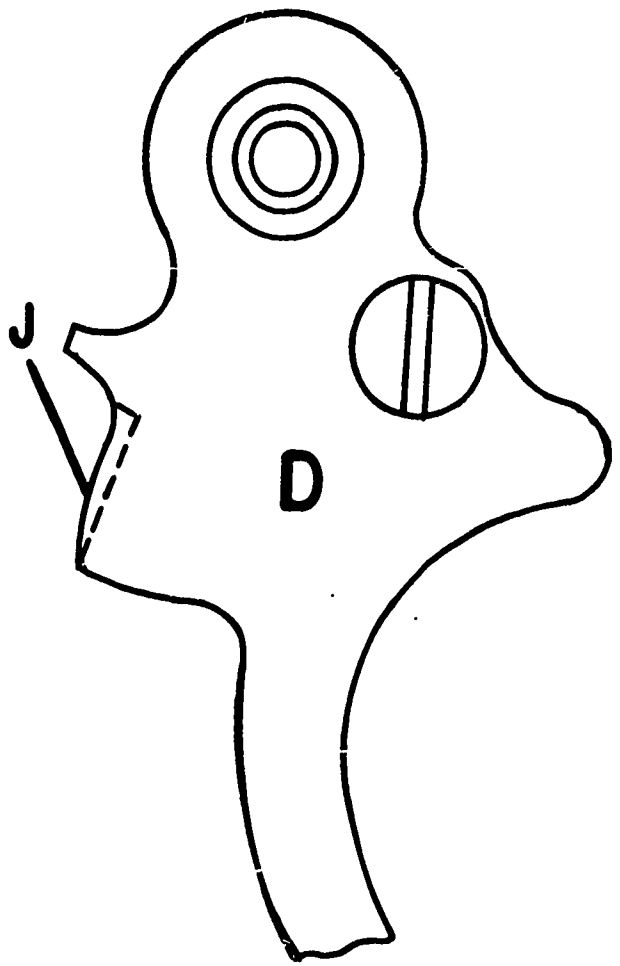
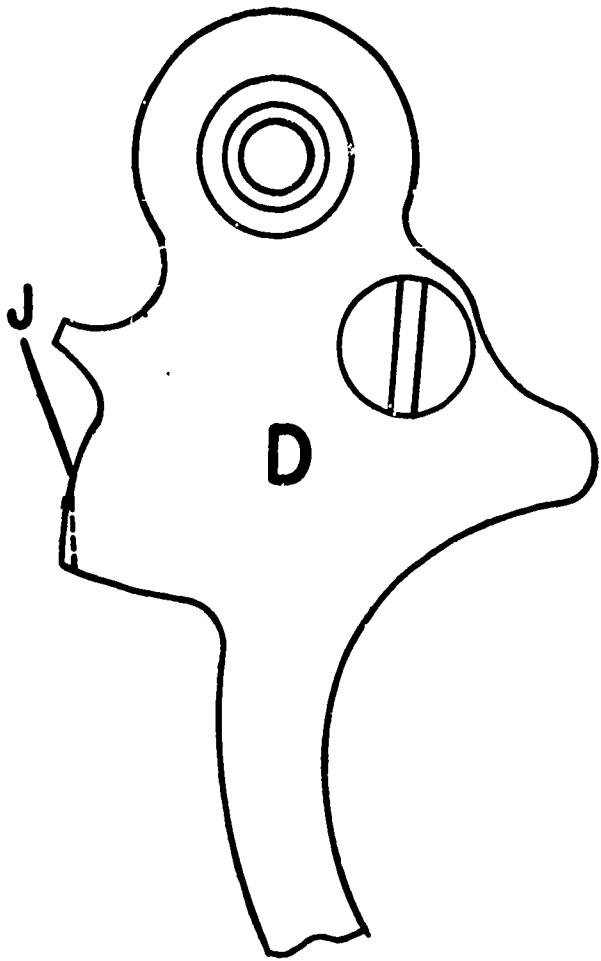

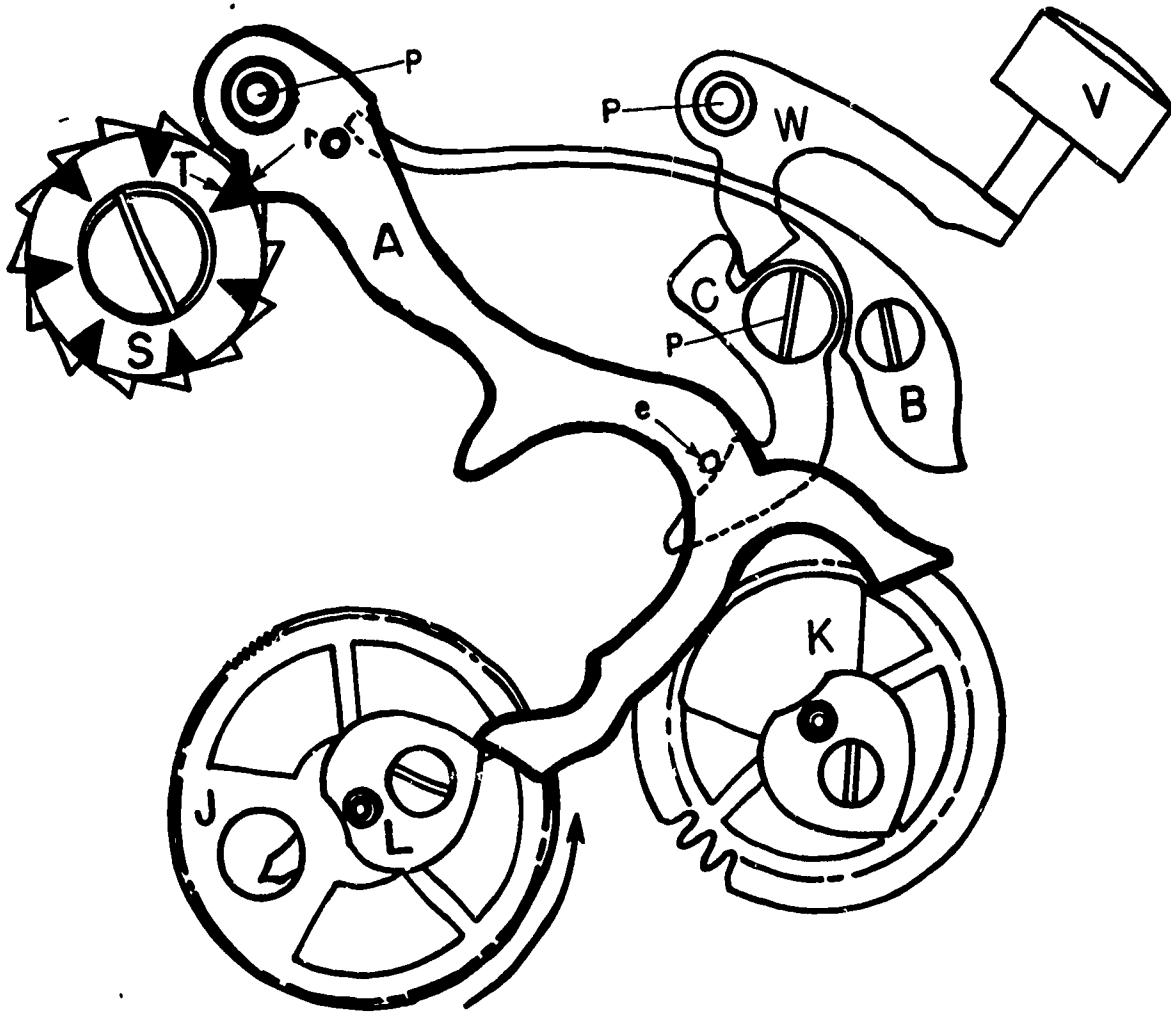
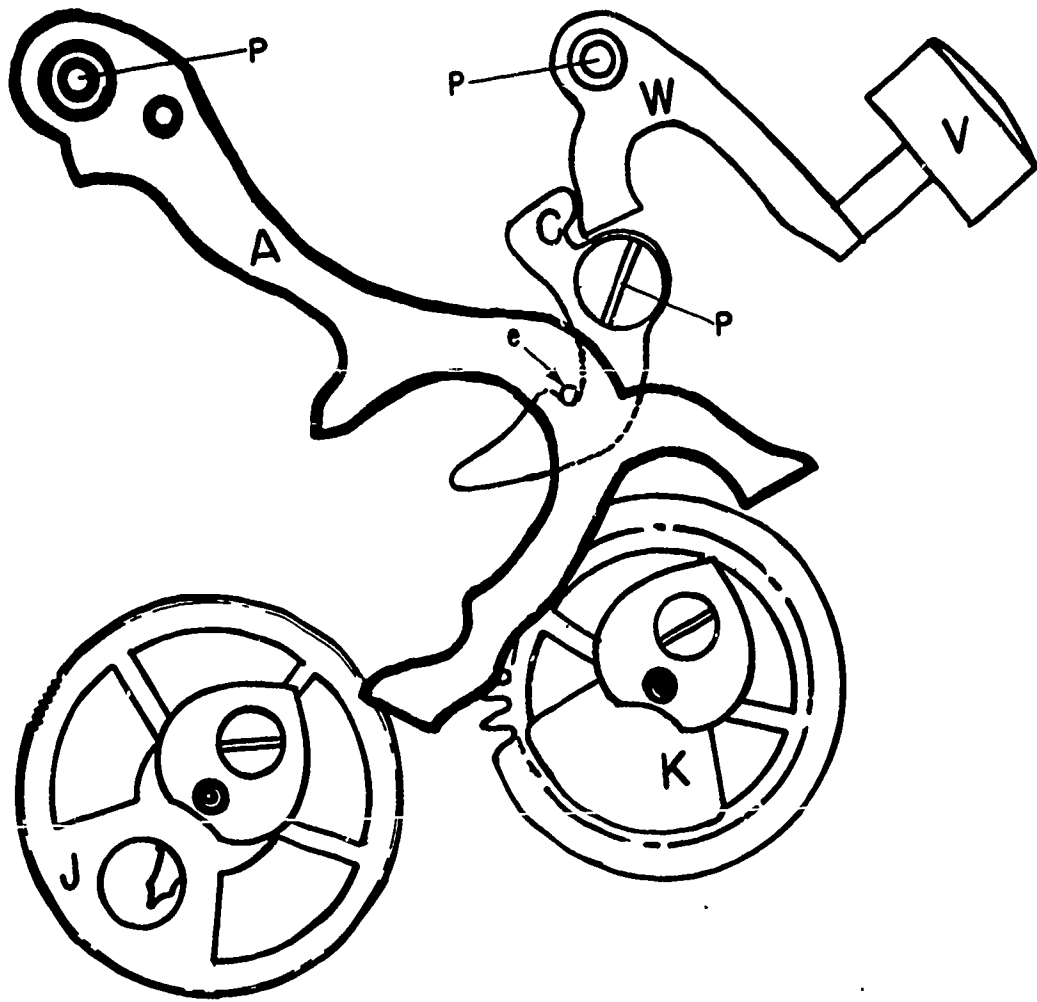

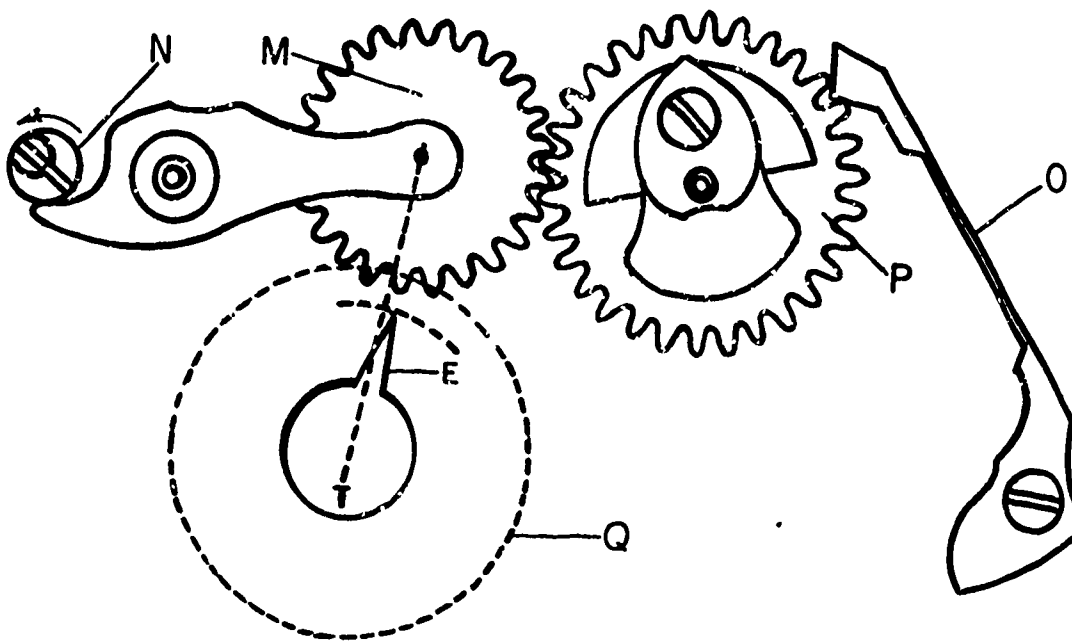
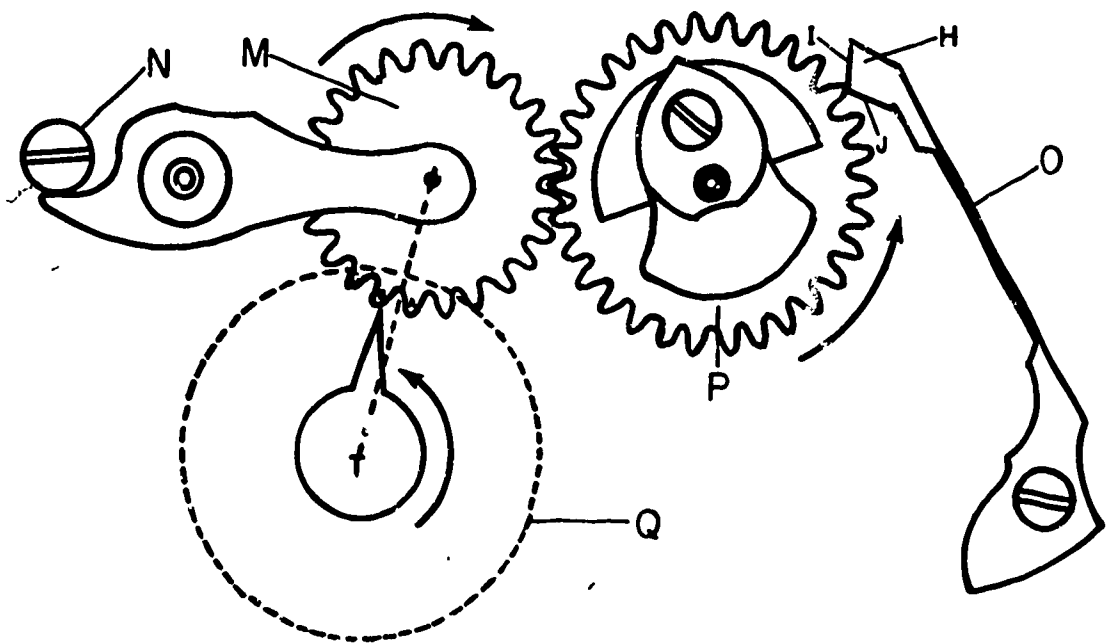
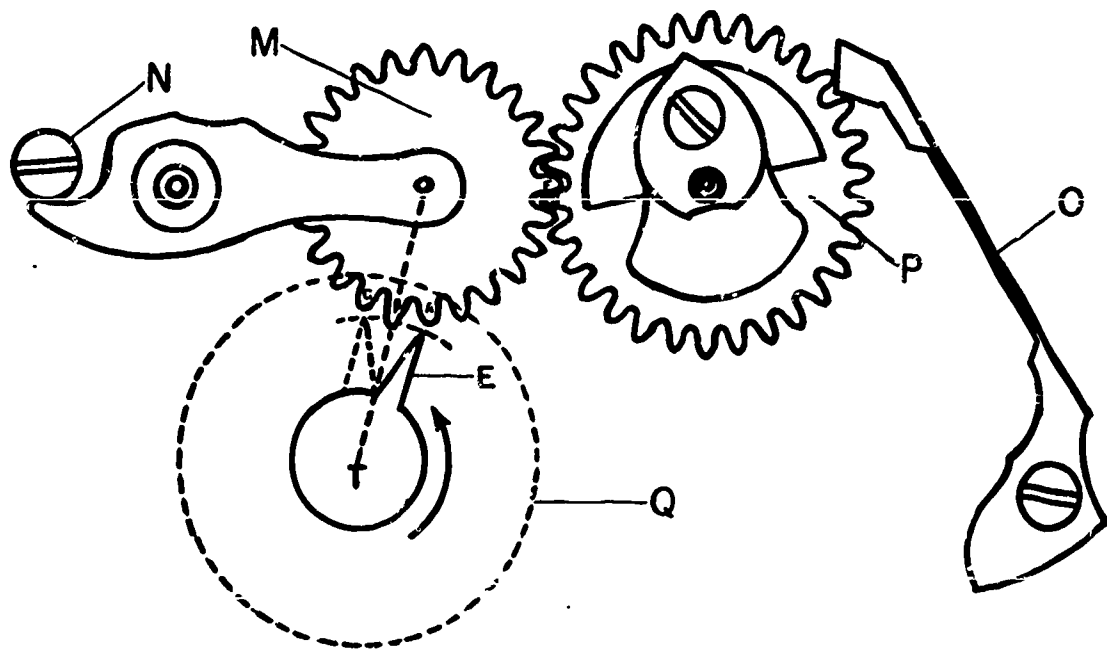

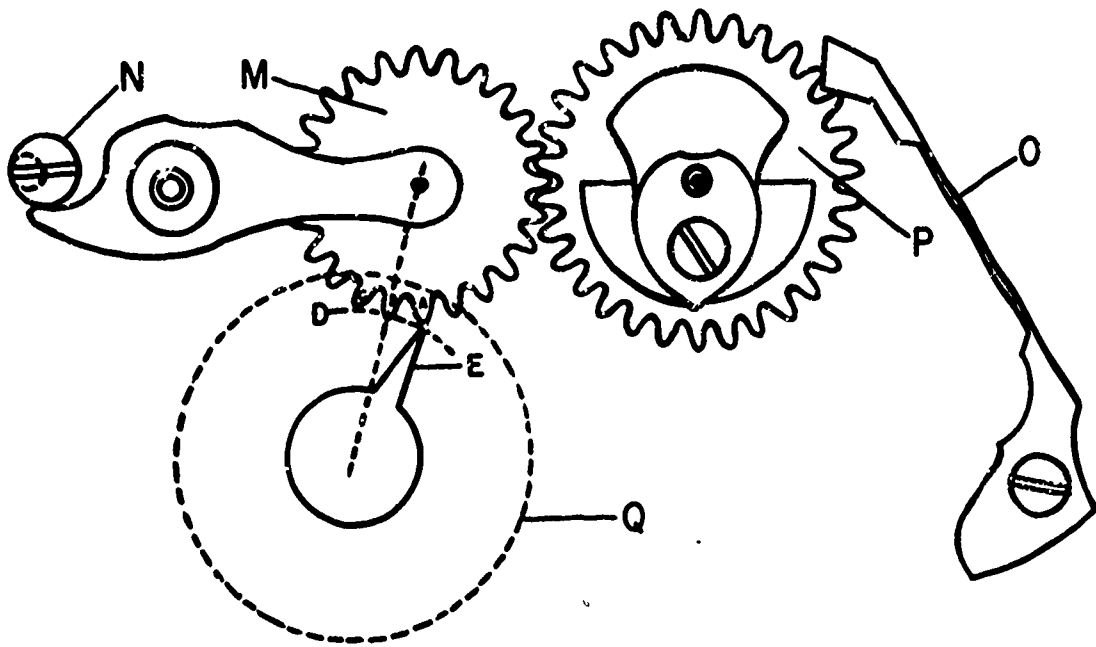
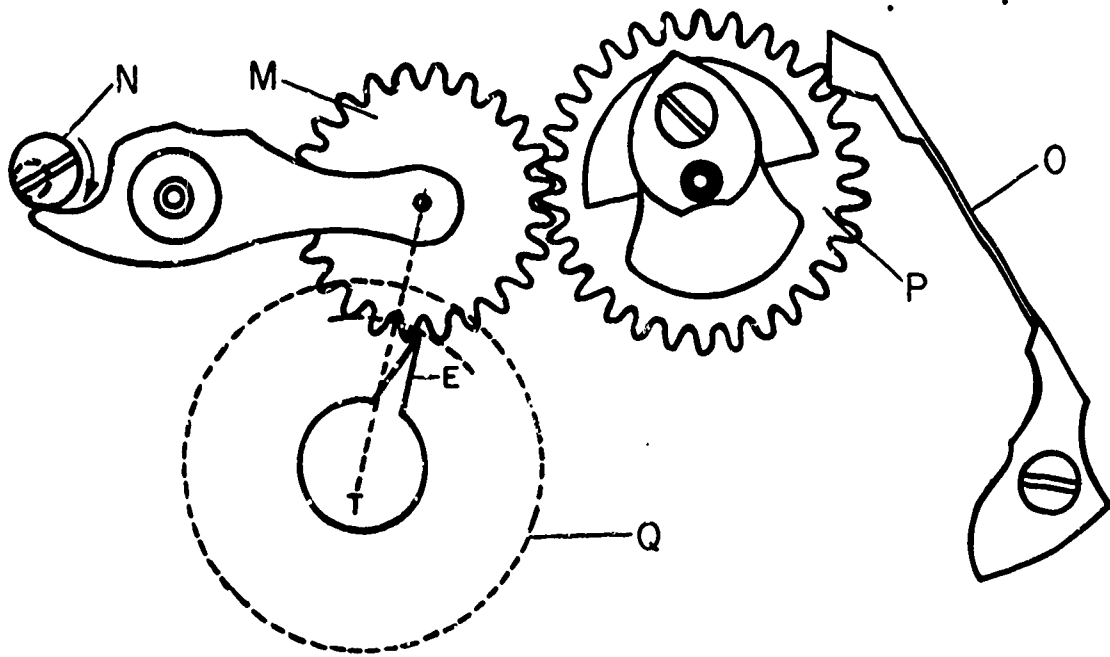
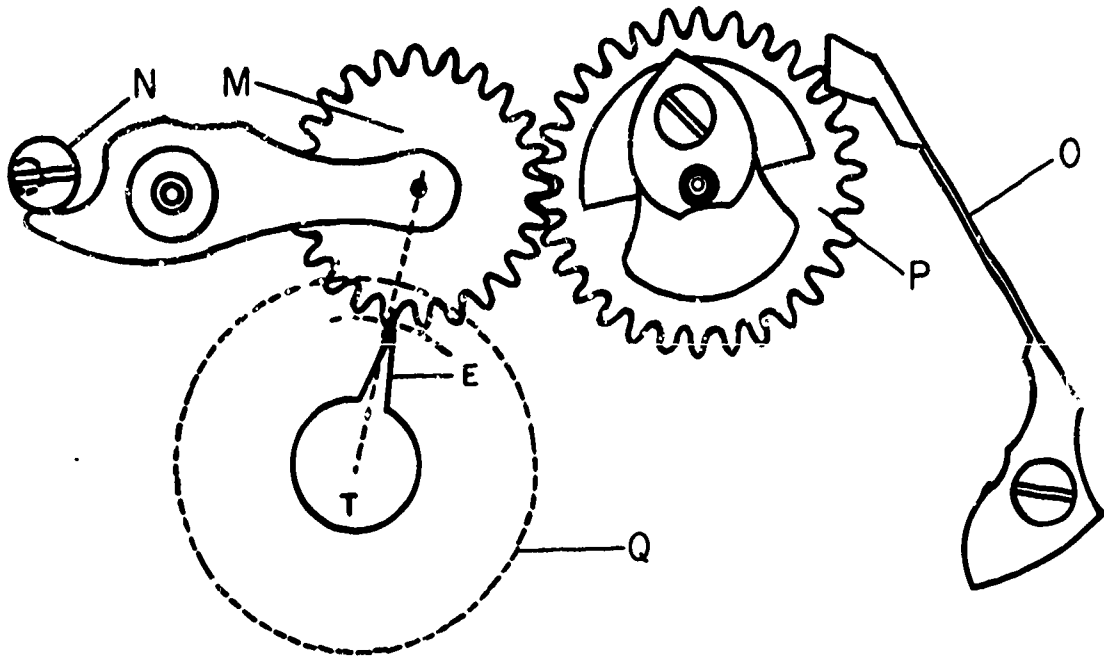

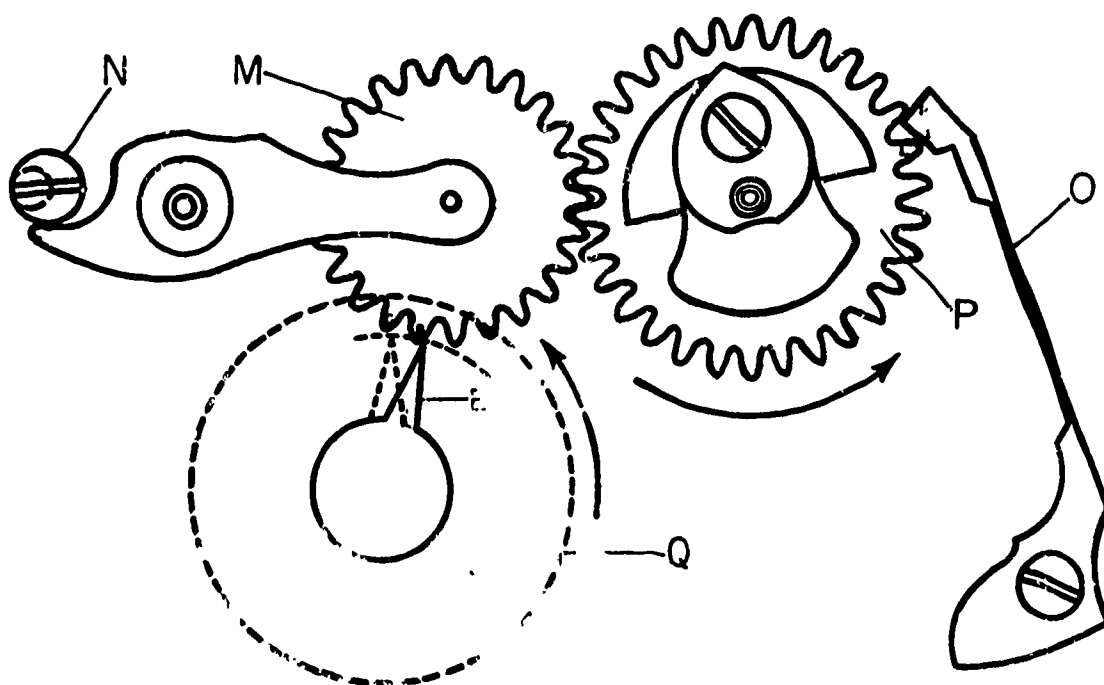
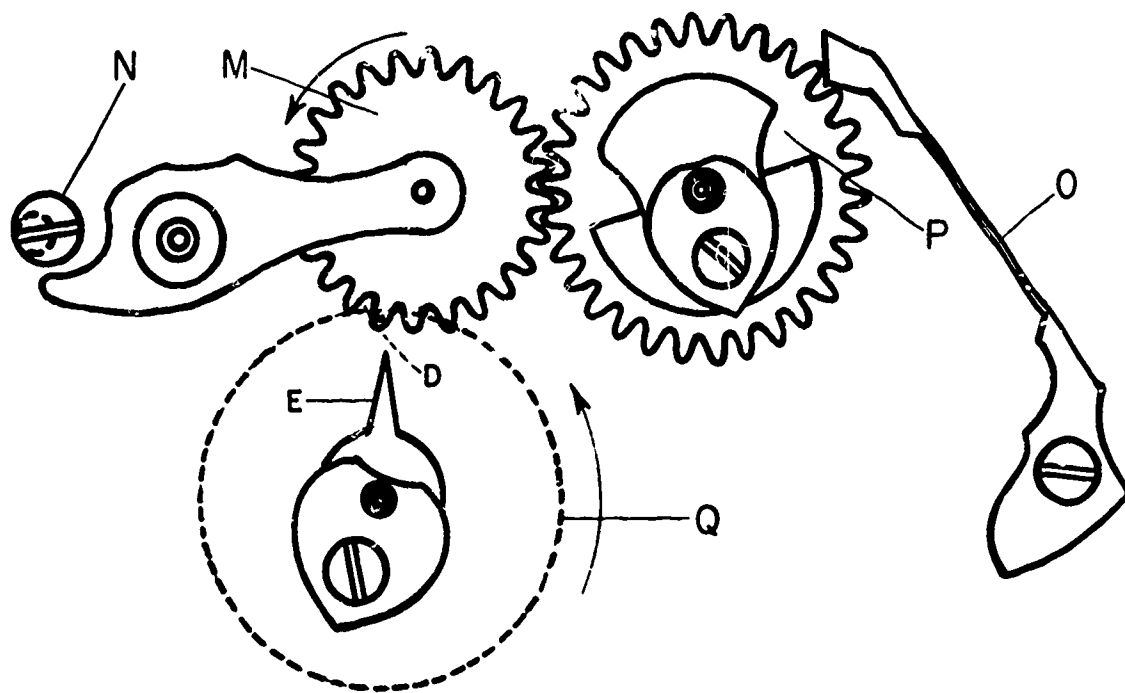
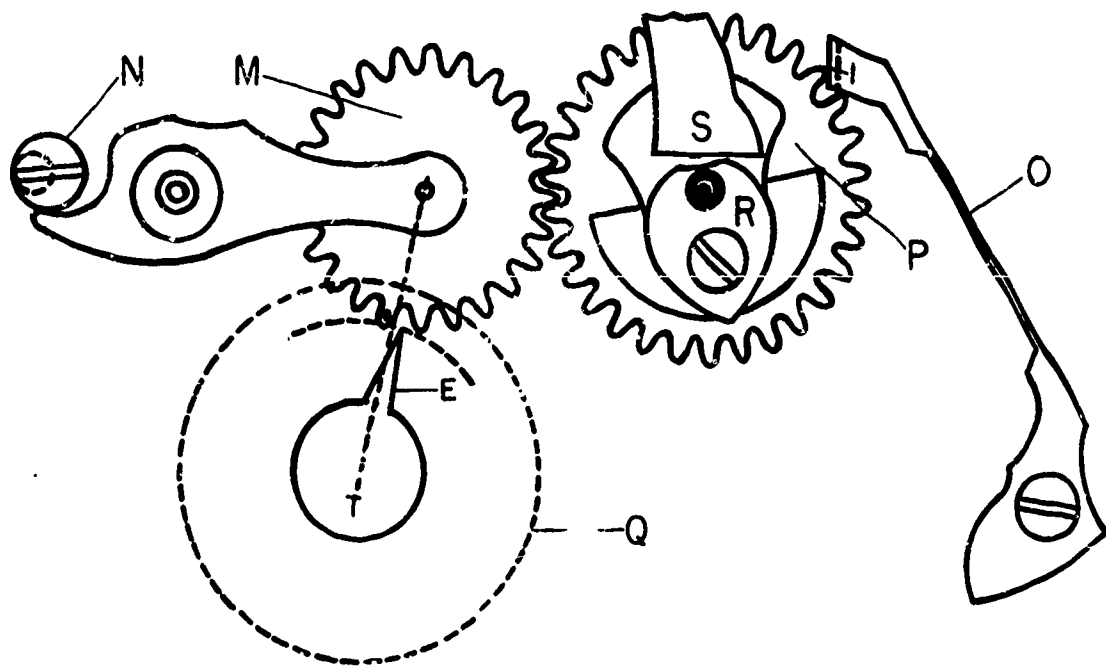

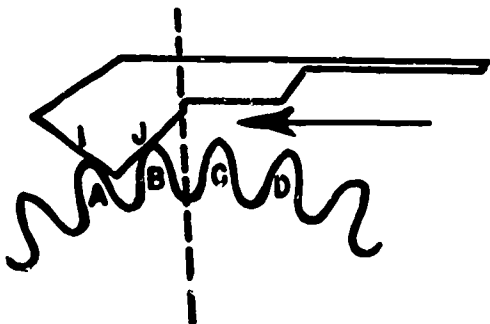
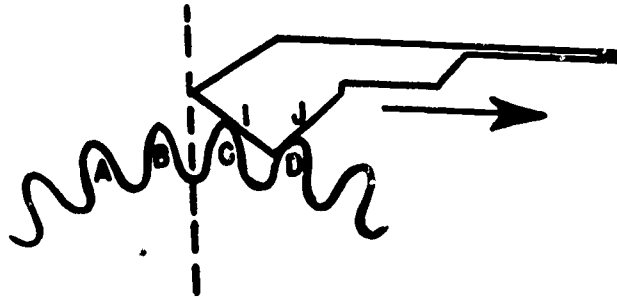
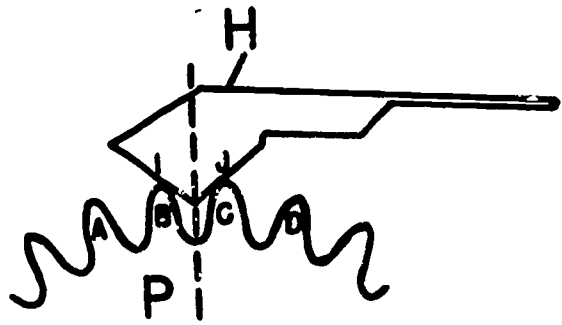
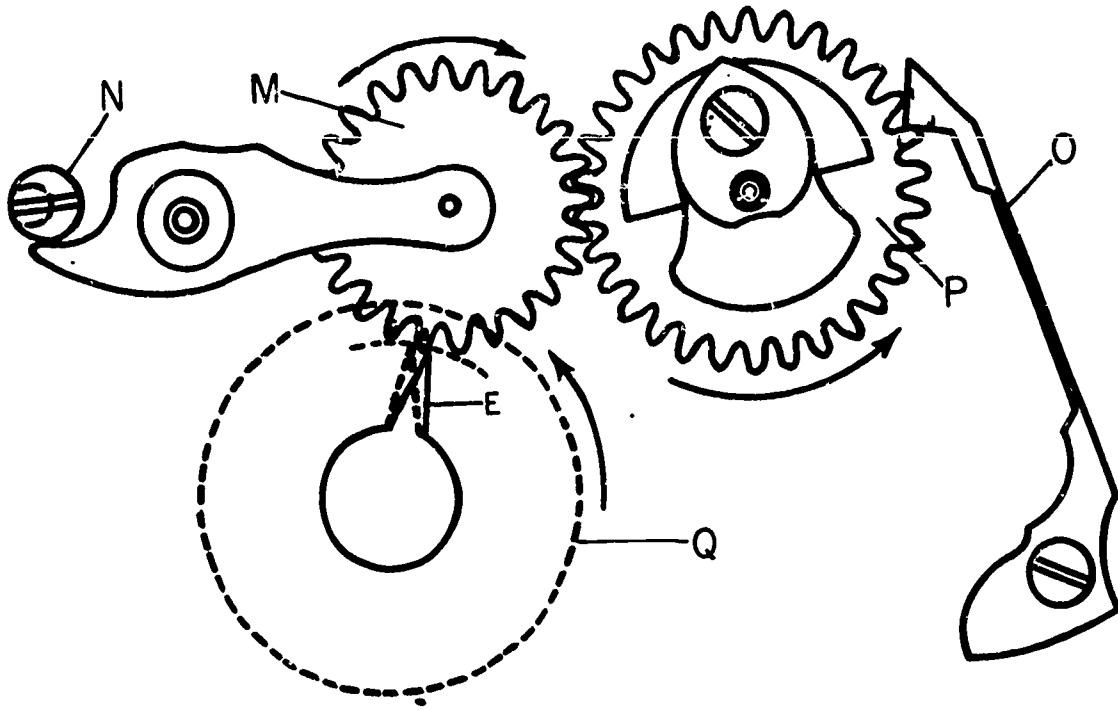

APPENDIX F

**COLOR CODE FOR WATCH BENCH DRAWERS,
PROPER ARRANGEMENT OF TOOLS IN BENCH,
AND DIAGRAM OF PUNCH ARRANGEMENT IN STAKING TOOL SET**

W

o

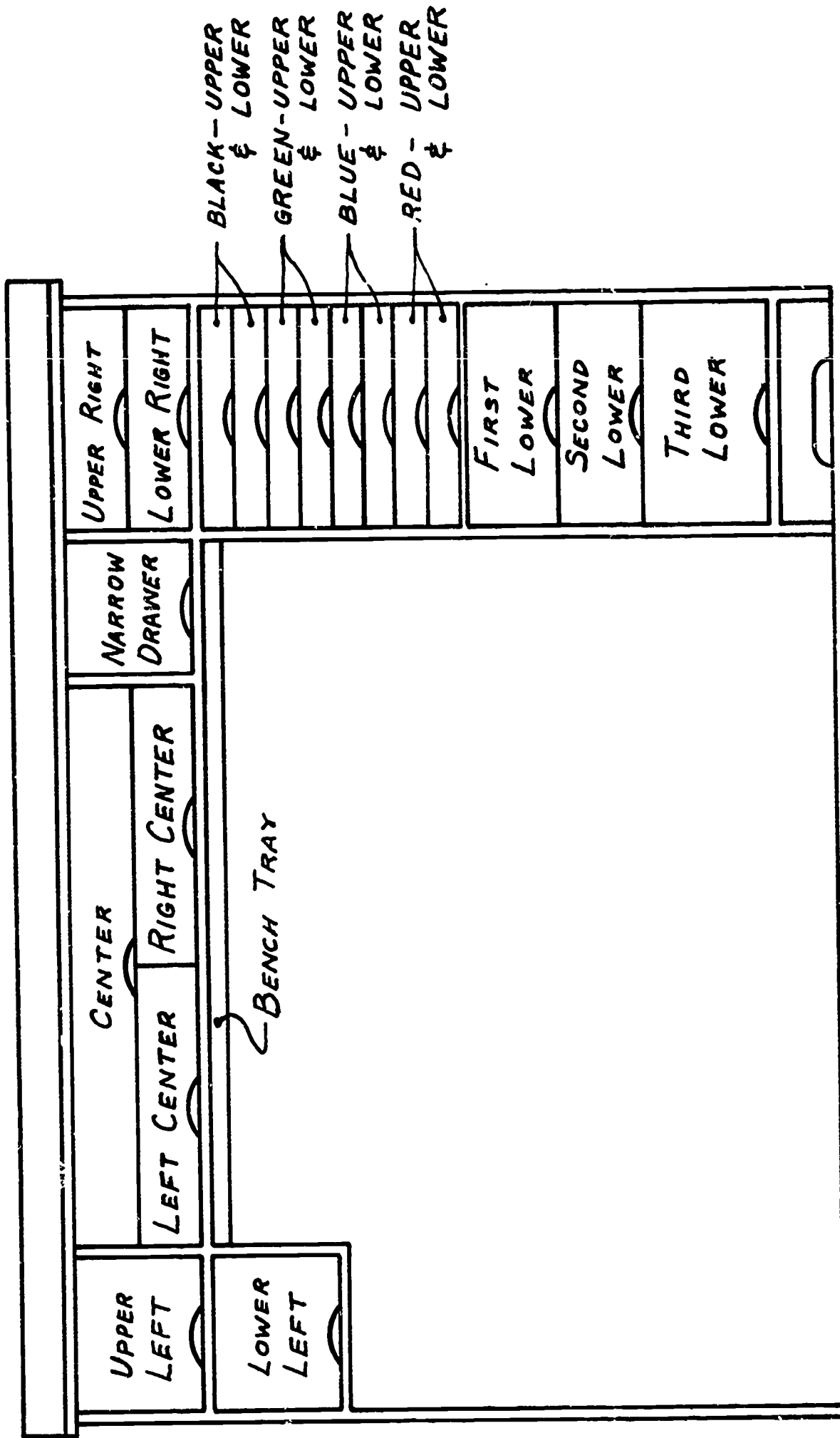

STUDENT TOOL LIST

TOP OF DESK

Lathe and motor
Oil stand and oiler
Bench plate
Staking set
Bench lamp
Bench vise
Bench pin

UPPER LEFT

No. 21 roller remover
No. 67 Calipers
Poising tool
Screw undercutter
Balance truck

LOWER LEFT

Alcohol lamp
Alcohol cup
One Dip
Oil 216
Oil
KT 22

CENTER

AN 11 Vigor anvils
Blowers
Screwdrivers
Hand remover
Wheel remover
No. 1 tweezer
Hairspring tools
Movement holder
Loupe
Dial brush

LEFT CENTER

Vigor material tray
Pallet warmer
Boxwood slip
Pivot loupe
Tweezer 351 and 384
Screwdriver sharpener
Graver sharpener
K & D staff remover

RIGHT CENTER

Leather buff stick
Glass brush
Jewel brights
Mainspring winders
Combination tool
Pithwood
Crystal cement
Sleeve wrench
Bench key

NARROW DRAWER

RM 365 Crystal lift
4G case opener

LEFT SIDE

Magnificuser

BENCH TRAY

Case opener - black
Vigor knife
Cannon pinion remover
Pliers No. 504 1/2 - 204 1/2

UPPER RIGHT

Screw plate
Triangle Arkansas stone
Jasper slip
Bell metal lap

LOWER RIGHT

Watch paper
Brass jaws

BLACK UPPER

Pin vise 656 and 661
Balance screwdrivers
Oil stone ST 776

BLACK LOWER

Hammer
Brass hammer
Brush

GREEN UPPER

All files

GREEN LOWER

Emery buff stick
Boley gauge

BLUE UPPER

Gravers

BLUE LOWER

Polish Cloth

RED UPPER

Clock screwdriver

RED LOWER

FIRST LOWER

Lathe chucks
Tweezer
Pocket watch case opener

SECOND LOWER

Stack-up watch trays
Micrometers
Ring clamp

THIRD LOWER

Pliers
Saw frame

80 Punch

C & E MARSHALL STAKING SET

M5

E1 A10 A20 A30
E3 A8 A19 A29
2H A6 A18 A28
E5 A4 A17 A27
E7 1G A16 A26
E9 3G A15 A25
C9 F2 A14 A24
C7 F4 A13 A23
C5 A12 A22
3C 13 11 6M A11 A21

2 3 4 5
12 11 6 7 8

B30 B20 B10 K3 K1
B29 B19 B8 N4 J4
B28 B18 B6 N3 J2
B27 B17 B4 N2 D3
B26 B16 N1 D5
B25 B15 D7
B24 B14 D9
B23 B13 M3
B22 B12 M2
B21 B11

M4 9
19 13 14 16 18
24 25 20 21 17

APPENDIX G

**SAMPLES OF QUESTIONS USED IN WRITTEN EXAMINATIONS
FOR HOROLOGICAL LABORATORY STUDIES**

SAMPLES OF QUESTIONS USED IN WRITTEN EXAMINATIONS
FOR HOROLOGICAL LABORATORY STUDIES

Listed below are samples of some of the test questions used in the first written examination which was administered to the students on Friday, March 10, 1967.

- * What tool do you use to bend the balance wheel in order to bring it to perfect trueness?
- * What is the name of the most popular type of balance wheels used in watches today?
- * What is the purpose of a compensating balance?
- * Name three timekeeping elements used in timekeeping instruments today.
- * What is meant by capillary attraction?
- * When poising a balance wheel, how do you determine the heavy spot?
- * What tool do you use to remove the hairspring from the balance wheel?
- * How do you determine the proper position to place the hairspring on the balance wheel?
- * How do you determine if a watch is in approximate beat?
- * What do you turn in order to adjust the watch to perfect beat?
- * Give the definition of the word "isochronism".
- * Give the definition of the word "time".
- * Give the definition of the word "horology".
- * How should the screwdriver be selected in reference to the screw on which it is to be used?
- * What two tools are used in removing a balance wheel screw?

Listed below are samples of some of the test questions used in the second written examination which was administered to the students on Friday, April 7, 1967.

- * The pressure of the escape tooth on the locking face of the pallet stone and the angle the pallet stone is set in the slot of the pallet fork determine the force of _____.
- * The space between the guard pin and the safety roller when the fork is against its banking pin is called _____.
- * a) Checking the amount of lock when the corner of the fork slot is brought into contact with the face of the roller jewel is termed _____.
- b) How much lock should be present when this check is made? _____
- * What is the proper amount of drop lock that should be set in the escapement?
- * What test is taken to determine the proper length of the guard pin?
- * Why is slide necessary?
- * The purpose of the escapement is to change the _____ motion of the train into the _____ motion of the balance.
- * When turning steel, the cutting edge of the graver should be adjusted to what height?
- * In order to insure trueness of the chuck in the lathe, what two surfaces should be checked before inserting the chuck in the lathe?
- * In turning on a watchmaker's lathe, name the two types of gravers that are used.
- * When turning brass bushings, how does one obtain a high finish on the bushing?
- * When tempering steel, what color is the steel brought to that is considered spring steel temper?
- * When hardening a piece of steel, the steel is heated to a _____ and then quenched in water.
- * What are the two measuring instruments generally used in lathe work?
- * When fitting a piece of material in a chuck, how should it fit?

Listed below are samples of some of the test questions used in the third written examination which was administered to the students on Friday, May 12, 1967.

- * When straightening a hairspring in-the-flat, the corrective bend should be made how many degrees from the widest point of separation of the coils?
- * When putting a watch in perfect beat, if it is found that the escape tooth travels further up the impulse face of the discharge stone than the receiving stone, will the collet of the hairspring be moved in a clockwise or counterclockwise direction?
- * When considering the poise of the balance wheel dynamically, at what degree of motion will all poise errors equalize themselves?
- * When working on the quadrant of the hairspring, should it be adjusted so that the quadrant rests against either the boot or the pin, or should it be adjusted so that the hairspring does not touch either boot or pin when the balance is at rest?
- * When working on a hairspring to straighten it in-the-round, the first correction that is made is to work on the first bend that is closest to the collet or to work on the first bend which is closest to the end of the hairspring?
- * What is the term used when referring to a condition where the pallet lever is against the banking pin but the escape tooth cannot drop off the pallet stone?
- * To adjust the depth of penetration of the pallet stones into the periphery of the escape wheel, _____ is checked.
- * What two things control the amount of guard clearance?
- * When bending the hairspring to raise the overcoil above the level of the hairspring, how many tweezers are used?
- * What kind of clearance should exist between the second hand, hour hand and minute hand on a watch?
- * How do you determine the proper position to place the hairspring on the balance wheel?
- * What is meant by the concentric vibrations of a properly formed overcoil hairspring?

Listed below are samples of some of the test questions used in the fourth written examination which was administered to the students on Tuesday, June 20, 1967.

- * List the three types of rivet staffs.
- * List the four staking set punches used in staffing watches.
- * List the three punches that are used to rivet a safety staff.
- * If a solid balance is found to be out-of-round, would this normally be corrected in the truing calipers?
- * In order to remove a balance staff from a balance wheel, there are two methods of cutting out a balance staff. These are:
- * List the steps that you would take in the process of turning a balance staff to fit a particular watch.
- * List the steps that are normally taken in manufacturing a stem.
- * What part of the watch is considered the timekeeping element?
- * What is an olive hole balance jewel?
- * What is the technical term used to indicate the force that holds the oil globule between the curve balance jewel and flat cap jewel?
- * What tools are used to polish balance pivots?
- * To close a collet, what punches are used in the staking set?
- * What is the purpose of vibrating a hairspring to a balance wheel?
- * How much oil should be placed in the train jewels of a watch?
- * What kind of punches or stumps are used in the staking set to tighten a cannon pinion?
- * If a cannon pinion is too tight, how is it loosened?
- * What kind of punches are used in the staking set to close the holes of a barrel?
- * What two systems of measurements are used to measure mainsprings?
- * What area of the barrel should the mainspring occupy?
- * What is the ratio between the cannon pinion and the hour wheel?
- * What is the purpose of a Geneva stop works?

- * If one has to replace a roller jewel, how is the size of the jewel determined?
- * List the steps that are normally taken to adjust an escapement in a watch.
- * When cleaning a watch, list all the checks that you can think of that you would make when assembling the movement.
- * When centering a hairspring on the bridge, what is the main objective?
- * When replacing a roller table on a balance staff, how far down on the staff should the roller fit before it is driven down to position?
- * When giving the dimensions of a mainspring, what three measurements are required?
- * What do we mean when we refer to the long and short parts of the balance?
- * What information should be given to order a balance staff?
- * When the watch is placed in a vertical position, if a heavy spot is on the bottom of the balance when the balance is at rest, how will the rate of the watch be affected above and below 220 degree amplitude in that position?
- * When the watch is placed in a vertical position, if a heavy spot is on the top of the balance when the balance is at rest, how will the rate of the watch be affected above and below 220 degree amplitude in that position?

Listed below are samples of some of the test questions used in the fifth written examination which was administered to the students on Thursday, August 3, 1967.

True-False Statements

- T F * The escapement is composed of the escape wheel, pallet and roller.
- T F * The ratio between the cannon pinion and hour wheel is 12 to 1.
- T F * If a watch is losing a considerable amount of time, it could be that a loose cannon pinion may be the trouble.
- T F * The exact location to dent the cannon pinion for tightening is always at the top edge of the cannon pinion.
- T F * A cannon pinion that rides up on the center post can be corrected by placing a dial washer on the watch.
- T F * A loose hour hand can be tightened with the use of an inverted cone punch.
- T F * A loose minute hand can be tightened with the use of a round face punch.
- T F * The most popular type of waterproof testing instruments employ either vacuum or pressure chambers.
- T F * The automatic watch is prevented from being wound too tightly by the use of a bridal which will slip in the barrel when the mainspring is wound fully.
- T F * The pilot and the hub are the two bearing surfaces on a stem.
- T F * To file a square on a stem a filing fixture is rarely used.
- T F * The two main types of balance staffs are: friction staffs and rivet staffs.
- T F * When replacing the roller on a shock-proof staff, special punches are needed to drive the roller down to position without damaging the roller.
- T F * The poising of the balance wheel should be accomplished before the roller table is replaced.
- T F * The balance pivot in its jewel should have .01 mm clearance.

Additional sample questions used in examination of August 3, 1967

- * What test is made to determine the space that exists between the face of the roller jewel and the fork slot corner at the instant drop lock takes place?
- * What test is taken to determine the proper position of the roller jewel in relation to the center of the staff?
- * If the receiving stone is moved outwards so that it will penetrate deeper into the periphery of the escape wheel, which of the following will occur? Check the two correct answers:
 1. Drop lock will be increased on the receiving stone.
 2. Corner clearance will be increased.
 3. Drop lock will be increased on the discharge stone.
 4. Drop lock will increase on both sides.
 5. Jewel pin shake will be increased on the discharge side of the escapement.
 6. Jewel pin shake will be increased on the receiving side of the escapement.
 7. Jewel pin shake will be increased on the receiving and discharge side of the escapement.
- * What is the term used when referring to a condition where the pallet lever is against the banking pin but the escape tooth cannot drop off the pallet stone?
- * How much corner clearance should be set in the escapement?
- * What kind of graver is used to turn a conical pivot?
- * Make a sketch of a rivet type of staff and name all its parts.
- * a) Checking the amount of lock when the pallet fork is moved to bring the guard pin into contact with the safety roller is termed _____.
b) How much lock should be present when this check is made?

CONFIDENTIAL RATING

of

Student: _____

| | Unable to rate | Excellent or Superior | Good | Average or Fair | Below Average | Unsatisfactory |
|---|----------------|-----------------------|------|-----------------|---------------|----------------|
| <u>Professional Conduct and Behavior</u> | | | | | | |
| <u>Writing Ability</u> | | | | | | |
| <u>Manual Dexterity</u> | | | | | | |
| <u>Productivity</u> | | | | | | |
| <u>Dependability</u> | | | | | | |
| <u>Punctuality</u> | | | | | | |
| <u>Industriousness</u> | | | | | | |
| <u>Maturity</u> | | | | | | |
| <u>Cooperation and Ability to Get Along With Others</u> | | | | | | |
| <u>Loyalty</u> | | | | | | |
| <u>Knowledge of Subject Matter</u> | | | | | | |
| <u>Speaking Ability</u> | | | | | | |
| <u>Scholarship (letter grade)</u> | | | | | | |
| <u>Organizational Ability</u> | | | | | | |
| <u>Health</u> | | | | | | |
| <u>Social Qualities</u> | | | | | | |
| <u>Leadership Abilities</u> | | | | | | |
| <u>Appearance & Neatness</u> | | | | | | |

What is your evaluation of this candidate in terms of continuing him on the program?

Other comments: _____

Name of Evaluator: _____ Date: _____

Title: _____

APPENDIX H
HOROLOGICAL SCHOOLS QUESTIONNAIRES

Listed below are the areas in which horological schools in the United States have indicated by way of a questionnaire their interest in participating in educational research work. A sample of the questionnaire is on page 249. In addition, the schools that wish to participate in each topic are listed.

1. Programmed instruction

- a. Chamberlain Vocational High, Washington, D.C.
- b. Lindsey Hopkins Education Center, Miami, Florida
- c. Michigan Rehabilitation Institute, Plainwell, Michigan
- d. Ohio Valley Watchmaking Institute, Cincinnati, Ohio
- e. Pennsylvania Rehabilitation Center, Johnstown, Pennsylvania
- f. Western Pennsylvania Horological Institute, Pittsburgh, Pa.
- g. Spencer School of Watchmaking, Spencer, North Carolina
- h. Paris Junior College, Paris, Texas
- i. Seattle Community College, Seattle, Washington
- j. Gem City College - School of Horology, Quincy, Illinois
- k. Spokane Community College, Spokane, Washington

2. Selection of Trainees

- a. Chamberlain Vocational High, Washington, D.C.
- b. Michigan Rehabilitation Institute, Plainwell, Michigan
- c. Oklahoma State Tech., Okmulgee, Oklahoma
- d. Paris Junior College, Paris, Texas
- e. Seattle Community College, Seattle, Washington
- f. Gem City College - School of Horology, Quincy, Illinois
- g. Houston Technical College, Houston, Texas

3. Useful Related Areas of Instruction for Horological Trainees

- a. Emily Griffith Opportunity School, Denver, Colorado
- b. Chamberlain Vocational High, Washington, D.C.
- c. Lindsey Hopkins Education Center, Miami, Fla.
- d. Ohio Valley Watchmaking Institute, Cincinnati, Ohio
- e. Pennsylvania Rehabilitation Center, Johnstown, Pa.
- f. Spencer School of Watchmaking, Spencer, North Carolina
- g. Paris Junior College, Paris, Texas
- h. Mary Karl Vocational Division, Daytona Beach Junior College, Daytona Beach, Fla.
- i. Western Pennsylvania Horological Institute, Pittsburgh, Pa.

4. Curriculum Construction for Various Levels of Competence

- a. Emily Griffith Opportunity School, Denver, Colorado
- b. Ohio Valley Watchmaking Institute, Cincinnati, Ohio
- c. Pennsylvania Rehabilitation Center, Johnstown, Pa.
- d. Spencer School of Watchmaking, Spencer, North Carolina
- e. South Carolina Trade School, West Columbia, South Carolina
- f. Woodrow Wilson Rehabilitation Center, Fishersville, Va.
- g. Mary Karl Vocational Division, Daytona Beach Junior College, Daytona Beach, Fla.
- h. Western Pennsylvania Horological Institute, Pittsburgh, Pa.

5. Visual Aids

- a. Alabama School of Trades, Gadsden, Ala.
- b. Emily Griffith Opportunity School, Denver, Colo.
- c. Chamberlain Vocational High, Washington, D.C.
- d. Lindsey Hopkins Education Center, Miami, Fla.
- e. Michigan Rehabilitation Institute, Plainwell, Michigan
- f. Ohio Valley Watchmaking Institute, Cincinnati, Ohio
- g. Oklahoma State Tech., Okmulgee, Oklahoma
- h. Pennsylvania Rehabilitation Center, Johnstown, Pa.
- i. South Carolina Trade School, West Columbia, South Carolina
- j. Paris Junior College, Paris, Texas
- k. Woodrow Wilson Rehabilitation Center, Fishersville, Va.
- l. Seattle Community College, Seattle, Washington
- m. Western Pennsylvania Horological Institute, Pittsburgh, Pa.
- n. Mary Karl Vocational Division, Daytona Beach Junior College,
Daytona Beach, Florida
- o. Houston Technical College, Houston, Texas
- p. Spokane Community College, Spokane, Washington

6. Post-institutional or Continuing Educational Programs

- a. Ohio Valley Watchmaking Institute, Cincinnati, Ohio
- b. Western Pennsylvania Horological Institute, Pittsburgh, Pa.

7. Training Environment Problems such as Contoured Bench Tops, etc.

- a. Michigan Rehabilitation Institute, Plainwell, Michigan
- b. Pennsylvania Rehabilitation Center, Johnstown, Pa.
- c. Woodrow Wilson Rehabilitation Center, Fishersville, Va.
- d. Mary Karl Vocational Division, Daytona Beach Junior College,
Daytona Beach, Florida
- e. Western Pennsylvania Horological Institute, Pittsburgh, Pa.

8. Criteria for Licensing and Certification Programs

- a. Alabama School of Trades, Gadsden, Ala.
- b. Chamberlain Vocational High, Washington, D.C.
- c. Lindsey Hopkins Education Center, Miami, Fla.
- d. South Carolina Trade School, West Columbia, South Carolina
- e. Seattle Community College, Seattle, Washington
- f. Mary Karl Vocational Division, Daytona Beach Junior College,
Daytona Beach, Florida
- g. Houston Technical College, Houston, Texas
- h. Western Pennsylvania Horological Institute, Pittsburgh, Pa.

Other areas of further research indicated by horological schools are as follows:

- a. Actual job requirements
- b. Standards for curricula
- c. A method of obtaining more students

Questionnaires were sent out to a total of 35 horological schools. ^{nineteen} Sixteen schools replied, out of which two schools indicated that they would not be interested in participating in research. The number of schools that indicated a desire to participate in a research effort in the various topics is listed below.

| <u>Topic</u> | <u>Number of Schools</u> |
|--|--------------------------|
| 1. Programmed Instruction | 11 |
| 2. Selection of Trainees | 7 |
| 3. Useful Related Areas of Instruction for Horological Trainees | 9 |
| 4. Curriculum Construction for Various Levels of Competence | 8 |
| 5. Visual Aids | 16 |
| 6. Post-institutional or Continuing Educational Programs | 2 |
| 7. Training Environment Problems such as Contoured Bench Tops, etc. | 5 |
| 8. Criteria for Licensing and Certification Programs .. | 8 |
| 9. Other | 3 |

Date _____

To: Hugh G. Wales, Project Supervisor
P.O. Box 2070, Station A
Champaign, Illinois 61820

From: Name _____ School _____
Address _____ City _____
State _____ Zip _____

I would like to see more study made of the following subjects:

1. _____ Programmed instruction
2. _____ Selection of trainees
3. _____ Useful related areas of instruction for horological trainees
4. _____ Curriculum construction for various levels of competence
5. _____ Visual aids
6. _____ Post-institutional or continuing educational programs
7. _____ Training environment problems such as contoured bench tops, etc.
8. _____ Criteria for licensing and certification programs
9. _____ Other _____

I would like to participate (either in planning the work or in actual research work) in the following subjects (any of those listed above or others in which you are interested):

Comments:

Your cooperation in returning this form on or before December 22 would expedite matters considerably.

ERIC REPORT RESUME

(TOP)

001

| | | | | | | | | |
|-----------------------------------|--|-------------------------|--|------|------|----------------------------|---|--|
| ERIC ACCESSION NO. | | RESUME DATE 01-31-68 | | P.A. | T.A. | IS DOCUMENT COPYRIGHTED? | YES <input type="checkbox"/> | NO <input checked="" type="checkbox"/> |
| CLEARINGHOUSE ACCESSION NUMBER | | | | | | ERIC REPRODUCTION RELEASE? | YES <input checked="" type="checkbox"/> | NO <input type="checkbox"/> |

100

101

102

103

TITLE

Research and Development Program for Training in Micro-precision and Watchmaking Skills

200

PERSONAL AUTHOR(S)

Smith, William O., Jr. and others

300

310

INSTITUTION (SOURCE)

University of Illinois, Urbana, Ill., Department of General Engineering

SOURCE CODE

REPORT/SERIES NO.

OTHER SOURCE

SOURCE CODE

320

330

OTHER REPORT NO.

OTHER SOURCE

SOURCE CODE

340

350

OTHER REPORT NO.

400

PUB'L. DATE

01-31-68

CONTRACT/GRANT NUMBER

OEG-4-6-062336-2081

500

501

PAGINATION, ETC.

250 p.

600

601

602

603

604

605

606

RETRIEVAL TERMS

607

IDENTIFIERS

800

801

802

803

804

805

806

807

808

809

ABSTRACT

This report presents the findings of a one-year study supported by a grant from the Department of Health, Education and Welfare under contract No. 6-2336 with the University of Illinois. The researchers, teachers and professional consultants have provided a substantial input of useful materials that will be helpful to a variety of micro-precision and watch technician personnel. Research and educational problems are viewed through the eyes and professional experience of the research oriented educator, the engineer, the production manager, the business executive, and the persons who are involved in the multitude of servicing activities that modern micro-precision technicians perform.

810

811

812

813

814

815

816

817

818

819

820

821

822

This research effort outlines the objectives in terms of the problems to be investigated and briefly describes the methods that were explored for solving them from the standpoint of the groups enumerated in the paragraph above. Insofar as this study is concerned with fundamental concepts of educational methods applicable to micro-precision technology, the various materials presented are focused upon the ways in which unique devices can be utilized by effective teachers not only in motivating students to enjoy their educational experiences but upon achieving the quality of performance that will be employable in the marketplace at an attractive rate of compensation.